



**VISHWARAJ SUGAR INDUSTRIES LIMITED**  
 CIN: U85110KA1995PLC017730

Our Company was incorporated as a public limited company under the Companies Act, 1956 in the name of Vishwanath Sugars Limited vide Certificate of Incorporation dated May 02, 1995 with the Registrar of Companies, Bangalore bearing Registration Number - 017730. Our Company was granted the Certificate of Commencement of Business by the RoC, Bangalore on December 21, 1999. The name of our Company was subsequently changed to Vishwanath Sugar and Steel Limited and a Fresh Certificate of Incorporation dated December 28, 2010 was issued by the Registrar of Companies, Bangalore. The name of our Company was further changed to Vishwaraj Sugar Industries Limited vide Certificate of Incorporation dated November 29, 2012 granted by the Registrar of Companies, Bangalore. For details of change in registered address of the Company, please refer the chapter "History and Certain Corporate Matters" on page no. 166 of this Red Herring Prospectus.

**Registered Office:** Bellad Bagewadi, Taluka Hukkeri, District Belgaum – 591 305  
**Tel No.:** +91 – 8333 – 251251; **Fax No.:** +91 – 8333 – 251323; **Email:** info@vsil.co.in; **Website:** www.vsil.co.in  
**Contact Person:** Mrs. Sneha Patil, Company Secretary and Compliance Officer.

**OUR PROMOTERS: MR UMESH KATTI, MR. RAMESH KATTI, MRS. SHEELA KATTI, MRS. JAYSHREE KATTI, MR. NIKHIL KATTI, MR. LAVA KATTI, MR. KUSH KATTI AND MRS. SNEHA NITHIN DEV**

**INITIAL PUBLIC OFFER OF UPTO 1,00,00,000 EQUITY SHARES OF FACE VALUE OF ₹ 10 EACH (THE "EQUITY SHARES") OF VISHWARAJ SUGAR INDUSTRIES LIMITED (OUR "COMPANY") FOR CASH AT A PRICE OF ₹ [●] PER EQUITY SHARE (INCLUDING A SHARE PREMIUM OF ₹ [●] PER EQUITY SHARE) AGGREGATING UP TO ₹ [●] LAKHS (THE "OFFER") COMPRISING OF A FRESH ISSUE OF UPTO 30,00,000 EQUITY SHARES BY OUR COMPANY AGGREGATING UP TO ₹ [●] LAKHS (THE "FRESH ISSUE") AND AN OFFER FOR SALE OF UPTO 70,00,000 EQUITY SHARES BY THE PERSONS LISTED IN ANNEXURE A (COLLECTIVELY REFERRED TO AS THE SELLING SHAREHOLDERS) AGGREGATING TO ₹ [●] LAKHS ("OFFER FOR SALE"). THE OFFER WOULD CONSTITUTE UPTO 26.63%, OF OUR POST-OFFER PAID-UP EQUITY SHARE CAPITAL.**

**THE FACE VALUE OF EQUITY SHARES IS ₹ 10 EACH AND THE OFFER PRICE IS [●] TIMES THE FACE OF THE EQUITY SHARES. THE PRICE BAND AND THE MINIMUM BID LOT WILL BE DECIDED BY OUR COMPANY AND THE SELLING SHAREHOLDERS IN CONSULTATION WITH THE BOOK RUNNING LEAD MANAGER AND WILL BE ADVERTISED IN, ALL EDITIONS OF THE ENGLISH NATIONAL NEWSPAPER BUSINESS STANDARD, ALL EDITIONS OF THE HINDI NATIONAL NEWSPAPER BUSINESS STANDARD AND BELGAUM EDITION OF KANNADA DAILY NEWSPAPER KANNADA PRABHA, (KANNADA BEING THE REGIONAL LANGUAGE OF KARNATAKA, WHEREOUR REGISTERED OFFICE IS LOCATED), EACH WITH WIDE CIRCULATION, AT LEAST TWO WORKING DAYS PRIOR TO THE BID/OFFER OPENING DATE AND SHALL BE MADE AVAILABLE TO BSE LIMITED ("BSE") AND NATIONAL STOCK EXCHANGE OF INDIA LIMITED ("NSE") FOR THE PURPOSE OF UPLOADING ON THEIR WEBSITES.**

In case of any revision in the Price Band, the Offer Period shall be extended for at least three additional Working Days after such revision of the Price Band, subject to the total Offer Period not exceeding 10 Working Days. Any revision in the Price Band, and the revised Offer Period, if applicable, shall be widely disseminated by notification to the Stock Exchanges by issuing a press release, and also by indicating the change on the websites of the Book Running Lead Manager and at the terminals of the other members of the Syndicate and by intimation to Self Certified Syndicate Banks ("SCSBs"), the Sponsor Bank and the Designated Intermediaries.

In terms of Rule 19(2)(b)(i) of the Securities Contracts (Regulation) Rules, 1957, as amended ("SCRR"), this is an Offer for at least 25% of the Post-Offer paid-up equity share capital of our Company. The Offer is being made through the Book Building Process in accordance with Regulation 26 (1) of the SEBI ICDR Regulations, 2009 as amended (the "SEBI ICDR Regulations"), where in not more than 10% of the Offer shall be allocated on a proportionate basis to Qualified Institutional Buyers ("QIBs") ("QIB Portion"), 5% of the QIB Portion shall be available for allocation on a proportionate basis to Mutual Funds only, and the remainder of the QIB Portion shall be available for allocation on a proportionate basis to all QIB Bidders, including Mutual Funds, subject to valid Bids being received at or above the Offer Price. Further, not less than 40% of the Offer shall be available for allocation on a proportionate basis to Non-Institutional Bidders and not less than 50% of the Offer shall be available for allocation to Retail Individual Bidders in accordance with the SEBI ICDR Regulations, subject to valid Bids being received at or above the Offer Price. Under-subscription, if any, in any category, except the QIB Portion, would be met with spill-over from any other category or categories, as applicable, on a proportionate basis, subject to applicable law. All potential investors are required to mandatorily use the Application Supported by Blocked Amount ("ASBA") process including through UPI mode (as applicable) by providing details of the irrespective bank accounts and/ or UPI IDs, in case of RIIs, if applicable, which will be blocked by the Self Certified Syndicate Banks ("SCSBs"). **Specific attention of investors is invited to the chapter titled "Offer Procedure" on page no. 330 of this Red Herring Prospectus.**

**RISK IN RELATION TO THE FIRST OFFER**

This being the first public offer of our Company, there has been no formal market for the Equity Shares of our Company. The face value of the Equity Shares is ₹ 10 per Equity Share and the Offer price is [●] times the face value. The Offer Price, as determined and justified by our Company in consultation with the Selling Shareholders and the BRLM, on the basis of assessment of market demand for the Equity Shares by way of the Book Building Process, as stated under the section entitled "Basis for the Offer Price" on page no. 108 of this Red Herring Prospectus should not be taken to be indicative of the market price of the Equity Shares after the Equity Shares are listed. No assurance can be given regarding an active and/or sustained trading in the Equity Shares nor regarding the price at which the Equity Shares will be traded after listing.

**GENERAL RISKS**

Investment in equity and equity related securities involve a degree of risk and investors should not invest any funds in this Offer unless they can afford to take the risk of losing their investment. Investors are advised to read the risk factors carefully before taking an investment decision in this Offer. For taking an investment decision investors must rely on their own examination of our Company and the Offer, including the risks involved. The equity shares offered in the Offer have not been recommended or approved by SEBI nor does SEBI guarantee the accuracy or adequacy of this Red Herring Prospectus. **Specific attention of the investors is invited to the section entitled "Risk Factors" on page no. 17 of this Red Herring Prospectus.**

**ISSUER'S AND SELLING SHAREHOLDERS' ABSOLUTE RESPONSIBILITY**

Our Company, having made all reasonable inquiries, accepts responsibility for and confirms that this Red Herring Prospectus contains all information with regard to our Company and the Offer, which is material in the context of the Offer, that the information contained in this Red Herring Prospectus is true and correct in all material aspects and is not misleading in any material respect, that the opinions and intentions expressed herein are honestly held and that there are no other facts, the omission of which makes this Red Herring Prospectus as a whole or any of such information or the expression of any such opinions or intentions misleading in any material respect. Each of the Selling Shareholders severally and not jointly accept responsibility only for the statements made by them in this Red Herring Prospectus and confirm that this Red Herring Prospectus contains all information about themselves as selling shareholders and the Equity Shares offered by each of them in the Offer, and that such statements are true and correct in all material respects and are not misleading in any material respect.

**LISTING**

The Equity Shares offered through the Red Herring Prospectus are proposed to be listed on the BSE and the NSE. Our Company has received 'in-principle' approval from the BSE and the NSE for the listing of the Equity Shares pursuant to letters dated January 12, 2018 and January 10, 2018, respectively. For the purposes of the Offer, BSE Limited will be the Designated Stock Exchange. A copy of the Red Herring Prospectus and the Prospectus shall be delivered for registration to the RoC, Bangalore in accordance with Section 26(4) of the Companies Act, 2013. For details of the material contracts and documents available for inspection from the date of the Red Herring Prospectus upto the Bid/Offer Closing Date, please see the section titled "Material Contracts and Documents for Inspection" on page no. 363 of this Red Herring Prospectus.

**BOOK RUNNING LEAD MANAGER**

**REGISTRAR TO THE OFFER**



**ARYAMAN FINANCIAL SERVICES LIMITED**  
 60, Khatau Building, Ground Floor,  
 Alkesh Dinesh Modi Marg, Fort, Mumbai – 400 001.  
 Tel No.: +91 – 22 – 6216 6999  
 Fax No.: +91 – 22 – 2263 0434  
 Email: ipo@afsl.co.in  
 Investor Grievance Email: feedback@afsl.co.in  
 Website: www.afsl.co.in  
 SEBI Registration No.: INM000011344  
 Contact Person: Mr. Pranav Nagar



**BIGSHARE SERVICES PRIVATE LIMITED**  
 1<sup>st</sup> Floor, Bharat Tin Works Building, Opp. Vasant Oasis,  
 Makwana Road, Marol, Andheri (E), Mumbai – 400 059.  
 Tel: +91 – 22 – 6263 8200  
 Fax: +91 – 22 – 6263 8299  
 Email: ipo@bigshareonline.com  
 Investor Grievance Email: investor@bigshareonline.com  
 Website: www.bigshareonline.com  
 SEBI Registration No.: INR000001385  
 Contact Person: Mr. Ashish Bhope

**BID / OFFER PROGRAMME**

**BID / OFFER OPENS ON: SEPTEMBER 30, 2019**

**BID / OFFER CLOSES ON: OCTOBER 04, 2019**

## TABLE OF CONTENTS

<b>SECTION I – GENERAL</b> .....	<b>1</b>
DEFINITIONS AND ABBREVIATIONS .....	1
CERTAIN CONVENTIONS AND PRESENTATION OF FINANCIAL .....	13
FORWARD-LOOKING STATEMENTS .....	15
<b>SECTION II - RISK FACTORS</b> .....	<b>17</b>
<b>SECTION III – INTRODUCTION</b> .....	<b>46</b>
SUMMARY OF OUR INDUSTRY .....	46
SUMMARY OF OUR BUSINESS.....	50
SUMMARY OF FINANCIAL INFORMATION.....	55
THE OFFER .....	59
GENERAL INFORMATION .....	61
CAPITAL STRUCTURE .....	69
<b>SECTION IV – PARTICULARS OF THE OFFER</b> .....	<b>102</b>
OBJECTS OF THE OFFER.....	102
BASIS FOR OFFER PRICE.....	108
BASIC TERMS OF THE OFFER .....	111
STATEMENT OF TAX BENEFITS .....	113
<b>SECTION V: ABOUT OUR COMPANY</b> .....	<b>115</b>
INDUSTRY OVERVIEW .....	115
OUR BUSINESS .....	130
KEY REGULATIONS AND POLICIES .....	156
HISTORY AND CERTAIN CORPORATE MATTERS .....	166
OUR MANAGEMENT .....	171
OUR PROMOTERS AND PROMOTER GROUP.....	188
OUR GROUP COMPANIES.....	197
DIVIDEND POLICY.....	201
<b>SECTION VI – FINANCIAL INFORMATION</b> .....	<b>202</b>
FINANCIAL STATEMENTS .....	202
OTHER FINANCIAL INFORMATION.....	250
CAPITALISATION STATEMENT .....	251
MANAGEMENT DISCUSSION AND ANALYSIS OF FINANCIAL CONDITION AND RESULTS OF OPERATION.....	252
FINANCIAL INDEBTEDNESS .....	273
<b>SECTION VII – LEGAL AND OTHER REGULATORY INFORMATION</b> .....	<b>277</b>
OUTSTANDING LITIGATIONS AND MATERIAL DEVELOPMENTS .....	277
GOVERNMENT & OTHER KEY APPROVALS .....	300
<b>SECTION VIII - OTHER REGULATORY AND STATUTORY DISCLOSURES</b> .....	<b>310</b>
<b>SECTION IX – OFFER RELATED INFORMATION</b> .....	<b>323</b>
TERMS OF THE OFFER .....	323
OFFER STRUCTURE.....	328
OFFER PROCEDURE .....	330
RESTRICTIONS ON FOREIGN OWNERSHIP OF INDIAN SECURITIES.....	346
<b>SECTION X - MAIN PROVISIONS OF ARTICLES OF ASSOCIATION</b> .....	<b>347</b>
<b>SECTION XI – OTHER INFORMATION</b> .....	<b>363</b>
MATERIAL CONTRACTS AND DOCUMENTS FOR INSPECTION .....	363
DECLARATION .....	365
ANNEXURE A – LIST OF SELLING SHAREHOLDERS .....	367

## SECTION I – GENERAL

### DEFINITIONS AND ABBREVIATIONS

This Red Herring Prospectus uses certain definitions and abbreviations which, unless the context otherwise indicates or implies, shall have the meaning as provided below. References to any legislation, act, regulation, rule, guideline or policy shall be to such legislation, act, regulation, rule, guideline or policy, as amended, supplemented or re-enacted from time to time.

The words and expressions used in this Red Herring Prospectus but not defined herein, shall have, to the extent applicable, the meaning ascribed to such terms under the Companies Act, the SEBI ICDR Regulations, the SCRA, the Depositories Act or the rules and regulations made there under. If there is any inconsistency between the definitions given below and the definitions contained in the General Information Document (defined hereinafter), the following definitions shall prevail.

#### General Terms

Term	Description
Vishwaraj Sugar Industries Ltd. / VSIL / Our Company / the Company / the Issuer / We / Us / Our	Vishwaraj Sugar Industries Limited, a public limited company incorporated under the provisions of the Companies Act, 1956 having its registered office at Bellad Bagewadi, Taluka Hukkeri, Belgaum – 591 305, Karnataka, India.

#### Company related Terms

Term	Description
Acquirer Promoters	Our Promoters, namely, Mr. Umesh Katti and Mr. Nikhil Katti, who offered to acquire shares in the Exit Offers.
Articles, Articles of Association, AOA	The Articles of Association of our Company, as amended.
Audit Committee	The committee of the Board of Directors as described in the chapter “ <i>Our Management</i> ” on page no. 171 of this Red Herring Prospectus re-constituted on December 18, 2017 in accordance with Section 177 of the Companies Act, 2013 and SEBI Listing Regulations.
Auditor / Statutory Auditor	The Statutory Auditors of our Company, being M/s. Gojanur & Co., Chartered Accountants having their office at No. 2 & 13, Basava Sadana Complex, Nehru Road, Shivamogga – 577 201, Karnataka
Board / Board of Directors / our Board	The Board of Directors of our Company, as duly constituted from time to time including any committees thereof.
Chief Financial Officer / CFO	Mr. Sheshagiri Kulkarni
Company Secretary and Compliance Officer / CS	Ms. Sneha Patil
CSR Committee	The Corporate Social Responsibility committee of our Board, as described in the chapter “ <i>Our Management</i> ” on page no. 171 of this Red Herring Prospectus.
Director(s)	Unless the context requires otherwise, the director(s) of our Company
Equity Shares	Equity Shares of our Company of face value of ₹ 10 each unless otherwise specified in the context thereof.
Equity Shareholders	Persons holding Equity Share of our Company.
Group Companies	<ul style="list-style-type: none"> <li>• U R Agrofresh Private Limited</li> <li>• UK27 Hospitality Services Private Limited</li> <li>• Vishwaraj Infrastructure Private Limited</li> </ul> For details please refer page no. 197 of this Red Herring Prospectus.
Key Management Personnel / KMP	The personnel listed as Key Managerial Personnel as described in the chapter “ <i>Our Management</i> ” on page no. 171 of this Red Herring Prospectus.
Memorandum of Association / MOA	The Memorandum of Association of our Company.

Term	Description
Nomination and Remuneration Committee	The committee of the Board of Directors re-constituted on December 18, 2017, as our Company's Nomination and Remuneration Committee in accordance with Section 178 of the Companies Act, 2013
Promoters	<ul style="list-style-type: none"> <li>• Mr. Umesh Katti</li> <li>• Mr. Ramesh Katti</li> <li>• Mrs. Sheela Katti</li> <li>• Mrs. Jayashree Katti</li> <li>• Mr. Nikhil Katti</li> <li>• Mr. Lava Katti</li> <li>• Mr. Kush Katti</li> <li>• Mrs. Sneha Nithin Dev</li> </ul>
Promoter Group	The persons and entities constituting our promoter group pursuant to Regulation 2(1) (zb) of the SEBI ICDR Regulations.
Restated Financials / Restated Financial Information	The financial information of the Company which comprises of the restated statement of assets and liabilities as at March 31, 2019, 2018, 2017, 2016 and 2015, the restated statement of profit and loss and the restated cash flow statement for the years ended March 31, 2019, 2018, 2017, 2016 and 2015, and the related notes, schedules and annexures thereto included in this Red Herring Prospectus, which have been prepared in accordance with Ind AS read with Section 133 of the Companies Act, 2013, and restated in accordance with the SEBI ICDR Regulations.
Registered Office	Bellad Bagewadi, Taluka: Hukkeri District Belgaum, Karnataka – 591305, India.
Registrar of Companies / RoC	Registrar of Companies, Karnataka at Bangalore
Selling Shareholders	Persons who have offered their shares as part of the Offer for Sale in this Offer, listed in "Annexure A" on page no. 367 of this Red Herring Prospectus.
Stakeholders' Relationship Committee	The committee of the Board of Directors re-constituted on December 18, 2017 as our Company's Stakeholders' Relationship Committee.

#### Offer Related Terms

Term	Description
Acknowledgement Slip	The slip or document issued by the Designated Intermediary to a Bidder as proof of registration of the ASBA Form
Allot / Allotment / Allotted	The allotment of the Equity Shares pursuant to the Fresh Issue and transfer of the respective portion of the Equity Shares offered by the Selling Shareholders pursuant to the Offer for Sale to the successful Bidders.
Allotment Advice	The note or advice or intimation of Allotment of the Equity Shares sent to the Bidders who have been or are to be allotted the Equity Shares after the Basis of Allotment has been approved by the Designated Stock Exchange.
Allottee(s)	A successful Bidder to whom Allotment is made.
Application Supported by Blocked Amount / ASBA	An application, whether physical or electronic, used compulsorily by all the Bidders (except Anchor Investors) authorizing the SCSBs to block the Bid Amount in their specified bank account maintained with such SCSB and will include amounts blocked by RIIs using the UPI mechanism.
ASBA Account	A bank account maintained with an SCSB and specified in the Bid-cum-Application Form submitted by a Bidder, which will be blocked by such SCSB or the account of the RII Bidder blocked upon acceptance of UPI Mandate Request by RIIs using the UPI mechanism, to the extent of the Bid Amount specified by the Bidder.
Banker(s) to the Company	Such banks which are disclosed as Bankers to our Company in the chapter titled "General Information" on page no. 61 of this Red Herring Prospectus.
Banker(s) to the Offer / Escrow Collection Bank(s) / Public Offer Bank	The banks which are Clearing Members and registered with SEBI as Banker to an Offer with whom the Escrow Agreement is entered and in this case being ICICI Bank Limited and includes the Escrow Bank(s), Refund Bank(s), Sponsor Bank, and Public Offer Account Bank(s), as the case may be.
Basis of Allotment	Basis on which the Equity Shares will be Allotted to successful Bidders under the Offer and which is described in the chapter "Offer Procedure" on page no. 330 of this Red Herring Prospectus.

Term	Description
Bid / ASBA Bid	An indication to make an offer during the Bid / Offer Period by a Bidder pursuant to submission of the Bid-cum-Application Form to subscribe to or purchase the Equity Shares of our Company at a price within the Price Band, including all revisions and modifications thereto as permitted under the SEBI ICDR Regulations, 2018 and in terms of this Red Herring Prospectus and the Bid cum Application Form.
Bid Amount	The highest value of optional Bids indicated in the Bid-cum-Application Form and payable by the Bidder or blocked in the ASBA Account on submission of a Bid in the Offer.
Bid cum Application Form	The form, whether physical or electronic, used by a Bidder, to make a Bid and which will be considered as a Bid for Allotment in terms of this Red Herring Prospectus and the Prospectus.
Bid Lot	[●] Equity Shares.
Bid Price	The prices indicated against each optional Bid in the Bid cum Application Form.
Bid / Offer Closing Date	The date after which the Designated Intermediaries will not accept any Bids, and which shall be notified in all editions of Business Standard (a widely circulated English national daily newspaper), all editions of Business Standard (a widely circulated Hindi national daily newspaper) and the regional edition of Kannada Prabha (a widely circulated Kannada newspaper, Kannada being the regional language of the State of Karnataka, where the Registered Office of our Company is situated) and in case of any revision, the extended Bid Closing Date also to be notified on the website and terminals of the Syndicate and SCSBs, as required under the SEBI ICDR Regulations, 2018 and also intimated to SCSBs, the Sponsor Bank and the Designated Intermediaries.
Bid / Offer Opening Date	The date on which the Designated Intermediaries shall start accepting Bids, and which shall be notified in all editions of Business Standard (a widely circulated English national daily newspaper), all editions of Business Standard (a widely circulated Hindi national daily newspaper) and the regional edition of Kannada Prabha (a widely circulated Kannada newspaper, Kannada being the regional language of the State of Karnataka, where the Registered Office of our Company is situated).
Bid / Offer Period	The period between the Bid / Offer Opening Date and the Bid / Offer Closing Date (inclusive of both days) during which prospective Bidders can submit their Bids, inclusive of any revision thereof in accordance with the SEBI ICDR Regulations 2018 and the terms of this Red Herring Prospectus.. Provided however that the Bidding shall be kept open for a minimum of three Working Days for all categories of Bidders.
Bidder	Any prospective investor who makes a Bid pursuant to the terms of this Red Herring Prospectus, and the Bid-cum-Application Form unless stated or implied otherwise
Bidding	The process of making a Bid.
Bidding Centre	Centres at which Designated Intermediaries shall accept the ASBA Forms, i.e., Designated Branches for SCSBs, Specified Locations for Syndicate, Broker Centres for Registered Brokers, Designated RTA Locations for CRTAs and Designated CDP Locations for CDPs.
Book Building Process / Method	The book building route as provided under Schedule XIII of the SEBI ICDR Regulations, 2018 in terms of which the Offer is being made.
Book Running Lead Manager / BRLM	Aryaman Financial Services Limited.
Broker Centres	Broker centres notified by the Stock Exchanges, where Bidders can submit the Bid cum Application Forms to a Registered Broker. The details of such Broker Centres, along with the names and contact details of the Registered Brokers are available on the websites of the Stock Exchanges i.e. <a href="http://www.bseindia.com">www.bseindia.com</a> and <a href="http://www.nseindia.com">www.nseindia.com</a> .
Business Day	Monday to Friday (except public holidays)
CAN / Confirmation of Allocation Note	The note or advice or intimation sent to each successful Bidder indicating the Equity Shares which will be Allotted, after approval of Basis of Allotment by the Designated Stock Exchange.
Cap Price	The higher end of the Price Band and any revisions thereof, above which the Offer Price will not be finalized and above which no Bids will be accepted.
Client ID	Client identification number maintained with one of the Depositories in relation to demat account.
Collecting Depository Participant(s) / CDP(s)	A depository participant as defined under the Depositories Act, 1996, registered with SEBI and who is eligible to procure Bids at the Designated CDP Locations in terms of



Term	Description
	circular No. CIR/CFD/POLICYCELL/11/2015 dated November 10, 2015 and the UPI Circulars issued by SEBI
Collecting Registrar and Share Transfer Agents / CRTAs	Registrar and Share Transfer Agents registered with SEBI and eligible to procure Applications at the Designated RTA Locations in terms of circular No. CIR/CFD/POLICYCELL/11/2015 dated November 10, 2015 issued by SEBI, and the UPI Circulars
Controlling Branches	Such Branches of the SCSBs which co-ordinate Bids by the Bidders with the BRLM, Registrar to the Offer and the Stock Exchanges and a list of which is available at <a href="http://www.sebi.gov.in">http://www.sebi.gov.in</a> .
Cut-Off Price	Offer Price, as finalized by our Company and the Selling Shareholders in consultation with the BRLM, which shall be any price within the Price Band. Only Retail Individual Bidders are entitled to Bid at the Cut-off Price. QIBs and Non-Institutional Bidders are not entitled to Bid at the Cut-off Price.
Demographic Details	The details of the Bidders including the Bidders' address, names of the Bidders' father/husband, investor status, occupation and bank account details and UPI ID wherever applicable.
Depositories	A depository registered with SEBI under the SEBI (Depositories and Participant) Regulations, 1996 i.e. CDSL and NSDL
Depositories Act	The Depositories Act, 1996, as amended from time to time.
Depository Participant / DP	A depository participant registered with the SEBI under the Depositories Act.
Designated Branches	Such branches of the SCSBs, which shall collect the Bid cum Application Form from ASBA Bidders, a list of which is available on the website of SEBI at <a href="https://www.sebi.gov.in/sebiweb/other/OtherAction.do?doRecognised=yes">https://www.sebi.gov.in/sebiweb/other/OtherAction.do?doRecognised=yes</a> or at such other website as may be prescribed by SEBI from, time to time.
Designated Locations	Such locations of the CDPs where Bidders can submit the Bid-cum-Application Forms. The details of such Designated CDP Locations, along with names and contact details of the Collecting Depository Participants eligible to accept Bid-cum-Application Forms are available on the respective websites of the Stock Exchanges (at <a href="http://www.bseindia.com">www.bseindia.com</a> and <a href="http://www.nseindia.com">www.nseindia.com</a> , respectively) as updated from time to time.
Designated Date	The date on which funds are transferred from the Escrow Account and the amounts blocked by the SCSBs are transferred from the ASBA Accounts, as the case may be, to the Public Offer Account or the Refund Account, as appropriate, in terms of this Red Herring Prospectus and the Prospectus, and the aforesaid transfer and instructions shall be issued only after finalization of the Basis of Allotment in consultation with the Designated Stock Exchange.
Designated Intermediaries / Collecting Agent	In relation to ASBA Forms submitted by RIIs by authorising an SCSB to block the Bid Amount in the ASBA Account, Designated Intermediaries shall mean SCSBs.  In relation to ASBA Forms submitted by RIIs where the Bid Amount will be blocked upon acceptance of UPI Mandate Request by such RII using the UPI Mechanism, Designated Intermediaries shall mean Syndicate, Sub-Syndicate / agents, Registered Brokers, CDPs and CRTAs.  In relation to ASBA Forms submitted by QIBs and NIBs, Designated Intermediaries shall mean Syndicate, Sub-Syndicate / agents, SCSBs, Registered Brokers, the CDPs and CRTAs
Designated Locations	Such locations of the CRTAs where Bidders can submit the Bid-cum-Application Forms to CRTAs. The details of such Designated RTA Locations, along with names and contact details of the CRTAs eligible to accept Bid-cum-Application Forms are available on the websites of the Stock Exchanges ( <a href="http://www.bseindia.com">www.bseindia.com</a> and <a href="http://www.nseindia.com">www.nseindia.com</a> ) as updated from time to time.
Designated Stock Exchange	BSE Limited
Draft Red Herring Prospectus / DRHP	The Draft Red Herring Prospectus dated December 20, 2017 prepared and issued by our Company in accordance with the SEBI ICDR Regulations which does not contain complete particulars of the price at which the Equity Shares will be Allotted and the size of the Offer.

Term	Description
Eligible NRI(s)	NRI(s) from such a jurisdiction outside India where it is not unlawful to make an offer or invitation under this Offer and in relation to whom this Red Herring Prospectus constitutes an invitation to subscribe to or purchase the Equity Shares.
Eligible QFIs	Qualified Foreign Investors from such jurisdictions outside India where it is not unlawful to make an invitation under the offer and in relation to whom this Red Herring Prospectus constitutes an invitation to subscribe to or purchase the Equity Shares issued thereby, and who have opened dematerialized accounts with SEBI registered qualified depository participants, and are deemed as FPIs under the SEBI FPI Regulations
Escrow Account(s)	Account opened with the Escrow Collection Bank(s)
Escrow and Sponsor Bank Agreement	The Agreement dated September 11, 2019 entered into amongst the Company, the BRLM, the Selling Shareholders, the Registrar to the Offer and the Banker to the Offer to receive monies from the Bidders through the SCSBs Bank Account on the Designated Date in the Public Offer Account.
First Bidder	Bidder whose name appears first in the Bid cum Application Form in case of a joint bid and whose name shall also appear as the first holder of the beneficiary account held in joint names or any revisions thereof.
Floor Price	The lower end of the Price Band, and any revisions thereof, below which the Offer Price will not be finalized and below which no Bids will be accepted and which shall not be less than the face value of the Equity Shares, in this case being ₹ [●]
Foreign Portfolio Investor / FPIs	Foreign Portfolio Investor as defined under the SEBI (Foreign Portfolio Investors) Regulations, 2014.
Fresh Issue	Fresh Issue of upto 30,00,000 Equity Shares aggregating up to ₹ [●] lakhs by our Company.
General Information Document / GID	The General Information Document for investing in public issues prepared and issued in accordance with the circular (CIR/CFD/DIL/12/2013) dated October 23, 2013, notified by SEBI and certain other amendments to applicable laws and updated pursuant to the circular (CIR/CFD/POLICYCELL/11/2015) dated November 10, 2015, the circular (CIR/CFD/DIL/1/2016) dated January 1, 2016 and (SEBI/HO/CFD/DIL/CIR/P/2016/26) dated January 21, 2016 and circular (SEBI/HO/CFD/DIL2/CIR/P/2018/138) dated November 1, 2018 notified by SEBI and included in the chapter “Offer Procedure” on page no. 330 of this Red Herring Prospectus.
Listing Agreement	The listing agreement(s) to be entered into by our Company with the Stock Exchanges
Maximum RII Allottees	Maximum number of RIIs who can be allotted the minimum Bid Lot. This is computed by dividing the total number of Equity Shares available for Allotment to RIIs by the minimum Bid Lot.
Mutual Funds	Mutual funds registered with SEBI under the Securities and Exchange Board of India (Mutual Funds) Regulations, 1996.
Mutual Fund Portion	Upto 50,000 Equity Shares or 5% of the Net QIB Portion, available for allocation to Mutual Funds only, on a proportionate basis, subject to valid Bids being received at or above the Offer Price.
Net Proceeds / Net Offer Proceeds	Proceeds of the Fresh Issue less our Company’s share of the Offer related expenses. For further details regarding the use of the Net Proceeds and the Offer expenses, see “Objects of the Offer” beginning on page no. 102 of this Red Herring Prospectus.
Non-Institutional Bidders	All Bidders that are not Qualified Institutional Buyers or Retail Individual Bidders and who have Bid for Equity Shares for a cumulative amount more than ₹ 200,000 (but not including NRIs other than Eligible NRIs, QFIs other than Eligible QFIs).
Non-Institutional Portion / Non-Institutional Category	The portion of the Offer being not less than 40% of the Offer consisting of 40,00,000 Equity Shares, available for allocation on a proportionate basis to Non- Institutional Bidders subject to valid bids received at or above the Offer Price.
Non-Resident	Person resident outside India, as defined under FEMA and includes a non-resident Indian, FIIs, FVCIs and FPIs
Non - Resident Indian	An individual resident outside India who is a citizen of India or is an ‘Overseas Citizen of India’ cardholder within the meaning of section 7(A) of the Citizenship Act, 1955, and shall have the meaning ascribed to such term in the FEMA Regulations
Offer	The Public Offer of upto 1,00,00,000 Equity Shares of face value of ₹ 10 each for cash at a price of ₹ [●] each, aggregating up to ₹ [●] lakhs comprising the Fresh Issue and the Offer for Sale.
Offer Agreement	The agreement dated December 18, 2017 entered into between our Company, the Selling

Term	Description
	Shareholders and the BRLM, pursuant to which certain arrangements are agreed to in relation to the Offer.
Offer Expenses	Expenses in connection with the Offer (including the listing fees).
Offer for Sale / OFS	The offer for sale of upto 70,00,000 Equity Shares by the Selling Shareholders at the Offer Price aggregating up to ₹ [●] lakhs in terms of this Red Herring Prospectus.
Offer Price	The price as determined by our Company and the Selling Shareholders in consultation with the BRLM on the Pricing Date, at which the Equity Shares will be issued and Allotted / transferred in terms of this Red Herring Prospectus.
Offer Proceeds	The proceeds of this Offer available to our Company and the Selling Shareholders.
Price Band	<p>Price band between the Floor Price and Cap Price (both included), including any revisions thereof.</p> <p>The Price Band and the minimum Bid lot size for the Offer will be decided by our Company and the Selling Shareholders in consultation with the BRLM and advertised in all editions of Business Standard (a widely circulated English national daily newspaper), all editions of Business Standard (a widely circulated Hindi national daily newspaper) and the regional edition of Kannada Prabha (a widely circulated Kannada newspaper, Kannada being the regional language of the State of Karnataka, where the Registered Office of our Company is situated) at least two Working Days prior to the Bid/Offer Opening Date, with the relevant financial ratios calculated at the Floor Price and at the Cap Price and shall be made available to the Stock Exchanges for the purpose of uploading on their websites.</p>
Pricing Date	The date on which the Offer Price is finalized by our Company and the Selling Shareholders, in consultation with the BRLM.
Prospectus	The prospectus of our Company to be filed with the RoC for this Offer after the Pricing Date, within the provisions of Section 26 of the Companies Act, 2013 and the SEBI ICDR Regulations containing, inter alia, the Offer Price that is determined at the end of the Book Building Process, the size of the Offer and certain other information.
Public Offer Account	A bank account opened in accordance with the Companies Act, 2013 to receive monies from the Escrow Account and from the ASBA Accounts on the Designated Date.
QIBs / Qualified Institutional Buyers	Qualified Institutional Buyers as defined under Regulation 2(1)(zd) of the SEBI ICDR Regulations.
QIB Portion / QIB Category	The portion of the Offer being not more than 10% of the Offer or 10,00,000 Equity Shares which shall be available for allocation to QIBs on a proportionate basis subject to valid Bids being received at or above the Offer Price.
Red Herring Prospectus / RHP	<p>This Red Herring Prospectus dated September 16, 2019 to be issued in accordance with Section 32 of the Companies Act, 2013 and the SEBI ICDR Regulations, which will not have complete particulars of the price at which the Equity Shares shall be offered and the size of the Offer.</p> <p>The Red Herring Prospectus will be registered with the RoC at least three Working Days before the Bid/Offer Opening Date and will become the Prospectus upon filing with the RoC after the Pricing Date.</p>
Refund Account(s)	The account(s) opened by our Company, from which refunds of the whole or part of the Bid Amount to the Bidders shall be made.
Refund Bank(s)	Bank which is a clearing member and registered with SEBI as a Banker to an Offer and with whom the Refund Account will be opened, in this case being, ICICI Bank Limited
Registrar Agreement	The agreement dated November 27, 2017, entered between our Company, the Selling Shareholders and the Registrar to the Offer, in relation to the responsibilities and obligations of the Registrar to the Offer pertaining to the Offer.
Registered Brokers	Stock brokers registered with SEBI under the Securities and Exchange Board of India (Stock Brokers and Sub Brokers) Regulations, 1992 and the stock exchanges having nationwide terminals, other than the Members of the Syndicate eligible to procure Bids in terms of Circular No. CIR/CFD/14/2012 dated October 04, 2012 issued by SEBI, and the UPI Circulars.
Registrar / Registrar to the Offer	Bigshare Services Private Limited
Retail Individual	Individual investors (including HUFs, in the name of Karta and Eligible NRIs) who Bid



<b>Term</b>	<b>Description</b>
Investors / RIIs	for the Equity Shares of a value of not more than ₹2,00,000 in any of the Bidding options in the Offer
Retail Portion / Retail Category	The portion of the Offer being not less than 50% of the Offer, consisting of 50,00,000 Equity Shares, available for allocation on a proportionate basis to Retail Individual Bidders in accordance with the SEBI ICDR Regulations subject to valid Bids being received at or above the Offer Price.
Revision Form	The form used by the Bidders to modify the quantity of Equity Shares or the Bid Amount in any of their Bid-cum-Application Forms or any previous Revision Form(s).  QIB Bidders and Non-Institutional Investors are not allowed to withdraw or lower their Bids (in terms of quantity of Equity Shares or the Bid Amount) at any stage. Retail Individual Bidders can revise their Bids during the Bid / Offer Period and withdraw their Bids until the Bid / Offer Closing Date.
Self Certified Syndicate Bank(s) / SCSBs	The banks registered with SEBI, which offer services, (i) in relation to ASBA, where the Bid Amount will be blocked by authorising an SCSB, a list of which is available on the website of SEBI at <a href="http://www.sebi.gov.in/sebiweb/other/OtherAction.do?doRecognisedFpi=yes&amp;intmId=34">www.sebi.gov.in/sebiweb/other/OtherAction.do?doRecognisedFpi=yes&amp;intmId=34</a> and updated from time to time and at such other websites as may be prescribed by SEBI from time to time, (ii) in relation to RIIs using the UPI Mechanism, a list of which is available on the website of SEBI at <a href="https://sebi.gov.in/sebiweb/other/OtherAction.do?doRecognisedFpi=yes&amp;intmId=40">https://sebi.gov.in/sebiweb/other/OtherAction.do?doRecognisedFpi=yes&amp;intmId=40</a> or such other website as updated from time to time
Share Escrow Agent	Share Escrow agent appointed pursuant to the Share Escrow Agreement, being Bigshare Services Private Limited
Share Escrow Agreement	Agreement dated August 26, 2019 entered into between the Selling Shareholder, our Company, the Escrow Agent and the BRLM in connection with the transfer of Equity Shares under the Offer for Sale by the Selling Shareholder and credit of such Equity Shares to the demat account of the Allottees
Specified Locations	Bidding centres where the Syndicate shall accept Bid cum Application Forms from the Bidders.
Sponsor Bank	A Banker to the Offer which is registered with SEBI and is eligible to act as a Sponsor Bank in a public issue in terms of applicable SEBI requirements and has been appointed by the Company and the Selling Shareholders in consultation with the BRLM to act as a conduit between the Stock Exchanges and NCPL to push the UPI Mandate Request in respect of RIIs as per the UPI Mechanism, in this case being, ICICI Bank Limited
Sub-Syndicate Members	The sub-syndicate members, if any, appointed by the BRLM and the Syndicate Members, to collect Bid-cum-Application Forms and Revision Forms.
Stock Exchanges	BSE Limited and National Stock Exchange of India Limited.
Syndicate	BRLM and the Syndicate Members
Syndicate Agreement	The agreement dated August 26, 2019 to be entered into amongst the BRLM, the members of the Syndicate, our Company, the Selling Shareholders and the Registrar to the Offer in relation to the collection of Bids in the Offer by the Syndicate.
Syndicate Members	An Intermediary registered with the SEBI to act as a syndicate member and who are permitted to carry out activities as an underwriter, namely Aryaman Financial Services Limited and Aryaman Capital Markets Limited.
Syndicate / members of the Syndicate	The BRLM and the Syndicate Members
Systemically Important Non-Banking Financial Company	Systemically important non-banking financial company as defined under Regulation 2(1)(z1a) of the SEBI ICDR Regulations.
TRS / Transaction Registration Slip	The slip or document issued by a member of the Syndicate or an SCSB (only on demand), as the case may be, to the Applicant, as proof of registration of the Application.
Underwriters	[●]
Underwriting Agreement	The agreement dated [●] to be entered into between the Underwriters, Registrar to the Offer, the Selling Shareholders and our Company on or after the Pricing Date.
UPI Circulars	The SEBI circular no. SEBI/HO/CFD/DIL2/CIR/P/2018/138 dated November 1, 2018, SEBI circular no. SEBI/HO/CFD/DIL2/CIR/P/2019/50 dated April 3, 2019, SEBI circular no. SEBI/HO/CFD/DIL2/CIR/P/2019/76 dated June 28, 2019 and any subsequent circulars or notifications issued by SEBI in this regard

Term	Description
UPI ID	ID created on Unified Payment Interface (UPI) for single-window mobile payment system developed by the National Payments Corporation of India (NPCI).
UPI Mandate Request	A request (intimating the RII by way of a notification on the UPI application and by way of a SMS directing the RII to such UPI application) to the RII initiated by the Sponsor Bank to authorise blocking of funds on the UPI application equivalent to Bid Amount and subsequent debit of funds in case of Allotment.
UPI Mechanism	The bidding mechanism that may be used by an RII to make a Bid in the Offer in accordance the UPI Circulars to make an ASBA Bid in the Offer
UPI PIN	Password to authenticate UPI transaction
Willful Defaulter	Wilful defaulter as defined under Regulation 2(1)(zn) of the SEBI ICDR Regulations.
U.S. Securities Act	U.S. Securities Act of 1933, as amended.
Working Day	All days, other than second and fourth Saturday of the month, Sunday or a public holiday, on which commercial banks in Maharashtra and Karnataka are open for business as per the SEBI Circular SEBI/ HO/CFD/DIL2/CIR/P/2018/138 dated November 1, 2018, and as per circulars issued by SEBI from time to time.

### Technical / Industry related Terms

Term	Description
AAY	Antyodaya Anna Yojana
Acres	One Acre equals 4046.86 Square Meters
Bagasse	Fibrous pulpy material left over after sugarcane is extracted for its juice
BESCOM	Bangalore Electricity Supply Company Limited
Boxes	One carton of 48 bottles of 180 ml each or 24 bottles of 375 ml each or 12 bottles of 750 ml each
CACP	Commission for Agricultural Costs and Prices
CAGR	Capital Asset Gearing Ratio
Cane Area Reservation	Every designated mill is obligated to purchase from cane farmers within the cane reservation area, and conversely, farmers are bound to sell to the mill.
CCEA	Cabinet Committee on Economic Affairs
CEA	Central Electricity Authority
CESC, Mysore	Chamundeshwari Electricity Supply Corporation Limited
Chiller Compressing	Process of removing heat from a liquid via a vapour-compression or absorption refrigeration cycle
Co-generation	Simultaneous production of heat and electricity
Crushing Season	The period as set by the state government each year during which sugarcane crushing should take place.
Crystallization	Nucleation and growth of crystals.
DCS	Distributed Control System
DGFT	Director General of Foreign Trade
EMDEs	Emerging Markets and Developing Economies
ENA	Extra Neutral Alcohol
ESCOM	Electricity Supply Companies
ESP	Electro Static Precipitator
EY	Ernst and Young
FDI	Foreign Direct Investment
FMCG	Fast Moving Consumer Goods
FRP	Fair and Remunerative Price
G20	G20 is an international forum for governments and central bank governors
GDP	Gross Domestic Product
GESCOM	Gulbarga Electricity Supply Company Limited
GST	Goods and Service Tax
Gunthas	40 Gunthas is equal to 1 Acre
GW	Giga Watt
HESCOM	Hubli Electricity Supply Company Limited
IMARC	Leading Market Research Company

IML	Indian Made (Foreign) Liquor
KL	Kilo Litre
KLPD	Kilo Litre per Day
KSBCL	Karnataka State Beverages Company Limited
KSPCB	Karnataka State Pollution Control Board
KWh	Kilo Watt per Hour
Ltrs.	Litre / Litres
Malt	Malt is germinated cereal grains that have been dried in a process known as "malting"
Mash	Mixture of alcohol, water and bacteria used for manufacture of Vinegar
Massecuite	The mixture of crystals and syrup resulting from the crystallization process.
MESCOM	Mangalore Electricity Supply Company Limited
MH	Million Hectares
Minimum Distance Criteria	Under the Sugarcane Control Order, the central government has prescribed a minimum radial distance of 15 km between any two sugar mills.
MMT	Million Metric Tonnes
Molasses	The syrup separated from the crystals by Centrifuging used for producing alcohol
MT	Metric Tonnes
MW	Mega Watt
MY	Marketing Year
NFSA	National Food Security Act, 2013
OECD	Organisation for Economic Co-operation and Development
PCB	Pollution Control Board
PFC	Power Finance Corporation Ltd
PPA	Power Purchase Agreement
Press-Mud	Industrial Waste available from sugar mills
QA / QC	Quality Assurance / Quality Control
RES (MNRE)	Renewable Energy Sources (Ministry of New and Renewable Energy)
SMP	Statutory Minimum Price
SPV	Special Purpose Vehicle
TCD	Tonnes Crushed per Day
TPDS	Targeted Public Distribution System
TPH	Tonnes per Hour
UMPPs	Ultra Mega Power Projects
Water Scrubbing	Process of biogas upgradation
WEO	World Economic Outlook
WHR Loan	Warehouse Receipt Loan

### Conventional Terms / General Terms / Abbreviations

Term	Description
₹/Rs./ Rupees / INR	Indian Rupees
A/c	Account
ACS	Associate Company Secretary
AGM	Annual General Meeting
AIF	Alternative Investment Fund as defined in and registered with SEBI under the Securities and Exchange Board of India (Alternative Investments Funds) Regulations, 2012
AS / Accounting Standards	Accounting Standards as issued by the Institute of Chartered Accountants of India
ASBA	Application Supported by Blocked Amount
AY	Assessment Year
BTI Regulations	Securities and Exchange Board of India (Bankers to an Issue) Regulations, 1994.
BSE	BSE Limited
CAGR	Compounded Annual Growth Rate
Category I Foreign Portfolio Investors / Category I FPIs	FPIs who are registered with SEBI as "Category I foreign portfolio investors" under the SEBI FPI Regulations.

Term	Description
Category II foreign portfolio investor(s) / Category II FPIs	FPIs who are registered as “Category II foreign portfolio investors” under the SEBI FPI Regulations
Category III foreign portfolio investor(s) / Category III FPIs	FPIs who are registered as “Category III foreign portfolio investors” under the SEBI FPI Regulations
CDSL	Central Depository Services (India) Limited
CAO	Chief Administrative Officer
CFO	Chief Financial Officer
CIBIL	Credit Information Bureau (India) Limited
CIN	Company Identification Number
CIT	Commissioner of Income Tax
Client ID	Client identification number of the Applicant’s beneficiary account
Companies Act	Unless specified otherwise, this would imply to the provisions of the Companies Act, 2013 (to the extent notified) and /or Provisions of Companies Act, 1956 w.r.t. the sections which have not yet been replaced by the Companies Act, 2013 through any official notification.
Companies Act, 1956	The Companies Act, 1956, as amended from time to time
Companies Act, 2013	Companies Act, 2013, to the extent in force pursuant to the notification of the Notified Sections, along with the relevant rules, regulations, clarifications, circulars and notifications issued thereunder
Competition Act	Competition Act, 2002, as amended
CS	Company Secretary
CSR	Corporate Social Responsibility
CST	Central Sales Tax
DIN	Director Identification Number
DP	Depository Participant as defined under the Depositories Act
DP ID	Depository Participant’s identification
EBITDA	Earnings Before Interest, Tax, Depreciation and Amortisation
ECS	Electronic Clearing System
EOGM / EGM	Extraordinary General Meeting
EMDEs	Emerging Market and Developing Economies
EPS	Earnings Per Share
Euro / €	Euro, the official currency of the European Union.
FCNR Account	Foreign Currency Non Resident Account
FDI	Foreign Direct Investment
FEMA	Foreign Exchange Management Act, 1999, as amended from time to time, and the regulations framed there under
FIIs	Foreign Institutional Investors (as defined under Foreign Exchange Management (Transfer or Issue of Security by a Person Resident outside India) Regulations, 2000) registered with SEBI under applicable laws in India
FPIs	Foreign Portfolio Investors as defined under the SEBI FPI Regulations
FIPB	Foreign Investment Promotion Board
FVCI	Foreign Venture Capital Investor registered under the FVCI Regulations.
FVCI Regulations	Securities and Exchange Board of India (Foreign Venture Capital Investors) Regulations, 2000, as amended.
FY / Fiscal / Financial Year	Period of twelve months ended March 31 of that particular year, unless otherwise stated
GDP	Gross Domestic Product
GoI / Government	The Government of India
Gratuity Act	The Payment of Gratuity Act, 1972
GST	Goods & Services Tax
HNI	High Networth Individuals
HUF	Hindu Undivided Family
IAS Rules	Indian Accounting Standards, Rules 2015
ICAI	The Institute of Chartered Accountants of India

Term	Description
ICSI	The Institute of Company Secretaries of India
IEC	Importer Exporter Code
IFRS	International Financial Reporting Standards
Ind AS	Indian Accounting Standards prescribed under section 133 of the Companies Act, 2013, as notified under the Companies (Indian Accounting Standard) Rules, 2015
Ind AS Rules	Companies (Indian Accounting Standards) Rules, 2015
India	The Republic of India
Indian GAAP	Generally Accepted Accounting Principles in India
Insolvency and Bankruptcy Code, 2016	The Insolvency and Bankruptcy Code, 2016, as amended
IT	Information Technology
I. T. Act / Income Tax Act	Income Tax Act, 1961, as amended from time to time
I. T. Department	Income Tax Department, GoI.
IPO	Initial Public Offering
ISIN	International Securities Identification Number
KM / Km / km	Kilo Meter
LIBOR	London Interbank Offered Rate
Limited Liability Partnership or LLP	Limited Liability Partnership registered under the Limited Liability Partnership Act, 2008.
MCLR	Marginal Cost of funds based Lending Rates
Merchant Banker	Merchant Banker as defined under the Securities and Exchange Board of India (Merchant Bankers) Regulations, 1992
MoF	Ministry of Finance, Government of India
MICR	Magnetic ink character recognition
MOU	Memorandum of Understanding
NA / N. A.	Not Applicable
NAV	Net Asset Value
NECS	National Electronic Clearing Service
NEFT	National Electronic Fund Transfer
No.	Number
NoC	No Objection Certificate
NR or Non Resident	A person resident outside India, as defined under FEMA, including an Eligible NRI and FII
NRE Account	Non Resident External Account
NRIs	A person resident outside India, as defined under FEMA and who is a citizen of India or a person of Indian origin, such term as defined under the Foreign Exchange Management (Deposit) Regulations, 2000.
NRO Account	Non Resident Ordinary Account
NSDL	National Securities Depository Limited
NSE	National Stock Exchange of India Limited
OCB / Overseas Corporate Body	A company, partnership, society or other corporate body owned directly or indirectly to the extent of at least 60.00% by NRIs including overseas trusts, in which not less than 60.00% of beneficial interest is irrevocably held by NRIs directly or indirectly and which was in existence on October 3, 2003 and immediately before such date had taken benefits under the general permission granted to OCBs under FEMA
p.a.	Per annum
P/E Ratio	Price/Earnings Ratio
PAC	Persons Acting in Concert
PAN	Permanent Account Number
PAT	Profit After Tax
PBT	Profit Before Tax
PCB	Pollution Control Board
PLR	Prime Lending Rate
QA	Quality Assurance
QC	Quality Check / Control



Term	Description
R & D	Research and Development
RBI	The Reserve Bank of India
ROE	Return on Equity
RONW	Return on Net Worth
RTGS	Real Time Gross Settlement
SCRA	Securities Contract (Regulation) Act, 1956, as amended from time to time
SCRR	Securities Contracts (Regulation) Rules, 1957, as amended from time to time
SEBI	Securities and Exchange Board of India
SEBI Act	Securities and Exchange Board of India Act, 1992
SEBI AIF Regulations	Securities and Exchange Board of India (Alternative Investments Funds) Regulations, 2012
SEBI FII Regulations	Securities and Exchange Board of India (Foreign Institutional Investors) Regulations, 1995
SEBI FPI Regulations	Securities and Exchange Board of India (Foreign Portfolio Investors) Regulations, 2014
SEBI FVCI Regulations	Securities and Exchange Board of India (Foreign Venture Capital Investor) Regulations, 2000
SEBI ICDR Regulations	Securities and Exchange Board of India (Issue of Capital and Disclosure Requirements) Regulations, 2009, as amended from time to time.
SEBI ICDR Regulations 2018	Securities and Exchange Board of India (Issue of Capital and Disclosure Requirements) Regulations, 2018, as applicable
SEBI LODR Regulations, 2015 / SEBI Listing Regulations	Securities and Exchange Board of India (Listing Obligations and Disclosure Requirements) Regulations, 2015 notified on September 2, 2015, as amended from time to time.
SEBI SAST Regulations	Securities and Exchange Board of India (Substantial Acquisition of Shares and Takeovers) Regulations, 2011.
Sec.	Section
Securities Act	U.S. Securities Act of 1933, as amended
SICA	Sick Industrial Companies (Special Provisions) Act, 1985
STT	Securities Transaction Tax
TAN	Tax Deduction Account Number allotted the Income Tax Act, 1961, as amended from time to time.
TIN	Taxpayers Identification Number
TDS	Tax Deducted at Source
UPI	Unified Payment Interface, a payment mechanism that allows instant transfer of money between any two persons bank account using a payment address which uniquely identifies a person's bank account
US/United States	United States of America
USD/ US\$/ \$	United States Dollar, the official currency of the Unites States of America
VAT	Value added tax
VCFs / Venture Capital Fund	Foreign Venture Capital Funds (as defined under the Securities and Exchange Board of India (Venture Capital Funds) Regulations, 1996) registered with SEBI under applicable laws in India.
w. r. t.	With Respect To
Y-O-Y	Year-over-Year

## CERTAIN CONVENTIONS AND PRESENTATION OF FINANCIAL

*This Red Herring Prospectus has been prepared in accordance with provisions and disclosure requirements of the SEBI ICDR Regulations except that the issue procedure including in relation to Bid/Offer Period, submission of Bid Cum Application Forms, Payment of Bid Amount, Allocation, Allotment, Refund of Bid Amount, if any and listing of the Equity Shares as described in the “General Information Document for Investing in Public Issues” (each read with “Definition and Abbreviations” on page no. 1 of this Red Herring Prospectus) has been prepared in accordance with SEBI ICDR Regulations, 2018.*

### Certain Conventions

All references to “India” contained in this Red Herring Prospectus are to the Republic of India. In this Red Herring Prospectus, our Company has presented numerical information in “lakhs” units. One lakh represents 1,00,000.

This Red Herring Prospectus may contain conversions of certain US Dollar and other currency amounts into Indian Rupees that have been presented solely to comply with the requirements of the SEBI ICDR Regulations. These conversions should not be construed as a representation that those US Dollar or other currency amounts could have been, or can be converted into Indian Rupees, at any particular rate.

### Financial Data

Unless stated otherwise, the financial information in this Red Herring Prospectus is derived from our Restated Financial Statements. Certain additional financial information pertaining to our Group Companies is derived from their respective financial statements. The Restated Financial Statements included in this Red Herring Prospectus are as at and for the Fiscals ended March 31, 2019, March 31, 2018, March 31, 2017, March 31, 2016 and March 31, 2015, and have been prepared in accordance with Ind AS as prescribed under Section 133 of Companies Act, 2013 read with Companies (Indian Accounting Standards) Rules, 2015 and other relevant provisions of the Companies Act, 2013 and the guidance notes issued by ICAI. For further information, see “*Financial Information*” beginning on page no. 202 of this Red Herring Prospectus.

In this Red Herring Prospectus, any discrepancies in any table between the total and the sum of the amounts listed are due to rounding off. All figures in decimals have been rounded off to the second decimal and all percentage figures have been rounded off to two decimal places.

Our Company’s financial year commences on April 1 and ends on March 31 of the next year. Accordingly, all references to a particular financial year, unless stated otherwise, are to the 12 month period ended on March 31 of that year. Unless stated otherwise, or the context requires otherwise, all references to a “year” in this Red Herring Prospectus are to a calendar year.

Unless the context otherwise indicates, any percentage amounts, as set forth in “*Risk Factors*”, “*Our Business*” and “*Management’s Discussion and Analysis of Financial Conditions and Results of Operations*” on page nos. 17, 130 and 252 respectively, of this Red Herring Prospectus, and elsewhere in this Red Herring Prospectus have been calculated on the basis of the Restated Financial Statements of our Company.

### Currency and Units of Presentation

All references to:

- “Rupees” or “₹” or “INR” or “Rs.” are to the Indian Rupee, the official currency of India;
- “USD” or “US\$” are to the United States Dollar, the official currency of the United States; and
- “Euro” or “€” are to the Euro, the official currency of the European Union.

### Definitions

For definitions, please refer the Chapter titled “*Definitions and Abbreviations*” on page no. 1 of this Red Herring Prospectus. In the Section titled “*Main Provisions of the Articles of Association of our Company*” beginning on page no. 347 of this Red Herring Prospectus, defined terms have the meaning given to such terms in the Articles of Association.

## **Industry and Market Data**

Unless stated otherwise, the industry and market data and forecasts used throughout this Red Herring Prospectus has been obtained from industry sources as well as Government Publications. Industry sources as well as Government Publications generally state that the information contained in those publications has been obtained from sources believed to be reliable but that their accuracy and completeness and underlying assumptions are not guaranteed and their reliability cannot be assured. Further, the extent to which the industry and market data presented in this Red Herring Prospectus is meaningful depends on the reader's familiarity with and understanding of the methodologies used in compiling such data. There are no standard data gathering methodologies in the industry in which we conduct our business, and methodologies and assumptions may vary widely among different industry sources.

The extent to which the market and industry data used in this Red Herring Prospectus is meaningful depends on the reader's familiarity with and understanding of the methodologies used in compiling such data. There are no standard data gathering methodologies in the industry in which the business of our Company is conducted, and methodologies and assumptions may vary widely among different industry sources. Accordingly, investment decisions should not be based solely on such information.

In accordance with the SEBI ICDR Regulations, "*Basis for Offer Price*" on page no. 108 of this Red Herring Prospectus includes information relating to our peer group entities. Such information has been derived from publicly available sources, and neither we, nor the BRLM has independently verified such information. Such data involves risks, uncertainties and numerous assumptions and is subject to change based on various factors, including those discussed in "*Risk Factors*" on page no. 17 of this Red Herring Prospectus.

## FORWARD-LOOKING STATEMENTS

All statements contained in this Red Herring Prospectus that are not statements of historical fact constitute forward-looking statements. All statements regarding our expected financial condition and results of operations, business, plans and prospects are forward-looking statements. These forward-looking statements include statements with respect to our business strategy, our revenue and profitability, our projects and other matters discussed in this Red Herring Prospectus regarding matters that are not historical facts. Investors can generally identify forward-looking statements by the use of terminology such as “aim”, “anticipate”, “believe”, “expect”, “estimate”, “intend”, “objective”, “plan”, “project”, “may”, “will”, “will continue”, “will pursue”, “contemplate”, “future”, “goal”, “propose”, “will likely result”, “will seek to” or other words or phrases of similar import. All forward looking statements (whether made by us or any third party) are predictions and are subject to risks, uncertainties and assumptions about us that could cause actual results to differ materially from those contemplated by the relevant forward-looking statement.

Forward-looking statements reflect our current views with respect to future events and are not a guarantee of future performance. These statements are based on our management’s beliefs and assumptions, which in turn are based on currently available information. Although we believe the assumptions upon which these forward-looking statements are based are reasonable, any of these assumptions could prove to be inaccurate, and the forward-looking statements based on these assumptions could be incorrect.

Further the actual results may differ materially from those suggested by the forward-looking statements due to risks or uncertainties associated with our expectations with respect to, but not limited to, regulatory changes pertaining to the industries in India in which our Company operates and our ability to respond to them, our ability to successfully implement our strategy, our growth and expansion, technological changes, our exposure to market risks, general economic and political conditions in India and overseas which have an impact on our business activities or investments, the monetary and fiscal policies of India and other jurisdictions in which we operate, inflation, deflation, unanticipated volatility in interest rates, foreign exchange rates, equity prices or other rates or prices, the performance of the financial markets in India and globally, changes in domestic laws, regulations and taxes, changes in competition in our industry and incidence of any natural calamities and/or acts of violence. Other important factors that could cause actual results to differ materially from our expectations include, but are not limited to, the following:

- Changes in laws and regulations relating to the sectors/areas in which we operate;
- Inability to identify the new premises may adversely affect the operations, finances and profitability of the Company;
- Uncertainty regarding the sugar market, sugar & allied products’ prices, economic conditions and other factors beyond our control;
- Inability to identify or effectively respond to consumer needs, expectations or trends in a timely manner;
- Our ability to successfully implement our growth strategy and expansion plans, and to successfully launch and implement various projects;
- Volatility of Loan interest rates and inflation;
- Our failure to keep pace with rapid changes in technology;
- Our ability to meet our further capital expenditure requirements;
- Fluctuations in operating costs;
- Our ability to attract and retain qualified personnel;
- Conflict of Interest with affiliated companies, the promoter group and other related parties;
- Changes in political and social conditions in India, the monetary and interest rate policies of India and other countries;
- General economic and business conditions in the markets in which we operate and in the local, regional, national and international economies;
- Changes in government policies and regulatory actions that apply to or affect our business;
- The performance of the financial markets in India and globally;
- The occurrence of natural disasters or calamities; and
- Failure to successfully upgrade our products and service portfolio, from time to time.

For further discussions of factors that could cause our actual results to differ, please refer the section titled “*Risk Factors*”, “*Business Overview*” and “*Management’s Discussion and Analysis of Financial Condition and Results of Operations*” beginning on page nos. 17, 130 and 252 of this Red Herring Prospectus, respectively.

Neither our Company, our Directors, our Promoter, the Selling Shareholders, the BRLM nor any of their respective affiliates have any obligation to update or otherwise revise any statements reflecting circumstances arising after the

date hereof or to reflect the occurrence of underlying events, even if the underlying assumptions do not come to fruition. In accordance with SEBI requirements, our Company will ensure that investors in India are informed of material developments from the date of this Red Herring Prospectus until the time of the grant of listing and trading permission by the Stock Exchanges. In accordance with SEBI requirements and as prescribed under applicable law, the Selling Shareholders will ensure that investors are informed of material developments in relation to statements and undertakings made by the respective Selling Shareholders from the date of this Red Herring Prospectus until the time of the grant of listing and trading permission by the Stock Exchanges.



## SECTION II - RISK FACTORS

*An investment in our Equity Shares involves a high degree of risk and you should carefully consider all the information in the Red Herring Prospectus, including the risks and uncertainties described below, before making an investment in our Equity Shares. This section addresses general risks associated with the industry in which we operate and specific risks associated with our Company. If any, or some combination, of the following risks actually occurs, our business, prospects, results of operations and financial condition could suffer, the trading price of our Equity Shares could decline and you may lose all or part of your investment.*

*This Red Herring Prospectus also contains forward-looking statements that involve risks and uncertainties. We have described the risks and uncertainties that our management believes are material, but these risks and uncertainties may not be the only ones we face. Additional risks and uncertainties, including those we are not aware of or deem immaterial, may also result in decreased revenues, increased expenses or other events that could result in a decline in the value of our Equity Shares. In making an investment decision, prospective investors must rely on their own examination of our Company and the Issue, including the merits and risks involved. Unless specified or quantified in the relevant risk factors below, we are not in a position to quantify the financial or other implications of any of the risks described in this section. Investors are advised to read the risk factors carefully before taking an investment decision in this Issue. Investors should not invest in this Issue unless they are prepared to accept the risk of losing all or part of their investment, and they should consult their tax, financial and legal advisors about the particular consequences to you of an investment in the Equity Shares.*

*To obtain a better understanding of our business, you should read this section in conjunction with other chapters of the Red Herring Prospectus, including the chapters titled “Our Business”, Management’s Discussion and Analysis of Financial Condition and Results of Operations” and “Financial Information” on page nos. 130, 252 and 202 respectively of this Red Herring Prospectus, together with all other financial information contained in the Red Herring Prospectus. Our actual results could differ materially from those anticipated in these forward looking statements as a result of certain factors, including the considerations described below and elsewhere in this Red Herring Prospectus.*

*Unless otherwise stated, the financial data in this chapter is derived from our restated financial information prepared in accordance with Indian GAAP included in chapter titled “Financial Information” on page no. 202 of this Red Herring Prospectus.*

### **Internal Risks**

#### **1. We have in the past, made certain issuances and allotments of our equity shares which may not be in compliance with the applicable provisions and rules of the Companies Act, 1956.**

During the period October 01, 2007 to March 31, 2008, we had made certain allotments wherein an aggregate of 9,564 Equity Shares of ₹ 1,000/- each. The said allotments were made in 43 different tranches, wherein the number of allottees was below the threshold limit of 50 in each individual allotment (“collectively the **“Stated Allotments”**”). Secondly in compliance with the applicable provisions of the Companies Act, 1956, we had allotted 5,20,100 Equity Shares of ₹ 10/- each to VSL Shareholders Welfare Trust on December 10, 2010. These shares were held by the trust for a period of around 3 years and subsequently transferred to 9,671 persons / farmers in FY 2013-14 (“**Stated Transfers**”). For further information, see “*Capital Structure – Notes to Capital Structure*” on page no. 70 of this Red Herring Prospectus. We have been given to understand that pursuant to the provisions of the then applicable Companies Act, 1956 and the recent judicial pronouncements, any invitation or offer to subscribe for shares made to 50 persons or more in any Financial Year, may be perceived as a Public Offer. Hence the Stated Allotments and the Stated Transfer may not have been in compliance with the provisions governing public offerings, including, inter alia, issuance and registration of a prospectus.

Pursuant to a press release dated November 30, 2015 and circulars no. CIR/CFD/DIL3/18/2015 dated December 31, 2015 and May 3, 2016 (collectively, the “SEBI Circular”), SEBI has provided that companies involved in issuance of securities to more than 49 persons but up to 200 persons in a Fiscal Year may avoid penal action subject to fulfilment of certain conditions. These conditions include the provision of an option to the current holders of the equity shares allotted to surrender such equity shares at an exit price not less than the amount of subscription money paid along with 15% interest per annum or such higher return as promised to investors.

While we have made allotments to more than 200 individuals in FY 2007-08 and we have registered the transfer to more than 200 individuals in FY 2013-14, recognizing the intent of SEBI through the SEBI Circular, our Board, in its meeting held on August 31, 2017, voluntarily authorized our Promoters to provide an exit offer to those

shareholders (“Eligible Shareholders” and such exit offers, the “Exit Offer”) who held, as on a specified record date (a) Equity Shares allotted by the Company through the Stated Allotments (including through split of the face value of the Stated Shares), and/ or (b) Equity Shares held by persons on account of the Transferred Shares, acquired either through direct allotment / transfer or secondary acquisition. Subsequently, invitations were issued through Offer Letter to all the relevant Eligible Shareholders to offer the stated Equity Shares held by them on the record date for sale to our Promoters at a purchase price calculated in accordance with the SEBI Circulars. All the formalities pertaining to the above have been completed and the relevant confirmations and certificate of the same have been submitted to SEBI as per procedure. For further information, see “Capital Structure – Notes to Capital Structure” on page no. 70 of this Red Herring Prospectus.

We have also e-filed an application on December 19, 2017 with the RoC, as regards the Stated Allotments and the Stated Transfers, seeking to compound any breach of the Companies Act, 1956 on the grounds that (a) the non-compliances with the Companies Act, 1956 were unintentional and inadvertent, and (b) equity shares were allotted / transferred primarily to farmers with the intent of providing them with a meaningful engagement with our Company and granting them sustained benefits of equity interests in our Company, requesting the RoC to compound the offences under section 441 of the Companies Act, 2013. By an order dated October 31, 2018, the Hon’ble NCLT (Bengaluru Bench) rejected our petition due to it being premature and leaving the matter to SEBI to decide the issue in accordance with law at the appropriate time. Further, there was no order as to costs.

We cannot guarantee that we may not be penalised by the Hon’ble NCLT and that SEBI may not initiate appropriate proceedings for violating public issue norms including adjudication proceedings against the Company. Also, we may be subject to complaints in the future regarding the said violations. If any of the above events were to occur, we have to divert substantial resources including our management’s concentration on such proceedings or complaints or both. Any such proceeding or action or any adverse order may result in fines, penalties, payment of additional amounts and potentially criminal liability and adversely affect our Company’s ability to raise funds, its reputation, financial condition, results of operations and the trading prices of the Equity Shares. Further, our Promoters, namely, Mr. Umesh Katti and Nikhil Katti (“Acquirer Promoters”) have undertaken to redress any complaints received by them in future regarding the Exit Offers and any such complaint may result in our Acquirer Promoters to devote substantial time to such complaints and their redressal and may also involve financial penalties and / or fines.

**2. Our Promoters & Promoter Group are offering their shares or part thereof in this Offer under the Offer Sale which constitutes a significant percentage of the total Offer for Sale portion. Further the allocation to QIBs in this Offer is only 10% of the Offer size.**

Our Promoters & Promoter group are part of the Selling Shareholders who have agreed to sell their shareholding or part thereof in this Offer through the Offer for Sale (“OFS”). Our Promoters / Promoter Group have offered shares aggregating to 64,00,550 Equity Shares constituting 64.01% of the total Offer size. The above offered shares will decrease the total pre-Offer Promoter / Promoter Group shareholding of 54.20% to post-Offer shareholding of 32.38%. Further, in this Offer our Company has only earmarked not more than 10% allocation to QIBs, while 50% allocation has been earmarked for Retail Individual Investors and 40% allocation for Non-Institutional Investors.

**3. Our Company, Promoters and Directors are parties to certain legal proceedings. Any adverse decision in such proceedings may have a material adverse effect on our business, results of operations and financial condition.**

Our Company, Promoter and Directors are parties to certain legal proceedings. These legal proceedings are pending at different levels of adjudication before various courts, tribunals and forums. Mentioned below are the details of the proceedings involving our Company, Promoter and Directors as on the date of this Red Herring Prospectus along with the amount involved, to the extent quantifiable, based on the materiality policy for litigations, as approved by the Company in its Board meeting held on December 18, 2017.

Sr. No.	Nature of Case	No. of Outstanding cases	Amount in dispute/demanded to the extent quantifiable (in ₹)
<b>I.</b>	<b>Litigations against our Company</b>		
(a)	Criminal	1	1,76,273/-
(b)	Statutory Actions	3	31,77,760/-
(c)	Central Excise	9	1,17,68,501/-
(d)	Others	3	1,02,75,000/-
<b>II.</b>	<b>Litigations filed by the Company</b>		
(a)	Criminal	39	2,69,17,508/-

(b)	Actions by Statutory/Regulatory Authorities	1	Unascertainable
(c)	Central Excise	4	8,73,44,965/-
(d)	Custom Duty	2	1,77,79,527.26/-
(e)	Others	3	9,09,72,058/-
<b>III.</b>	<b>Litigations filed against our Directors</b>		
(a)	Criminal	1	67,44,794/-
<b>IV.</b>	<b>Litigations filed by our Promoters</b>		
(b)	Criminal	1	67,44,794/-

*The amounts mentioned above may be subject to additional interest rates and/or penalties being levied by the concerned authorities for delay in making payment or otherwise. Amount of interest and/ or penalty that may be levied is unascertainable as on the date of this Red Herring Prospectus.*

There can be no assurance that these litigations will be decided in our favour or in favour of our Company, Promoters and Directors, respectively, and consequently it may divert the attention of our management and Promoters and waste our corporate resources and we may incur significant expenses in such proceedings and may have to make provisions in our financial statements, which could increase our expenses and liabilities. If such claims are determined against us, there could be a material adverse effect on our reputation, business, financial condition and results of operations, which could adversely affect the trading price of our Equity Shares. For the details of the cases filed by and against our Company, Group Companies, Promoters and Directors please refer the chapter titled “*Outstanding Litigations and Material Developments*” on page no. 277 of this Red Herring Prospectus.

**4. *Our business is subject to seasonal variations that could result in fluctuations in our results of operations.***

Our business is seasonal in nature and as a result, our operating results may fluctuate. Since our business is influenced by the availability of our basic raw material, i.e. sugarcane, our production schedules are operational only according to such availability. For example, Belgaum area, the crushing season generally starts from October each year and remains till April. It is during this period that our majority of the sugar production takes place. During the non-crushing season, i.e. May to September, not only is our sugar production affected but also our co-generation and distillery units are affected for the lack of bagasse and molasses. Further, other seasonal factors such as irrigation, seed quality, area of sugarcane production and amount of rainfall also play a role in determining the quantity and quality of sugarcane produce. Consequently, the results of one reporting period may not be necessarily comparable with the preceding, succeeding or corresponding reporting periods. Our revenues recorded during planting and harvesting seasons (i.e. 1<sup>st</sup> half of any financial year) are typically lower or even in losses as compared to revenues recorded during the crushing season (i.e. 2<sup>nd</sup> half of the financial year). During periods of lower sugar production, we continue to incur substantial operating expenses in connection with day to day operations, employees’ salaries, miscellaneous maintenance cost and among other things, product promotion expenses which are not reduced significantly during such periods, while our revenues remain reduced.

We have experienced, and expect to continue to experience, significant variability in our total revenue, operating cash flows, operating expenses and net revenues on a seasonal basis.

**5. *We have incurred losses in the past and in particular for the financial year ended 2018-19, 2017-18 & 2014-15 and may incur losses in the future.***

We have incurred losses in the past i.e. during F. Y. 2018-19, F. Y. 2017-18 and F. Y. 2014-15 for amount of ₹ 1,761.99 lakhs, ₹ 426.67 and ₹ 57.68 lakhs, respectively. In particular, our Sugar Segment, which is the primary manufacturing business of our Company, has incurred significant losses in the past and there is no assurance that it will not incur similar losses in the future. These losses are mainly attributable to the seasonal nature of our business, fluctuating sugar prices, increasing sugarcane prices and / or to period of low overall sugarcane growth and availability. In the event of such loss in the future, our business operations, financial conditions and overall growth will be materially and adversely affected.

**6. *Our business is working capital intensive. If we are unable to generate sufficient cash flows to allow us to make required payments on our debt or fund working capital requirements, there may be an adverse effect on our results of operations.***

Our business is working capital intensive including fund requirement for payment for sugarcane purchase during the crushing season. Hence, major portion of our working capital is utilised towards debtors and inventory. Our

debtors for the F. Y. 2018-19, 2017-18 and 2016-17 was 18.14%, 14.80%, and 19.08% of the total net worth respectively in each year. Our inventories F. Y. 2018-19, 2017-18 and 2016-17 was 153.36%, 114.28%, and 78.28% of the total net worth respectively in each year.

The results of operations of our business are dependent on our ability to effectively manage our inventory (raw material and finished goods) and trade receivables. To effectively manage our inventory, we must be able to accurately estimate customer demand and supply requirements and purchase new inventory accordingly. However, if our management misjudges expected customer demand, it could cause either a shortage of products or an accumulation of excess inventory. Further, if we fail to sell the inventory we manufacture or purchase, we may be required to write-down our inventory or pay our suppliers without new purchases, or create additional vendor financing, all of which could have an adverse impact on our income and cash flows. To effectively manage our trade receivables, we must be able to accurately evaluate the credit worthiness of our customers and dealers and ensure that suitable terms and conditions are given to them in order to ensure our continued relationship with them. However, if our management fails to accurately evaluate the credit worthiness of our customers, it may lead to bad debts, delays in recoveries and / or write-offs which could lead to a liquidity crunch, thereby adversely affecting our business and results of operations. A liquidity crunch may also result in increased working capital borrowings and, consequently, higher finance cost which will adversely impact our profitability.

We have a sanctioned limit for working capital of ₹ 26,500 lakhs from the existing bankers / financial institutions as on March 31, 2019. Our inability to maintain sufficient cash flow, credit facility and other sourcing of funding, in a timely manner, or at all, to meet the requirement of working capital or pay out debts, could adversely affect our financial condition and result of our operations. In the event we are not able to recover our dues from our trade receivables or utilise / sell our inventory, we may not be able to maintain our Sales level and thus adversely affecting our financial health. If this situation persists, we may not be able to pay our lenders / creditors and we may be forced to go for Corporate Debt Restructuring (CDR) which may result in adversely affecting our operations and future prospects.

**7. We have significant amounts of outstanding payment to Sugarcane growers / farmers each year**

We purchase our entire sugarcane requirement directly from various independent farmers from within and outside our reserved area. These farmers sell their produce to us mainly during the crushing season and the payment for the same is settled only once the crushing season is over. Due to this, we show significant amounts of outstanding to the sugarcane farmers who have sold their produce to us. Also, due to various developments and issues affecting the sugar sector, substantial cane payments are outstanding throughout the industry and due to this the Government has vide notification no. 1(4)/S.P.-I. dated March 02, 2019, notified the banks to sanction soft loans to sugar mills for facilitating the cane payables. The outstanding to these farmers year-wise is as shown below:

Sr. No.	Financial year / Period ended	Amount outstanding (₹ in lakhs)
1.	2016-17	693.71
2.	2017-18	1,773.64
3.	2018-19	10,132.96

We have cordial relations with our suppliers i.e. the Sugarcane farmers and the timeframe followed by us for settling the outstanding is generally accepted by these farmers. If we are unable to clear the dues in a timely manner, some farmers may claim immediate payment or legal action for delayed payment, which may affect our cash flows, business operations and financial condition. Further, if such dues are pending for an extended period of time, the farmers may refrain from selling their produce to us and approach our competitors. In such a case, we may not be able to accumulate sufficient raw materials and our business operations and financial results will be adversely affected. Though we have not defaulted in payment to farmers, we cannot guarantee that such an event will not impact our relations and business operations in the future.

**8. Sugarcane is the principal raw material used for the production of sugar. Our business depends on the availability of sugarcane and any shortage of sugarcane may adversely affect our business and results of operations.**

We do not own any land for cultivation of sugarcane and we purchase our entire sugarcane requirement directly from various independent farmers from within and outside our reserved area. After the de-regulation of the sugar sector, the farmers growing sugarcane within the villages around our manufacturing facility are not required to sell the sugarcane to our Company and we need to maintain cordial relations with these farmers to ensure that they sell their produce to us. Also, we strive to maintain relations with farmers in other villages not in our immediate

vicinity so that we have adequate supply of sugarcane during the crushing season. Further, the farmers within our reserved area have no legal or contractual obligation to cultivate sugarcane and may instead grow other crops. If the farmers within our reserved area cultivate other crops, or otherwise limit their cultivation of sugarcane, we may have a shortage of the raw material. We work with the farmers to determine the harvesting schedule and also provide them with subsidised seeds, cutting & transport assistance so that these farmers sell their produce to us. However, if the farmers are able to realise a higher price for sales of sugarcane from other sugar factories or other users, the farmer may have an incentive to sell the sugarcane to parties other than us.

Further, farmers may want to harvest the crop earlier than we have scheduled or grow other crops thereby disrupting our operations. To ensure that the farmers stay interested in selling sugarcane to our Company, we may need to provide financial and other incentives to the farmers. Diversion of sugarcane to other users or other sugar factories may reduce the sugarcane available to us and may adversely affect our financial condition and results of operation.

In addition, adverse weather conditions, crop disease, pest attacks may adversely affect sugarcane crop yields and sugar recovery rates for any given harvest. Our sugar production depends on the volume and sucrose content of the sugarcane that is supplied to us. Crop yields and sucrose content depends primarily on the variety of sugarcane grown, the presence of any crop disease, weather conditions such as inadequate or excess rainfall and temperature which may vary even in a particular season. Adverse weather conditions may adversely affect our manufacturing operations. Flood or drought can adversely affect the supply and pricing of the sugarcane procured by us from the farmers. For e.g. due to heavy rains / floods in 2019, certain media reports estimate that the sugarcane cultivation for the upcoming crushing season might be affected. Accordingly, our business operations and results of operations may be adversely affected to such extent. There can be no assurance that weather patterns, crop disease or the cultivation of certain sugarcane crop varieties will not reduce the amount of sugar that we can recover in any given harvest. Any reduction in the amount of sugar recovered from sugarcane could have a material adverse effect on our business and results of operations.

**9. *The improper handling, processing or storage of raw materials or products, or spoilage of and damage to such raw materials and products, or any real or perceived contamination in our products, could subject us to regulatory and legal action, damage our reputation and have an adverse effect on our business, results of operations and financial condition.***

The products that we manufacture or process are subject to risks such as contamination, adulteration and product tampering during their manufacture, transport or storage. We face inherent business risks of exposure to product liability or recall claims in the event that our products fail to meet the required quality standards or are alleged to result in harm to customers. For example, in our IML segment, although we test our primary raw material, which is ethanol, there could still be some deviation from prescribed quality standards due to factors such as human error. Also, apart from ethanol, certain of our other raw materials and our products are required to be stored, handled and transported under specific conditions and / or temperatures and under certain food safety conditions. Further, products like sugar and vinegar may be subject to contamination which may affect the health of the final consumer. These contaminations may be human induced or natural, and, as a result, there is a risk that they could affect our processed sugar or other products. There is a potential for deterioration of our sugar products as a result of improper handling at the processing, packing, storing or transportation levels, which may adversely affect our customer image.

Such risks may be controlled, but not eliminated, by adherence to good manufacturing practices and finished product testing. We have little, if any, control over proper handling once our products are shipped to our customers. We face the risk of legal proceedings and product liability claims being brought by various entities, including consumers, distributors and government agencies for various reasons including for defective or contaminated products sold or services rendered. For further details, please see “*Outstanding Litigation and Material Developments*” on page no. 277 of this Red Herring Prospectus. If we experience a product recall or are a party to a product liability case, we may incur considerable expense in litigation. We cannot assure that we will not experience product recalls or product liability losses in the future. Further, we do not have any product liability insurance cover and getting such a insurance afresh will require additional cost. Any product recall, product liability claim or adverse regulatory action may adversely affect our reputation and brand image, as well as entail significant costs in excess of available insurance coverage, which could adversely affect our reputation, business, results of operations and financial condition.



**10. Our manufacturing unit and Registered Office are concentrated only in 1 area in India i.e. Bellad Bagewadi near Belgaum. Our results of operations could be materially and adversely affected if such facilities are disrupted due to unforeseen factors including.**

All our manufacturing operations including our Registered Office are based in a single complex which is situated in the area of Bellad Bagewadi near Belgaum, Karnataka. The manufacturing unit is one of the main locations from where we sell our manufactured products including sugar, distillery products, IML and other by-products and also generate power from our co-generation unit. These facilities may be subject to operating risks, such as the breakdown or failure of equipment, power supply or processes, performance below expected levels of output, raw material shortage or unsuitability, obsolescence, labour disputes, strikes, lock-outs, non-availability of services of our external contractors, etc. Further, due to the concentration of our people and other resources at these units, our results of operations could be materially and adversely affected if one or more of those facilities are damaged as a result of a natural disaster, including an earthquake, flood, fire, or other event that disrupts our business or causes material damage to our property. Further, any disruption of transport services and other infrastructure problems may halt or hinder our manufacturing and administrative operations. Since we do not have any back-up facilities, it could be difficult for us to maintain or resume our operations quickly in the aftermath of such a disaster / event. Further, we also do not have any insurance to cover any such loss or damage to our assets.

**11. We derive a significant portion of our revenue from our sugar segment and any reduction in demand or in the production of this product could have an adverse effect on our business, results of operations and financial condition.**

We derive a significant portion of our revenue from our sugar segment, which comprises of sale of different grades of sugar manufactured by us. For the financial years 2018-19, 2017-18 and 2016-17, our revenue from our sugar segment was ₹ 23,402.99 lakhs, ₹ 17,199.74 lakhs and ₹ 21,411.38 lakhs, or 76.28%, 66.34% and 66.53% of our revenue from operations, respectively. Consequently, any reduction in demand or a temporary or permanent discontinuation of manufacturing of sugar could have an adverse effect on our business, results of operations and financial condition.

Further, being an integrated unit, the residue from sugar production i.e. bagasse and molasses are further used as raw materials for generation of power and for distillery products, respectively. In the absence of adequate sugar production, our co-generation unit and our distillery unit will suffer due to lack of in-house raw materials. We may have to acquire these raw materials from external sources, thus increasing our costs. Also, we may not be able to procure these raw materials in the desired quality or at all thus resulting in partial or complete stoppage of these units thus adversely affecting our business operation and financial results.

**12. Substantial portion of our revenues has been dependent upon our few clients. The loss of any one or more of our major clients would have a material effect on our business operations and profitability.**

Our customers include State Governments and Union Territories, Whole Sellers and Retailers. Our top 5 customers for the financial years ended March 31, 2019, March 31, 2018 and March 31, 2017 contributed to our total revenue from operations as below:

Particulars	For year ended					
	March 2019	%	March 2018	%	March 2017	%
Sales from Top 5 Customers	7,986.99	26.03%	5,887.34	22.71%	13,651.52	42.42%

We confirm that none of our top 5 customers have any direct / indirect relation with our Company or our Promoters / Promoter Group. The loss of any significant client would have a material effect on our financial results. We cannot assure you that we can maintain the historical levels of business from these clients / distributors or that we will be able to replace these clients / distributors in case we lose any of them. Furthermore, major events affecting our clients, such as bankruptcy, change of management, mergers and acquisitions could impact our business. If any of our major clients becomes bankrupt or insolvent, we may lose some or all of our business from that client and our receivable from that client would increase and may have to be written off, impacting our income and financial condition.

Besides, currently our entire sale of surplus power is made to five different electricity supply companies forming part of the PPA entered into with them. Similarly, 100% of our IML sales are to KSBCL which is the regulatory

agency in the state of Karnataka for the sale of alcohol products. In the event our PPA is terminated for any reason, or the same is not renewed upon expiration, we will have to sell power in the open market where we cannot guarantee regular sales. Also, if KSBCL reduces its purchase of our IML products for any reason including lack of demand, preference to our competitors, etc., we will not be able to sell our inventory in the open market.

**13. Substantial portion of our purchases are dependent upon our few suppliers. The loss of any one or more of our major suppliers would have a material effect on our business operations and financial condition.**

Our major suppliers are large number of farmers who grow Sugarcane and sell their produce to us for the manufacture of sugar. Considering the large number of farmers and their varying sales in each crushing season, it is not possible to quantify the percentage of purchases made from each farmer. However, besides Sugarcane, we also require other raw materials like fuel, coal, essence blend, malt, chemicals, bottles, etc. Our top 5 suppliers for the financial years ended March 31, 2019, March 31, 2018 and March 31, 2017 contributed to our total purchases as below:

Particulars	For year ended					
	March 2019	%	March 2018	%	March 2017	%
Purchases from Top 5 Suppliers	1,845.34	6.67%	6,308.66	27.80%	1,323.29	10.32%

We confirm that none of our top 5 suppliers have any direct / indirect relation with our Company or our Promoters / Promoter Group. In case we lose any of our significant suppliers, we would have to find an alternative supplier and we cannot guarantee that we will be able to do so in a timely manner or at all. Further, we may not be able to procure the required raw materials at a reasonable cost or of the desired quality which will adversely affect our end product quality and effectively affect our business operations and financial results. Furthermore, our suppliers may choose to increase their prices or increase their concentration on our competitors, and we may not be able to fulfil our requirement in the manner intended. We may not be able to pass on the increase in raw material price to our end product sale price due to various regulatory restrictions and our financial results would be adversely affected due to absorption of the costs.

**14. We had negative net cash flows in the past and may do so in the future.**

The details of Cash flows of the Company as per restated standalone financial statement are as follows:

(₹ in lakhs)

Particulars	Financial Year Ended March 31,				
	2019	2018	2017	2016	2015
Net Cash flow from Operating activities	2,506.27	(5,459.67)	6,169.97	3,000.65	2,553.52
Net Cash Flow from Investing Activities	(1,847.34)	(621.67)	(4,516.22)	(577.33)	(4,991.65)
Net Cash Flow from Financing Activities	(1,220.30)	5,553.43	(5,545.03)	749.19	3,346.29

For details, please refer “Management’s Discussion and Analysis of Financial Conditions and Results of Operations of our Company” on page no. 252 of this Red Herring Prospectus.

If our Company is not able to generate sufficient cash flows, it may adversely affect our business and financial operations.

**15. We have incurred substantial indebtedness which exposes us to various risks which may have an adverse effect on our business and results of operations. We may also be unable to obtain future financing to fund our operations, expected capital expenditure and working capital requirements on favourable terms, or at all.**

As of March 31, 2019 and March 31, 2018, we have ₹ 33,879.42 lakhs and ₹ 31,464.03 lakhs (including current maturities of long term debt but excluding non fund based) respectively, of outstanding debt on our balance sheet. Our level of indebtedness has important consequences to us, such as:

- increasing our vulnerability to general adverse economic, industry and competitive conditions;
- limiting our flexibility in planning for, or reacting to, changes in our business and the industry;

- affecting our credit rating;
- limiting our ability to borrow more money both now and in the future; and
- increasing our interest expenditure and adversely affecting our profitability, since almost all of our debt bears interest at floating rates.

If any of these risks were to materialise, our business and results of operations may be adversely affected. Our business requires funding for capital expenditure and working capital requirements. The actual amount and timing of future capital expenditure may depend on several factors, among others, new opportunities, availability of land, regulatory approvals, regulatory changes, economic conditions, technological changes and market developments in our industry. Our sources of additional funding, if required, to meet our capital expenditure may include the incurrence of debt or the issue of equity or debt securities or a combination of both. If we decide to raise additional funds through the incurrence of debt, our interest and debt repayment obligations will increase, and could have a significant effect on our profitability and cash flows and we may be subject to additional covenants, which could limit our ability to access cash flows from operations. In case there is insufficient cash flow to meet our working capital requirement or we are unable to arrange the same from other sources or there is delay in disbursement of arranged funds, or there is any increase in interest rate on our borrowings, it may adversely affect our operations and profitability. These factors may result in an increased amount of short-term borrowings. Continuous increase of our working capital requirements may have an adverse effect on our results of operations and financial condition.

Further our ability to arrange for additional funds on acceptable terms is subject to a variety of uncertainties, including future results of operations, financial condition and cash flows; economic, political conditions and market scenario for our products; costs of financing, liquidity and overall condition of financial and capital markets in India; issuance of necessary business/government licenses, approvals and other risks associated with our businesses; and limitations on our ability to raise capital in capital markets and conditions of the Indian and other capital markets in which we may seek to raise funds. Any such inability to raise sufficient funds could have a material adverse effect on our business and results of operations.

***16. We manufacture and sell IML products only in the State of Karnataka which is characterised by regulatory restrictions. We are dependent on government agencies for distribution and sale of our IML products and any change in government policies will adversely affect our business operations.***

Generally, IML products can be distributed by way of auctions, government channelized markets, licensed shops, etc. However, in the State of Karnataka, the distribution of any liquor is controlled only through government agency viz. Karnataka State Beverages Corporation Limited (KSBCL). We are dependent on various depots of KSBCL for sale of our IML products. Since, KSBCL is the sole distributor in the State, it also has a say in the distribution patterns in the State. Due to this, we are unable to take advantage of the market demand as we cannot directly sell our IML products. KSBCL appoints specific personnel in our IML manufacturing unit who monitor our production and supply to KSBCL and also submit periodic reports for the same. Any change in government policies in respect of production, distribution or marketing of IML products may materially and adversely affect our business operations and in turn adversely affect the financials of our Company.

Further, since our entire sales are through KSBCL, it also is responsible for ensuring timely payment to us. Any material failure or inability, financial or otherwise, on the part of KSBCL to fulfil its obligations in respect of sales and payments towards our products would have a material adverse affect on the business and operations of our Company.

***17. In the past, our sugar was seized and godown sealed for not having supplied levy sugar to the Government as per the provisions under Levy Sugar Supply (Control) Order, 1979***

In the year 2013, our Company's sugar was seized by the Government authorities pursuant to the provisions under Levy Sugar Supply (Control) Order, 1979. The Company had filed Writ Petition No.83223 of 2013 and Writ Petition No.19874 of 2013 before the Hon'ble High Court of Karnataka, Dharwad Bench ("the Hon'ble High Court") challenging certain orders under which directions were issued by recovery of levy sugar from the Company for the seasons 2005-2009. In this regard the Company sugar was seized September 26, 2013 and the godwon was sealed. However, the aforesaid seizure was released within a short period of less than three (3) months and the matter is currently pending before the Hon'ble Supreme Court of India. For details pertaining to the said matter, please see the chapter titled "Outstanding Litigations and Material Developments" on page no. 277 of this Red Herring Prospectus. However, occurrence of such seizures or seal in the future may adversely impact our business, reputation, financial conditions and results of operations.

18. *Our Power Purchase Agreement (PPA) includes certain restrictive covenants which may limit our ability to carry out our co-generation business operations. Our PPA may be terminated without cause, which could have an adverse impact on our co-generation business.*

We have, on February 17, 2017, entered into a Power Purchase Agreement (“PPA”) with 5 Electricity Supply Companies (“ESCOs”) in the state of Karnataka, namely, Bangalore Electricity Supply Company Limited (“BESCOM”), Mangalore Electricity Supply Company Limited (“MESCOM”), Gulbarga Electricity Supply Company Limited (“GESCOM”), Hubli Electricity Supply Company Limited (“HESCOM”) and Chamundeshwari Electricity Supply Corporation Limited (CESC, Mysore). This agreement is valid for a period of five (5) years from the date of commencement of power supply. This agreement requires us to comply with the code of conduct and rules and regulations prescribed by the ESCOS in relation to rates and charges, billing and payment, metering and communication to name a few. The ESCOS also have the right to terminate service contracts in the event we do not comply with their requirements or our power supply fails to meet the quality standards set out in our agreement. In the event that we are unable to meet such obligations, the ESCOS may terminate the agreements and we may be required to pay compensation on terms set out in the agreement. Compliance with these requirements may restrict our ability to undertake certain business operations and may increase our compliance costs.

Further, in case of any termination, we may have to sell our surplus power in the open market which may violate certain State regulations. Also, we cannot guarantee that we will be able to negotiate the best price per unit of electricity in case of an open sale including the credit risk of payment from multiple small power purchasers. Further, we cannot guarantee that we will be able to sell our surplus power in part or at all in which case our co-generation operations may be affected, in turn causing an adverse impact on our overall business operations, reputation and financial condition.

19. *Our Company in the past has entered into Related Party Transactions and may continue to do so in future also, which may adversely affect our competitive edge and better bargaining power if entered with non-related parties resulting into relatively more favourable terms and conditions and better margins.*

Our Company has entered into related party transactions with our Promoters / Promoter Group, Directors and the Group Companies aggregating ₹ 932.05 lakhs as on the last financial year ended March 31, 2019. Further, the details such transactions for the last five (5) years are as given below:

(₹ in lakhs)

Name of Related Party	As at March 31,				
	2019	2018	2017 (Proforma)	2016 (Proforma)	2015 (Proforma)
<b>Directors Remuneration</b>					
Nikhil Katti	36.00	36.00	34.50	18.00	18.00
Mukesh Kumar	2.25	-	3.00	5.00	15.00
Mallikarjun Pujar	9.00	9.00	8.75	6.00	6.00
Lava Katti	24.00	24.00	23.00	12.00	12.00
Kush Katti	24.00	24.00	23.00	12.00	12.00
<b>Salary</b>					
Sneha Patil	4.20	4.20	4.00	3.00	3.00
Sheshagiri Kulkarni	4.71	4.68	4.60	3.18	3.12
<b>Purchases</b>					
Nikhil Katti	4.52	0.86	6.65	15.66	8.49
Mallikarjun Pujar	0.39	0.33	-	3.15	4.38
Lava Katti	10.71	2.16	0.09	0.36	6.50
Kush Katti	10.91	22.39	19.77	0.27	10.44
Umesh V. Katti	10.19	26.28	-	-	8.56
Basavaraj V Hagaragi	0.40	0.98	-	-	-
Sheela Umesh Katti	-	-	2.45	-	-
Ramesh Katti	20.54	-	-	-	-
<b>Purchase Advance</b>					
Nikhil U Katti	40.78	40.78	-	-	-
Lava R Katti	52.47	52.47	-	-	-
Kush R Katti	57.24	57.24	-	-	-
<b>Advances</b>					

Mallikarjun Pujar	-	-	3.13	5.00	-
<b>Lease Security Deposit</b>					
Nikhil Katti	200.00	200.00	200.00	200.00	200.00
<b>UR Agro Fresh Pvt. Ltd.</b>					
Sales	93.46	-	-	-	-
Debtors outstanding	83.46	-	-	-	-
Advance Opening Balance o/s	100.00	-	-	-	-
Advance given during the year	225.00	100.00	-	-	-
Closing Balance o/s	335.00	100.00	-	-	-
<b>UK 27 Hospitality Services (India) Ltd.</b>					
Sales	0.47	-	-	-	-
Debtors outstanding	0.22	-	-	-	-
Expenses	0.47	-	-	-	-
Payable Outstanding	0.14	-	-	-	-
<b>M/s. Vishwaraj Developers</b>					
Sales	0.34	-	-	-	-

While our Company believes that all such transactions have been conducted on the arms length basis, there can be no assurance that it could not have been achieved on more favourable terms had such transactions not been entered into with related parties. Furthermore, it is likely that our Company will enter into related party transactions in the future. There can be no assurance that such transactions, individually or in the aggregate, will not have an adverse effect on our financial condition and results of operation. For details, please refer to “Annexure VI – Note - 34 - Related Party Transactions” on page no. 238 of this Red Herring Prospectus.

**20. Our Company’s IML products lack adequate brand presence and awareness and also have geographical presence limited to the State of Karnataka.**

Our Company’s IML manufacturing, products and brand presence is limited to the State of Karnataka. Since the sales of IML in the State of Karnataka is strictly regulated and it is routed through only KSBCL, we cannot directly sell our IML products to any other state or region except under specific orders from KSBCL. Our total sales of IML for the financial years ended 2018-19, 2017-18 and 2016-17 amounted to 8.44%, 18.37% and 15.08% of the total sales, respectively. Our business is therefore significantly dependent on the general economic condition and activity in the State of Karnataka along with the State Government policies relating to distribution of liquor products in this region. Although we have good and cordial relations with KSBCL over the years, there can be no assurance that we will not face any issues relating to pricing, distribution and payment with them. Due to this restriction, many of our competitors in other States in India have been able to capture a larger national market. Continuation of this arrangement may place us at a competitive disadvantage and limit our growth opportunities. Our Company’s failure or inability to continue its presence in the State of Karnataka and establish ourselves in other states may impede its growth and business prospects as compared to established players.

**21. We have acquired certain land for a proposed expansion, where the power of attorney (‘POA’) holder for the seller is the CAO (earlier Whole time Director) of our Company. Further, the final sale deed has not yet been executed.**

Our Company has acquired certain lands in the Navage village, near Belgaum from third parties, wherein, the sellers, being aged individuals or due to pre-occupation had expressed their inability to carry out the various statutory & regulatory formalities for executing the sale to a corporate entity. Accordingly, these sellers have given specific Power of Attorneys (PoAs) to our CAO, Mr. Mallikarjun Pujar (earlier Whole Time Director), for carrying out the various activities pertaining to the sale. Despite the PoA holder being our Whole time Director and also that the payment for the same has been made to the respective sellers (or their representatives, being other family members holding valid bank accounts), the final sale deed has not yet been executed and hence the land is officially not yet in the name of the Company. If we fail to execute the same, we may lose whole or part of the purchase consideration paid for such lands thus affecting our financial condition and results. Further, inability to execute the sale deed may also disrupt our intention of expansion and thus affect our future business plans, business operations and our growth prospects.



**22. *Inability to set / control the cost of sugarcane or the selling price of sugar may impact our profitability.***

Our profitability depends significantly on the cost of sugarcane, our raw material, and the selling price of sugar. We are neither able to set the cost of sugarcane nor the selling price for our sugar. The price we pay for sugarcane is determined by the Government of India and / or the State Government of Karnataka, where our manufacturing unit is located and we may be adversely affected by rising sugarcane prices, particularly in the event of a decrease in the price of sugar.

We purchase all of the sugarcane that we use in our production of sugar from the independent sugarcane farmers within our vicinity and through their some sugarcane farmers' societies located in outside our vicinity. The Government of India and / or the State Government of Karnataka, where our manufacturing unit is located, annually declares the sugarcane procurement price. The procurement price is a minimum price we must pay to sugarcane farmers for sugarcane. The determination of the procurement price is not related to the prevailing market price of sugar and is only loosely related to the quality of sugarcane. For example, political motives may result in the declaration of higher procurement prices. Rising procurement price, particularly if sugar prices remain stable or decrease during the same period, may adversely affect our results of operations and financial condition.

We operate in the sugar industry where the market price for our products is cyclical, while the price at which we procure our raw materials is regulated. These pricing conditions cause our margins to fluctuate and may affect our financial condition, cash flows and results of operation. The sugar industry has historically been cyclical and sensitive to changes in supply and demand. The market in India has experienced periods of limited supply, causing sugar prices and industry profit margins to increase, followed by periods of excess production that result in oversupply, causing declines in sugar prices and industry profit margins. Fluctuations in demand and supply and as a result, the price of our products, occur for various reasons, including:

- changes in the availability and price of our primary raw material, sugarcane;
- variances in the production capacities of our competitors; and
- the availability of substitutes for the sugar products that we produce.

Sugar production in India is currently at low levels as compared to the consumer demand which continues to rise because of population growth, rising income levels, and a shift from traditional sweeteners such as gur and khandsari to sugar. Stronger demand may result in higher prices for sugar. Profitable sugar manufacturers may make prompt payments to farmers who may in turn switch to cultivating sugarcane rather than other crops which have become relatively less profitable. An increase in sugarcane cultivation may lead to an increase in sugar production and a subsequent reduction in sugar prices, which may materially and adversely affect our results of operation and our financial condition.

**23. *We have increased the Director's remuneration for the financial year ended March 31, 2017.***

During the financial year ended March 31, 2017, our Company had substantially increased its operations, mainly due to its increase of sugar crushing capacity from 5,500 TCD to 8,500 TCD and also had recently started the new segment of Vinegar manufacturing, which required additional responsibility and time from the executive Directors of the Company. Also, our Company in the same time period initiated its intention for setting up of a 2<sup>nd</sup> integrated unit for manufacture for sugar and allied products which requires the planning expertise and continued presence of our Directors. Considering the above enhanced responsibility, the Board, after following due process of law, had approved the increase in Director's Remuneration. We cannot guarantee that firstly, this increase will give us the desired output and that our expansion plans within the existing unit and proposed units will be executed successfully. Further, with the increased capacities, we may have to further increase their remuneration in subsequent years, thus affecting our profitability. Our Company has to ensure that the applicable provisions of the Companies Act, 2013 are adhered to in the course of past increases and further increase, if any. If we fail to ensure compliance with the Companies Act, 2013, we may be liable to penalty and / or regulatory action, which may disrupt our business operations and financial results.

**24. *Our Company has not entered into any long-term contracts with any of its customers for sale of sugar and we typically operate on the basis of orders. Inability to maintain regular order flow would adversely impact our revenues and profitability***

Our Company has had long standing business relationships with various sugar customers and has been supplying our product to such customers for several years. However, we have not entered into any contracts with these customers and we cater to them on an order-by-order basis. As a result, our customers can terminate their

relationships with us without any notice and, without consequence, which could materially and adversely impact our business. Consequently, our revenue may be subject to variability because of fluctuations in demand for our manufactured sugar product. Our Company's customers have no obligation to place order with us and may either cancel, reduce or delay orders. The orders placed by our Company's customers are dependent on factors such as the customer satisfaction with the quality of sugar that our Company provides, varieties of sugar that our Company provides, fluctuation in demand for sugar and the customer's inventory management. Although we place a strong emphasis on quality and timely delivery of our product, in the absence of contracts, any sudden change in the buying pattern of buyers could adversely affect the business and the profitability of our Company.

**25. *Our Company, Promoters and Directors are parties to certain criminal proceedings. Failure to defend these proceedings successfully may have an adverse effect on our reputation.***

Our Company, Promoter, Promoter Group and Directors are parties to certain criminal proceedings. These criminal proceedings are pending at different levels of adjudication before various courts, tribunals and forums. Mentioned below are the details of the proceedings against our Company, Promoters and Directors as on the date of this Red Herring Prospectus.

Sr. No.	Litigations against	No. of Outstanding cases
1.	Our Company	1
2.	Promoters	1 <sup>(1)</sup>
3.	Directors	1 <sup>(1)</sup>

<sup>(1)</sup> Criminal Writ Petition 3895 of 2016 involving our Promoter and Director – Nikhil Umesh Katti

Such proceedings are costly to defend and can materially affect our financial condition, even if we are successful in defending them or effectively redress such complaints. If we or our promoter/director are unsuccessful in defending these proceedings or settling these complaints or disputes, we or our promoter/director may have to bear significant damages. Even if we or our promoter/director are successful in defending or settling them, our reputation could be materially harmed. We are also exposed to the risk of adverse publicity as a result of such complaints. If any of the above scenarios were to occur, they could materially and adversely affect our business, results of operations, financial condition, cash flows, prospects and our reputation. For further details, see the section entitled “*Outstanding Litigation and Material Developments*” on page no. 277 of this Red Herring Prospectus.

**26. *Our operations may be adversely affected by strikes, work stoppages or increased wage demands by our or our contractors' workforce or any other industrial unrest or dispute.***

While we have not experienced any major industrial unrest or dispute in the past, we cannot be certain that we will not suffer any disruption to our operations due to strikes, work stoppages or increased wage demands in the future. Further, if our work force unionizes in the future, collective bargaining efforts by labour unions may divert our management's attention and result in increased costs. We may be unable to negotiate acceptable collective wage settlement agreements with those workers who have chosen to be represented by unions, which may lead to union-initiated strikes or work stoppages. Any shortage of skilled and experienced workers, semi-skilled workers and unskilled workers, caused by such industrial unrest or disputes may adversely affect our business, results of operations and financial condition.

**27. *We are dependent on third party transportation providers for the delivery of raw materials and products. Accordingly, continuing increases in transportation costs or unavailability of transportation services for our products, as well the extent and reliability of Indian infrastructure may have an adverse effect on our business, financial condition, results of operations and prospects.***

We use third party transportation providers for the supply of most of our raw materials and also for some delivery of our products to our customers. This includes transportation for the sugarcane produced by farmers as we provide harvesting and transport (H & T) services to these farmers. Though we enter into H & T agreements with all our H & T agents, we cannot guarantee that there will not be any transportation strikes, which could have an adverse effect on our receipt of our essential raw materials.

In addition, transportation costs in India have been steadily increasing over the past several years. While usually the end consumer bears the freight cost, we may not always be able to pass on these costs to our customers. Continuing increases in transportation costs or unavailability of transportation services for sugarcane and other raw materials may have an adverse effect on our business, financial condition, results of operations and prospects.

Further, India's physical infrastructure is less developed than that of many developed nations, and especially transportation in village areas is dominated by small, uneven and dirt roads, making transportation difficult and slow. Problems with road connectivity to and from small villages and other communication systems or any other public facility could disrupt our normal business activity, including our supply of raw materials and also the delivery of our products to customers by third-party transportation providers. Any deterioration of India's physical infrastructure would harm the national economy, disrupt the transportation of goods and supplies, and add costs to doing business in India. These problems could interrupt our business operations, which could have a material adverse effect on our results of operations and financial condition.

**28. *We do not have long-term agreements with suppliers for our raw materials and an increase in the cost of, or a shortfall in the availability of such raw materials could have an adverse effect on our business and results of operations.***

The basic raw material required by us is sugarcane, which is crushed to produce sugar. The residue generated from the crushing process i.e. bagasse and molasses are used for power generation and distillery units respectively. Sugarcane is supplied to us by various farmers mainly from villages in our vicinity. We do not have any long term agreement with these farmers and also the farmers are not obligated to sell their produce to us. In case these farmers decide to sell their produce to other sugar factories or for any other purposes, we may experience shortage of sugarcane which will not only affect our sugar production operations but also power generation and distillery operations due to lack of bagasse and molasses. We may have to purchase coal for our power unit and molasses for our distillery units from third parties, thus increasing our cost of production.

Further, each segment of our business is also dependent on the availability of other reasonably priced, high quality raw materials in the quantities required by us. Our sugar segment requires various re-agents, all of which are purchased from the open market. Our co-generation segment requires coal for assisting in proper burning of bagasse and also during off-seasons, which is purchased from third parties. Our distillery and IML segment requires various other raw materials like Essence Blend, Malt and several chemicals. Our Vinegar unit requires a special bacterium which is procured vendors outside India. Besides, all the packaging materials for sugar, distillery, IML and vinegar are sourced from local or national suppliers on an invoice basis.

For the financial years 2019, 2018 and 2017, our cost of materials consumed was ₹ 27,665.37 lakhs, ₹ 22,695.78 lakhs and ₹ 12,819.41 lakhs or 89.86%, 84.39% and 39.70% of our total revenue, respectively. The price and availability of the above raw materials depend on several factors beyond our control, including overall economic conditions, weather conditions, production levels, market demand and competition for such materials, production, harvesting and / or transportation cost, duties and taxes and trade restrictions. We usually do not enter into long term supply contracts with any of our raw material suppliers and typically source raw materials from third-party suppliers or the open market. The absence of long-term contracts at fixed prices exposes us to volatility in the prices of raw materials that we require and we may be unable to pass these costs onto our customers, which may reduce our profit margins. We also face a risk that one or more of our existing suppliers may discontinue their supplies to us, and any inability on our part to procure raw materials from alternate suppliers in a timely fashion, or of a desired quality, or on commercially acceptable terms, may adversely affect our operations.

**29. *We require certain approvals and licenses in the ordinary course of business and are required to comply with certain rules and regulations to operate our business, and the failure to obtain, retain and renew such approvals and licenses or comply with such rules and regulations, and the failure to obtain or retain them in a timely manner or at all may adversely affect our operations.***

We require several statutory and regulatory permits, licenses and approvals to operate our business, some of which our Company has either received, applied for or is in the process of application. Many of these approvals are granted for fixed periods of time and need renewal from time to time. Non-renewal of the said permits and licenses would adversely affect our Company's operations, thereby having a material adverse effect on our business, results of operations and financial condition. There can be no assurance that the relevant authorities will issue any of such permits or approvals in the time-frame anticipated by us or at all. Further, we have made a delay in making applications for procuring 2 (two) boiler licenses and may be subject to monetary penalties for the same. Further, some of our permits, licenses and approvals are subject to several conditions and we cannot provide any assurance that we will be able to continuously meet such conditions or be able to prove compliance with such conditions to the statutory authorities, which may lead to the cancellation, revocation or suspension of relevant permits, licenses or approvals or imposition of penalties on us. For further details, kindly refer chapters titled "Key Industry

*Regulations and Policies” and “Government and Other Approvals” beginning on page nos. 156 and 300 respectively of this Red Herring Prospectus.*

**30. *We may not be able to achieve our projected capacity in case of low availability of sugarcane and / or higher sugarcane prices, which may affect our business strategies and financial condition.***

Our primary raw material is sugarcane and the availability of the same depends on various external factors like amount of cane grown by the farmers, weather conditions, sugarcane price (including Fair and Remunerative Price set by the government) and the willingness of the farmers to sell their produce to us. In case of lower availability of sugarcane, we may not be able to achieve the production target set by our management. This may lead to lower revenues, affecting our ability to manage our growth strategies and meet our fixed expenses.

Further, due to the fluctuating nature of our business operations, our historical production data is not comparable to our current data and also may adversely affect our future projections, leading to inflated revenue expectation. We may not be able to ascertain the growth pattern and in turn affect our long term business operations and strategies. If any of the above events were to happen, our business operations and financial conditions will be adversely affected.

**31. *There are certain regulatory matters pending / ongoing against our Company, Promoters, and Directors. Any adverse outcome may affect our reputation and / or business operations.***

There are three on-going statutory proceedings related to Motor Vehicle Accident and Workman’s compensation cases against our Company namely, MVC No. 540/2017 and MVC No. 2321/2016 filed by Shobha Pujeri and M.A. Bicchunnavar before the Motor Accidents Claims Tribunal, Belagavi and W.M.C No. 15/2016 filed by Sunita Waghmare & Anr before the Civil Judge and Workmen Compensation Officer Court, Beed against our Company for claiming a certain compensation amount for the physical injury and death caused due to the motor vehicle of the Company and claiming a certain workman’s compensation from the Company respectively. In pursuance of this, no Orders have been issued by the aforesaid tribunal in these matters and therefore they stand pending as on today. However, with the aforesaid proceedings, we are unable to state whether we can defend such costs that would cause a material impact on the financial condition of the Company. If the Company is unsuccessful in defending these regulatory actions or settling these complaints, the Company may in addition have to bear significant damages. Therefore, any such occurrence of events or defaults in the future could adversely affect and create an impact on the Company’s business, financial condition and the reputation thereof. For further details, see the section entitled “*Outstanding Litigation and Material Developments*” on page no. 277 of this Red Herring Prospectus.

Further, our Company had in the past, made certain issuances and allotments of our equity shares which may not be in compliance with the applicable provisions and rules of the Companies Act, 1956. For details pertaining to the said regulatory matter, please see the chapter “Capital Structure” and the risk factor “We have in the past, made certain issuances and allotments of our equity shares which may not be in compliance with the applicable provisions and rules of the Companies Act, 1956.” on page nos. 69 & 17 of this Red Herring Prospectus.

**32. *Our success depends heavily upon our Promoters and Senior Management for their continuing services, strategic guidance and financial support.***

Our success depends heavily upon the continuing services of promoters and directors, who are the natural person in control of our Company. Mr. Umesh Katti, our Chairman is one of the founding promoters of our Company and has been instrumental in our Company’s overall growth. Mr. Nikhil Katti, our Managing Director has many years of experience in the sugar industry and his and vision has played a key role in obtaining our current market position. We believe that our relation with our Promoters, who have rich experience in setting up business, developing markets, managing customers and handling overall businesses, has enabled us to experience growth and profitability. We benefit from our relationship with our Promoters and our success depends upon the continuing services of our Promoters who have been responsible for the growth of our business and are closely involved in the overall strategy, direction and management of our business. Further, our Promoters have also promoted other companies / firms / ventures and may continue to do so. If they divert their attention to the other companies, we may not be able to function as efficiently and profitably as before. We may have to incur additional costs to replace the services of our promoters or we may not be able to do so at all, which could adversely affect our business operations and affect our ability to continue to manage and expand our business. Further, we also depend significantly on our Key Managerial Persons for executing their day to day activities. If our Promoters / Directors or any member of the senior management team is unable or unwilling to continue in his present position,

we may not be able to replace him easily or at all, and our business, financial condition, results of operations and prospects may be materially and adversely affected.

In addition, we depend on our Executive Directors / Promoters in procuring certain bank loans and for the extension of unsecured loans and advances from time to time. We rely on our Directors and Promoter, in relation to certain of our bank loans for which they have granted certain security and personal guarantees. Further, our Directors have from time to time, extended loans and advances to our Company for various business purposes (“Unsecured Loans”). For details, see “Annexure VI – Note 34 – Related Party Transactions” and chapter titled “Financial Indebtedness” on page nos. 238 and 273 respectively of this Red Herring Prospectus. We cannot assure you that any future financing we obtain without guarantees from our Directors / Promoters will be on terms which are equal to or more favourable than the terms of our past financings.

**33. We sell surplus power through our co-generation facility, which exposes us to certain material risks, some of which are distinct from those relating to our sugar mill operations.**

We operate the co-generation unit which provides us with captive power for our existing sugar unit, distillery unit, vinegar unit and also the office premises. We have a total capacity of 36.4 MW out of which we approximately 22.4 MW is sold as surplus power from our co-generation. However, since our revenue from the co-generation unit for the financial years 2018-19, 2017-18 and 2016-17 is only 7.10%, 6.17% and 5.30% of our total revenues, we may relatively lack experience with respect to our co-generation business which could have a material adverse effect on the financial performance. In addition, our co-generation process is based on bagasse as fuel. The quantity of bagasse available to us is dependent on the amount of sugarcane that is crushed each year. Any constraint in the availability of sugarcane, or our ability to procure bagasse or coal from external sources will result in lower power generation, which could have an adverse effect on our co-generation operations. Further, the generation of electricity involves many significant hazards that could result in fires, explosions, spills, discharge, leaks, release of hazardous materials, and other unexpected or dangerous conditions, accidents and environmental risks. Co-generation facilities are also subject to mechanical failure and equipment shutdown.

Additionally, we sell all of the excess power generated by us to five Electricity Supply Companies in the state of Karnataka, for which we have entered into a Power Purchase Agreement. The price of the power under the said PPA is regulated by the state government and a decrease in the regulatory price will lead to a loss of revenue and may affect our financial condition and results of operation.

**34. We have certain contingent liabilities and our cash flows, financial condition and profitability may be adversely affected if any of these contingent liabilities materialise.**

As of March 31, 2019, the following contingent liabilities were not provided for in our Restated Financial Statements:

		(₹ in lakhs)
Sr. No.	Particulars	As at March 31, 2019
1.	Outstanding guarantees and counter guarantees to various Banks	57.00
2.	Court Cases	1,506.15
3.	Non fulfilment of export obligation under Zero Duty EPCG Scheme	289.99
<b>Total</b>		<b>1,853.14</b>

If any of these contingent liabilities materialise, we may have to fulfil our payment obligations, which may have an adverse impact on our cash flows, financial conditions and results of operations. For further details, please refer “Annexure VI - Note 32 - Contingent Liabilities” on page no. 236 of this Red Herring Prospectus.

**35. It is difficult to predict our future performance, or compare our historical performance between periods, as our revenue fluctuates significantly from period to period.**

Our revenue from sales depends upon the volume of sales of our various products that we are able to sell in relation to our overall production. Our sales largely depend on the availability of sugarcane, being the primary raw material. The availability of sugarcane is dependent on various factors like total area of sugarcane cultivation, rainfall in that year, quality of seeds, harvesting schedules and overall weather conditions. Also, production of sugar is dependent on the recovery of juice from these sugarcanes which is based on the timeline from harvesting of these sugarcanes to crushing. Being a seasonal industry, the availability of sugarcane varies from year to year and our revenues and profits are affected by such seasonal availability.



Our results of operations may also fluctuate from period to period due to the fact that the price of sugarcane is regulated by the state government while the price of sugar is controlled mainly by the cyclical nature of the industry and the demand – supply forces. Further, we cannot guarantee when the crushing season will begin with certainty and the same varies with a range of 15-30 days. A combination of all the above factors, which are mainly beyond our control, affect our operating results in one or more periods and which in turn may impact our cash flows, thereby resulting in our business, financial condition and results of operations being adversely affected. Such fluctuations may also adversely affect our ability to fund future expansions.

As a result of one or more of these factors, we may record significant turnover or profits during one accounting period and significantly lower turnover or profits during prior or subsequent accounting periods. Therefore, we believe that period-to-period comparisons of our results of operations are not necessarily meaningful and should not be relied upon as indicative of our future performance.

**36. *We constantly face a credit risk which may in turn affect our complete buying cycle adversely.***

As a manufacturer of multiple products like sugar, distillery products, IML, vinegar and power generation, our primary competence is the ability to manufacture and market our various products for different customer segments, and hence exploit the benefits of variety and economies of scale in the each segment of our operations. Our requirement of working capital is high mainly due to our ability to procure sugarcane in large quantities during the crushing season and also store sufficient amounts of finished goods for sale in the non-crushing season, thus relieving our units with total disruptions and work stoppages. Once the crushing season starts, we are required to make upfront payments to the farmers, harvesting and transportation teams and other raw material suppliers as is the case in our industry. Besides, we are also required to give sufficient credit period to our customers in order to maintain our customer relations and competitiveness.

Our aforementioned buying cycle is heavily dependent on timely payments being received from our customers. If there is a default in payment from any of our customers or there is any unforeseeable delay in payment, our working capital cycle will be adversely affected. This may lead to our inability to maintain our inventories and thus lack the competitive advantage against various other manufacturers leading to an adverse effect on our business operations and profitability.

**37. *A slowdown or shutdown in our manufacturing operations or under-utilization of our manufacturing facilities could have an adverse effect on our business, results of operations and financial condition.***

As of March 31, 2019, we conduct our operations from our manufacturing facility situated in Bellad Bagewadi near Belgaum, Karnataka, for all our products and for power generation. Our business is dependent upon our ability to manage our manufacturing facilities, which are subject to various operating risks, including those beyond our control, such as the breakdown and failure of equipment or industrial accidents and severe weather conditions and natural disasters. Any significant malfunction or breakdown of our machinery may entail significant repair and maintenance costs and cause delays in our operations. If we are unable to repair malfunctioning machinery in a timely manner or at all, our operations may need to be suspended until we procure machinery to replace the same. In addition, we may be required to carry out planned shutdowns of our facilities for maintenance, statutory inspections and testing, or may shut down certain facilities for capacity expansion and equipment upgrades. We also face significant down-time for several machines due to seasonal nature of our sugar business. We may also face protests from local citizens at our existing facilities or while setting up new facilities, which may delay or halt our operations. While some of our segments have different production areas, we have various machines linking one product to the other. For example, our sugar manufacturing process produces bagasse which is continuously moved from the sugar mills to the co-generation boiler and similarly, molasses, also a residue from the sugar manufacturing process is transferred to various tanks to be used in the distillery section. Further, several of the raw materials that we require, are perishable products and consequently any malfunction or break-down of our machinery or equipment resulting in the slowdown or stoppage of our operations may adversely affect the quality of such raw materials.

Although we have not experienced any significant disruptions at our manufacturing facilities in the past, we cannot assure you that there will not be any disruptions in our operations in the future. Our inability to effectively respond to such events and rectify any disruption, in a timely manner and at an acceptable cost, could lead to the slowdown or shut-down of our operations or the under-utilization of our manufacturing facilities, which in turn may have an adverse effect on our business, results of operations and financial condition.



**38. A shortage or non-availability of electricity, fuel or water may adversely affect our manufacturing operations and have an adverse effect on our business, results of operations and financial condition.**

Our manufacturing operations require a significant amount and continuous supply of electricity, fuel and water and any shortage or non-availability may adversely affect our operations. Though we have our own co-generation unit which provides us with captive power, during non-crushing seasons or otherwise, we may require to purchase coal or bagasse for use in our co-generation unit. Any inability to procure the same may result in shortage of power. The production process of certain products, as well as the storage of certain raw materials and products in controlled environments requires significant power. We currently source our water requirements from existing jack-wells and from canal water of the Hiddkal Dam for which we have obtained permission from the State authorities. However, if such permission is revoked or there is a water shortage we may have to resort to expensive means of procuring water like tankers.

Further, although we have diesel generators to meet exigencies at our facility and we have our own diesel pump obtained from the Indian Oil Corporation (IOC), we cannot assure you that our facilities will be operational during power failures. Any failure on our part to obtain alternate sources of electricity, fuel or water, in a timely fashion, and at an acceptable cost, may have an adverse effect on our business, results of operations and financial condition.

**39. Two of our independent Directors and one of our Promoters has been / are associated with the Belagavi District Central Co operative Bank Limited (“BDCC Bank”), which is our main banker. Any past / current association of our independent directors and our Promoters with our banker could result in a conflict of interest and may affect our ability to raise funds in the future.**

Two of our Independent Directors, Mr. Shivanand Tubachi and Mr. Basavaraj Hagaragi were employees in the Belagavi District Central Co operative Bank Limited (“**BDCC Bank**”) till 2011 & 2013, respectively. Also, Mr. Basavaraj Hagaragi, having served as Branch Manager, is associated with the bank in an advisory capacity. Currently, our Company has a total sanctioned loan from BDCC Bank of ₹ 13,041 lakhs (including term loan and working capital loan) as on March 31, 2019. Further still, our Promoter, Mr. Ramesh Katti, is the elected Chairman & Non – Executive Director of the BDCC Bank in an honorary capacity. However, he is not on the Board of the Issuer Company and also not actively involved in the day-to-day business of the Issuer Company.

Though the Company has maintained professional terms with the bank and all our loan transactions are on arms length basis, there can be no assurance that these connections would not affect our future business relations with such banks.

**40. An ad interim stay order has been passed against our Company preventing our Company from utilising the label “Our Choice” on its products**

An Ordinary Suit dated May 29, 2014 was filed by M/s Allied Blenders and Distilleries Private Limited before the Hon’ble Delhi High Court for permanent injunction debarring (i) Sri Venkateshwara Distilleries and (ii) the Company from use of the label "Our Choice" wherein M/s Allied Blenders and Distilleries Private Limited had prayed for a decree of permanent injunction in respect of infringement of copyright, infringement of design and for restraining passing off along with leave to reserve the right under Order II, Rule 2 of Code of Civil Procedure, 1908. In pursuance of the above mentioned prayer, an ex-parte ad interim stay order was passed by the Delhi High Court as on May 29, 2014 in the favour of M/s Allied Blenders and Distilleries Private Limited. Consequently, an application under Order 39, Rule 4 of Code of Civil Procedure, 1908 was filed by the Company to vacate the ex parte ad interim stay order passed by the Court May 29, 2014. In the interim, the Company adopted a new mark “Your’s Choice” and the Hon’ble Delhi High Court passed a further Order dated September 27, 2017 under which the Company was enjoined from using the mark “Your’s Choice”. Further, on February 23, 2018 the aforesaid Ordinary Suit was converted from no. 1769 of 2014 to CS (Comm) 646/2018. This matter is currently pending before the Hon’ble Delhi High Court.

However, the aforesaid proceedings are costly to defend and can materially affect the financial condition of the Company, even if the Company is successful in defending such proceedings or effectively redress such complaints. Further, if the Company fails to defend the aforesaid proceedings, the Company shall not be able to use the label "Our Choice" or “Your’s Choice”. Even if the Company is successful in defending or settling them, our reputation could be materially harmed. The same will affect the financial condition and business operations of the Company. For further details, see the section entitled “*Outstanding Litigation and Material Developments*” on page no. 277 of this Red Herring Prospectus.

**41. *We have a large shareholder base including promoter / promoter group and public category and we do not have 100% shares in demat form, which are held by a large number of farmers.***

As on date of this Red Herring Prospectus, our Company is in compliance with Regulation 31 (2) of the SEBI Listing Regulations and Clause 6 (d) of SEBI Circular no. CIR/CFD/CMD/13/2015 dated November 30, 2015, i.e. 100% of the Shareholding of our Promoters & Promoter Group and atleast 50% of the Public shareholding are in Demat form. However, the above constitutes, only 68.09% of the total post-Offer shareholding of the Company and the remaining 31.91% post-Offer shareholding will still be held in the physical format.

As per MCA notification dated September 10, 2018, shares of unlisted public companies held by shareholders cannot be transferred unless the same are in demat form after October 02, 2018. Further, and as per Regulation 40 of SEBI Listing Regulations, as amended, and subsequent press release, shares of listed companies cannot be transferred in physical form after April 01, 2019. Though the Company has obtained connectivity from NSDL and CDSL for dematerialising the shares, and also are actively assisting all shareholders in the demat process, if the shares, other than as mentioned above are not converted to demat form, the such shareholders holding shares in physical form may not be able to trade / transfer their shares, thus locking their investment, until the demat of such shares is done.

**42. *Non-compliance with and changes in, safety, health and environmental laws and other applicable regulations, may adversely affect our business, results of operations and financial condition.***

We are subject to a broad range of safety, health, environmental, labour, workplace and related laws and regulations in the jurisdictions in which we operate, which impose controls on the disposal and storage of raw materials, noise emissions, air and water discharges; on the storage, handling, discharge and disposal of chemicals, employee exposure to hazardous substances and other aspects of our operations. For example, laws in India limit the amount of hazardous and pollutant discharge that our manufacturing facilities may release into the air and water. The discharge of substances that are chemical in nature or of other hazardous substances into the air, soil or water beyond such limits may cause us to be liable to regulatory bodies and incur costs to remedy the damage caused by such discharges. Further, any accidents at our facilities may result in personal injury or loss of life of our employees, contract labourers or other people, substantial damage to or destruction of property and equipment resulting in the suspension of operations. Any of the foregoing could subject us to litigation, which may increase our expenses in the event we are found liable, and could adversely affect our reputation. Additionally, the government or the relevant regulatory bodies may require us to shut down our facilities, which in turn could lead to product shortages that delay or prevent us from fulfilling our obligations to customers.

The adoption of stricter health and safety laws and regulations, stricter interpretations of existing laws, increased governmental enforcement of laws or other developments in the future may require that we make additional capital expenditures, incur additional expenses or take other actions in order to remain compliant and maintain our current operations. Complying with, and changes in, these laws and regulations or terms of approval may increase our compliance costs and adversely affect our business, prospects, results of operations and financial condition.

We are also subject to the laws and regulations governing relationships with employees in such areas as minimum wage and maximum working hours, overtime, working conditions, hiring and termination of employees, contract labour and work permits. There is a risk that we may inadvertently fail to comply with such regulations, which could lead to enforced shutdowns and other sanctions imposed by the relevant authorities, as well as the withholding or delay or non-renewal in receipt of regulatory approvals for our products. We cannot assure you that we will not be involved in future litigation or other proceedings, or be held liable in any litigation or proceedings including in relation to safety, health and environmental matters, the costs of which may be significant.

**43. *Changes in latest technology machinery/ requirement of machinery based on business opportunity may adversely affect our Company's results of operations and its financial condition.***

Modernization and technology up gradation is essential to reduce costs and increase the output. Changes in technology may render our current technologies obsolete or require us to make substantial capital investments. However, our existing manufacturing units have machineries with latest technology and we strive to keep our technology, equipments and machinery in line with the latest technological standards. But in future we may be required to implement new technology or upgrade the machineries and other equipments employed by us. Further, the costs in upgrading our technology and modernizing the plant and machineries may be significant which could substantially affect our finances and operations.

Further in case of machinery requirement based on business opportunity/ latest technology machinery, we will have to incur huge expenditure which may adversely affect our Company's results of operations and its financial condition. Also inability to up-grade our technology and key infrastructure on timely basis may hamper our operations and financial conditions.

**44. *We operate in five business segments and our inability to manage our diversified operations may have an adverse effect on our business, results of operations and financial condition.***

We operate in five business segments under our own Company: Sugar, Co-generation, Distillery, IML and Vinegar. Though these business segments are inter-connected, our management requires considerable expertise and skill to manage and allocate an appropriate amount of time, attention and other resources to each segment. Operating such multiple segments also makes forecasting future revenue and operating results difficult, which may impair our operations and your ability to assess our prospects. In addition, our cost controls, internal controls, and accounting and reporting systems must be integrated and upgraded on a continual basis to support our segments. In order to manage and integrate our segments effectively, we will be required to, among other things, stay abreast with key developments in each geography in which we operate, implement and continue to improve our operational, financial and management systems, develop the management skills of our managers and continue to train, motivate and manage our employees. If we are unable to manage our segmental operations, our business, results of operations and financial condition may be adversely affected.

**45. *Our management will have broad discretion in how we apply the Net Proceeds, including interim use of the Net Proceeds, and there is no assurance that the objects of the Issue will be achieved within the time frame expected or at all, or that the deployment of the Net Proceeds in the manner intended by us will result in any increase in the value of your investment. Further, the funding plan has not been appraised by any bank or financial institution.***

Our Company intends to use the Net Proceeds from the Fresh Issue for the purposes described in the section entitled "*Objects of the Offer*" on page no. 102 of this Red Herring Prospectus. Subject to this section, our management will have broad discretion to use the Net Proceeds from the Fresh Issue, and investors will be relying on the judgment of our management regarding the application of the Net Proceeds from the Fresh Issue. The funding plans are in accordance with our own estimates and have not been appraised by any bank, financial institution or any other external agency. Our Company may have to revise its management estimates from time to time on account of various factors beyond its control, such as market conditions, competitive environment and consequently its requirements may change. Additionally, various risks and uncertainties, including those set forth in this section may limit or delay our efforts to use the Net Proceeds to achieve profitable growth in its business. Our Board will have significant flexibility in temporarily investing the Net Proceeds of the Fresh Issue. Accordingly, the use of the Net Proceeds for purposes identified by our management may not result in actual growth of its business, increased profitability or an increase in the value of your investment.

**46. *Our Company will not receive any proceeds from the Offer for Sale portion.***

This Offer comprises of an offer for sale of upto 70,00,000 Equity Shares by our various shareholders including some Promoters, Promoter Group and some public shareholders. For details of the person who have offered their shares in this Offer, please refer "*Annexure – A*" on page no. 367 of this Red Herring Prospectus. The proceeds from the Offer pertaining to the above sale shares will be paid to the aforesaid persons in proportion of the Equity Shares offered by them in the Offer and our Company will not receive any proceeds from the portion of the Offer for Sale. For further details, please refer the chapter titled "*Objects of the Offer*" on page no. 102 of the Red Herring Prospectus.

**47. *There can be no assurance that we will be successful in planning and executing our business strategies or sustain and manage our growth, which may adversely affect our business, results of operations, financial condition and cash flows.***

Our growth strategy includes expanding our existing IML business in the Bellad Bagewadi region by offering more products. Currently we sell whisky under our brands 'VSL Deluxe Whisky'. We are in the process of introducing other liquors like Rum, Vodka and Gin under these brand names. We cannot assure you that these new products will be accepted by our existing whisky customers or by new customer base that we intend to target. Also, any failure to penetrate the market with these new IML products may lead to higher inventory and increased costs resulting in adverse gaps in our working capital gap.

Further, our Company has recently purchased land at Navage Village, Belgaum, Karnataka, details of which are mentioned under the section “*Our Business – Properties*” on page no. 151 of this Red Herring Prospectus. This land has been purchased by our Company considering that the area has good sugarcane growth. Our Company may in future set-up an additional unit for sugar manufacture and other allied products. However, our Company has currently not yet finalised any concrete plans and are still at an evaluation stage. Delays if any, in finalising these plans as well as inability to acquire additional lands (if required) for a concrete project could affect our results of operations and financial conditions in the future.

Our ability to sustain and manage our growth depends significantly upon our ability to manage key issues such as selecting, recruiting, training and retaining personnel, locating and securing properties for our future expansions, maintaining effective risk management policies, continuing to offer products of a consistent quality, maintaining and expanding our customer base, developing and maintaining technical infrastructure and systems, ensuring a high standard of customer service and maintaining our current level of profitability. Failure to do any of the above may result in slower growth, loss of business, erosion of customer service quality, diversion of management resources, significant costs and increase in employee attrition rates, any of which could adversely affect our business, results of operations, financial condition and cash flows.

**48. *Our financing agreements contain covenants that limit our flexibility in operating our business. Our inability to meet our obligations, including financial and other covenants under our debt financing arrangements could adversely affect our business, results of operations and financial condition.***

As of March 31, 2019, our total outstanding indebtedness was ₹ 33,879.42 lakhs (including current maturities of long term debt). Our ability to meet our debt service obligations and repay our outstanding borrowings will depend primarily on the cash generated by our businesses. Further, our financing agreements contain certain restrictive covenants that limit our ability to undertake certain types of transactions, any of which could adversely affect our business and financial condition. We are required to obtain prior approval from our lenders for, among other things:

- alteration of the capital structure of our Company in any manner;
- undertaking any term loans borrowings;
- making changes to our management set up;
- making any change in ownership and shareholding pattern, including effecting any change in our actual and beneficial ownership or control, of our Company;
- making any investment in group companies, joint ventures or associates;
- effecting any amalgamation, merger, reconstruction, takeover or consolidation in relation to our Company;
- amending the memorandum and articles of association of our Company;
- concluding any fresh borrowing arrangements, either secured or unsecured, with any other lender;
- creation of further charge, lien or encumbrance on assets hypothecated with our lenders;
- effecting any material change in the management of our business or our operating structure;
- undertaking new projects or implementing any scheme of expansion or acquiring fixed assets;
- making any investment by way of subscription to share capital of, and loans, deposits or advances to, any other entity (including our group companies and associate companies);
- undertaking guarantee obligations on behalf of any other lender or any third party;
- declaring dividends; and
- effecting any repayment of loans and deposits and discharging other liabilities except those shown in the fund flow statements submitted to our lenders from time to time.

We are required to obtain the required consents of the lenders under our financing agreements before undertaking these significant corporate actions. We cannot assure you that the lenders will grant the required approvals in a timely manner, or at all. The time required to secure consents may hinder us from taking advantage of a dynamic market environment. In addition to the restrictions listed above, we are required to maintain certain financial ratios under our financing agreements. These financial ratios and the restrictive provisions could limit our flexibility to engage in certain business transactions or activities.

Additionally, our financing agreements are secured by our movable, immovable or intangible assets (whether existing or future), goods and work-in-progress (whether existing or future) and by personal guarantees of our Promoters. Such financing agreements enable the lenders to cancel any outstanding commitments, accelerate the repayment, exercise cross default provisions and enforce their security interests on the occurrence of events of default such as a breach of financial covenants, failure to obtain the proper consents, failure to perfect security as

specified and such other covenants that are not cured. It is possible that we may not have sufficient funds upon such an acceleration of our financial obligations to pay the principal amount and interest in full. Further, if we are forced to issue additional equity to the lenders, ownership interest of the existing shareholders in our Company will be diluted. It is also possible that future financing agreements may contain similar or more onerous covenants and may also result in higher interest cost. If any of these events were to occur, our business, results of operations and financial condition may be adversely affected.

**49. *We face significant competition in our business from Indian sugar manufacturers, which may adversely affect our profitability.***

The sugar industry is highly competitive. Domestically, we compete with numerous small to medium size producers. Despite increased consolidation, the Indian sugar industry remains highly fragmented. Our major competitors in India are sugar mills based in the southern Indian state of Karnataka and nearby states including competition from the sugar mills based in the Indian state of Maharashtra. Further, excess sugar stocks may be dumped by competitors from other states into the northern India region markets, leading to excess supply and price drop.

We also face substantial competition from potential competitors who may seek to manufacture the same or similar products as us in the particular area or competitors who are already manufacturing, distributing and selling products which we deal in. None of our registrations are granted exclusively to us and our competitors are free to seek registration for the products for which we hold registrations. In the event that other players in our region obtain registration for the distillery or IML or vinegar products that we have registered for, it may adversely affect our sales and margin in relation to such products.

Additionally, we compete with existing sugar manufacturing units on the basis of portfolio of our by-product offerings, product traits, including quality consistency, lower rejection ratio, as well as based on price, reputation, customer service and customer convenience. Some of our competitors may be large multinational companies that have significantly greater resources and access than those available to us. If we are unable to compete effectively, including in terms of pricing or providing quality products, our market share may decline, which could have a material adverse effect on our results of operations and cash flows.

**50. *We are susceptible to product liability claims that may not be covered by insurance and may subject us to substantial expenditure thereby adversely affecting our reputation and if the claim is successful, could require us to pay substantial amounts.***

We face the risk of loss resulting from, and the adverse publicity associated with, product liability lawsuits, whether or not such claims are valid. We may be subject to claims resulting from our manufacturing defects or negligence in storage, packaging or handling which may lead to the deterioration of our products including sugar, IML, vinegar, ENA or other distillery products. Even unsuccessful product liability claims would likely require us to incur substantial expenses on litigation, divert management's time, adversely affect our goodwill and impair the marketability of our products.

We are liable for the quality of the products we manufacture, for the duration of their shelf life. Disputes over non-conformity of the products with prescribed quality standards or specifications including storage specifications are generally referred to independent testing laboratories. If any independent laboratory confirms that the products do not conform to the prescribed or agreed standards and specifications, we may be required to bear the expenses of replacing and testing such products, which could adversely affect our business, results of operations, cash flows and financial condition. Any proved defect in our products could also result in withdrawal of our license for manufacturing, storing and selling the products. Further, our business is dependent on the trust our customers have in the quality of our products. Any negative publicity regarding our Company, brand, or products or mishaps resulting from the use of our products, or any other unforeseen events could affect our reputation and our results from operations.

Further, we do not have any insurance coverage for product liability and if we are to take the same, it may result in additional expense. From time to time, the sugar industry has experienced difficulty in obtaining desired product liability insurance coverage. If any product liability claim not covered by insurance were sustained against us, it could adversely affect our business, financial condition, results of operations and cash flows.



**51. Our Company may incur penalties in respect of non – compliance with the provisions of the Companies Act, 2013.**

Our Company in the past, was in non – compliance of certain provisions of the Companies Act, 2013 during the period from April 2014 to December 2017. These violations were in relation to the non – filing of the concerned RoC form for the appointment of the Chief Financial Officer (“CFO”). Our Company has filed a “Condonation of Delay” with the RoC on December 17, 2017 for such non – compliance.

There can be no assurance that the non-compliances for which we have filed a Condonation of Delay will be condoned in a timely manner or at all or that our Company will not be subjected to penalty or liabilities with respect to non-compliances under the Companies Act. The imposition of any liability on our Company on account of such non-compliances, including their re-occurrence, could adversely affect our business and reputation.

**52. Changing laws, rules and regulations and legal uncertainties, including adverse application of tax laws, may adversely affect our business, prospects and results of operations.**

The regulatory and policy environment in which we operate is evolving and subject to change. Such changes may adversely affect our business, results of operations and prospects, to the extent that we are unable to suitably respond to and comply with any such changes in applicable law and policy. GST has been implemented with effect from July 1, 2017 and has replaced the indirect taxes on goods and services such as central excise duty, service tax, central sales tax, state VAT and surcharge currently being collected by the central and state governments. The GST is expected to increase tax incidence and administrative compliance. Given the limited availability of information in the public domain concerning the GST, we are unable to provide any assurance as to the tax regime following implementation of the GST. The implementation of this new structure may be affected by any disagreement between certain state Governments, which could create uncertainty. Any such future amendments may affect our overall tax efficiency, and may result in significant additional taxes becoming payable.

We may also incur increased costs and other burdens relating to compliance with new requirements under the GST regime, which may also require significant management time and other resources, and any failure to comply may adversely affect our business, results of operations and prospects.

**53. Any infringement of our registered corporate logo  or failure to protect it may adversely affect our business.**

Our corporate logo  is registered with the Registrar of Trademarks under Trademark No. 215286 in Class 30 and Trademark No. 2152827 in Class 33. Given the nature of our business, we cannot assure you that our corporate logo will not be infringed by our competitors and third parties, which may expose us to expensive legal proceedings and the same can have an adverse effect on our business, results of operations and financial condition. Our Company also may not be able to take timely steps to curb such infringement or adequately protect our intellectual property data, trade secrets or proprietary technology from infringement by competitors. Any litigation undertaken to protect our intellectual property could be time consuming and costly and the outcome thereof cannot be guaranteed. Such infringement may also lead to our Company losing business to such competitors and might adversely affect our goodwill. For further details please refer to section titled “Government and Other Approvals” beginning on page no. 300 of this Red Herring Prospectus.

**54. Inability to comply with EPCG related requirements may have an adverse effect on our business, financial position, profitability and results of operations.**

The Government of India has provided for various fiscal incentives including concessions on duty imports under the Export Promotion Capital Goods Scheme (“EPCG Scheme”). Our Company also enjoys certain incentives under the EPCG Scheme for our manufacturing facility. The EPCG Scheme allows imports at concession rates of customs duty and requires the importer to export a specified quantity of goods over a period of six/eight years and to maintain an average export performance per year. Non-fulfilment of such obligations may result in confiscation of capital goods imported under EPCG Scheme and other penalties as set out in the EPCG Scheme. The export obligation of our Company under the EPCG Scheme as on March 31, 2019 was ₹ 289.99 lakhs. There can be no assurance that we would be able to meet the export obligations at all times in the future and any such failure could expose us to penal liabilities. In the event we are in default of the EPCG Scheme and the incentives provided therein are withdrawn by the Government of India, it could have a material adverse effect on our business, financial position, profitability and results of operation. Further, we may be penalized for our failure to comply with such export obligations in a timely manner or at all.



For further information please refer to the section titled “Government and Other Approvals” on page no. 300 of this Red Herring Prospectus.

**55. Our insurance coverage may not be sufficient or may not adequately protect us against any or all hazards, which may adversely affect our business, results of operations and financial condition.**

Legal proceedings or other actions may be initiated against us or any of our employees for acts and conduct of our employees which may occur due to various reasons including misconduct with customers. In the event of personal injuries, damage or other accidents suffered by our employees or our customers or other people, we could face claims alleging that we were negligent, provided inadequate training or supervision or be otherwise liable for the injuries. Our principal types of insurance coverage include motor vehicle insurance, cash in transit insurance, fire, burglary and special perils insurance, group mediclaim and personal accident policy and workmen’s compensation policy.

While we believe that the insurance coverage which we maintain would be reasonably adequate to cover the normal risks associated with the operation of our businesses, we cannot assure you that any claim under the insurance policies maintained by us will be honoured fully, in part or on time, or that we have taken out sufficient insurance to cover all our losses. In addition, our insurance coverage expires from time to time. We apply for the renewal of our insurance coverage in the normal course of our business, but we cannot assure you that such renewals will be granted in a timely manner, at acceptable cost or at all. To the extent that we suffer loss or damage, or successful assertion of one or more large claims against us for events for which we are not insured, or for which we did not obtain or maintain insurance, or which is not covered by insurance which exceeds our insurance coverage or where our insurance claims are rejected, the loss would have to be borne by us and our results of operations, financial performance and cash flows could be adversely affected. For further details on our insurance arrangements, see “Our Business – Insurance” on page no. 153 of this Red Herring Prospectus.

**56. Some of our Group Entities have incurred losses during the last three financial years and / or have not commenced commercial operations since incorporation and have a negative net worth in one of the three immediately preceding financial years as disclosed.**

One of our Group Companies had incurred losses during the last three financial years, details of which are as under:

(₹ in lakhs)

Name of the Company	PAT as at March 31,		
	2018	2017	2016
U R Agrofresh Private Limited	15.52	4.03	(13.99)

Further, two of our Group Companies, namely, Vishwaraj Infrastructure Private Limited (VIPL) and UK27 Hospitality Private Limited (UK27) have been incorporated on November 11, 2009 and August 02, 2013, respectively. However, these companies have not yet commenced their commercial operations till March 31, 2018. Further still, VIPL had a negative net worth in one of the immediately preceding three years as disclosed in the chapter “Our Group Companies” on page no. 197 of this Red Herring Prospectus.

**57. One of our Group Company is currently ACTIVE Non-Compliant for failure to file the Form INC - 22A until the prescribed time.**

One of our Group Companies, UK27 Hospitality Services (India) Limited (UK27) has not filed the Form INC - 22A (ACTIVE) till the date of this Red Herring Prospectus. Form INC – 22A has been introduced by the MCA for the address validation of all registered companies under the Companies Act, 2013. This form was introduced by the MCA February 21, 2019 and the extended due date for filing this form was June 15, 2019. However in the mean time, the Company Secretary of the UK27 resigned on March 31, 2019 and the company is yet to appoint another Company Secretary and due to the same the Company is unable to file Form INC – 22A till date. Pursuant to the failure to file the ACTIVE form, the company will not be able to effect any changes in its Authorised Capital, Paid-up Capital, Directors and Registered Office and also will not be able to enter into merger or amalgamation transactions. Further, besides the stipulated monetary penalty, the company could be liable to regulatory action by the RoC and NCLT. Any adverse action against the company could affect the reputation of our Promoters / Directors who are directors in UK27.

**58. *In addition to normal remuneration, other benefits and reimbursement of expenses some of our Directors (including our Promoter) and Key Management Personnel are interested in our Company to the extent of their shareholding and dividend entitlement in our Company.***

Some of our Directors (including our Promoter) and Key Management Personnel are interested in our Company to the extent of their shareholding and dividend entitlement in our Company, in addition to normal remuneration or benefits and reimbursement of expenses. We cannot assure you that our Directors or our Key Management Personnel would always exercise their rights as Shareholders to the benefit and best interest of our Company. As a result, our Directors will continue to exercise significant control over our Company, including being able to control the composition of our board of directors and determine decisions requiring simple or special majority voting, and our other Shareholders may be unable to affect the outcome of such voting. Our Directors may take or block actions with respect to our business, which may conflict with our best interests or the interests of other minority Shareholders, such as actions with respect to future capital raising or acquisitions. We cannot assure you that our Directors will always act to resolve any conflicts of interest in our favour, thereby adversely affecting our business and results of operations and prospects.

**59. *Three of our Promoters are politicians. One is an MLA in the State Legislature of Karnataka and the other two are a Member of Zilla Panchayat. Any adverse incidence in their political lives may affect the business growth of our Company and/or the price of our scrip.***

Three of our Promoters i.e. Mr. Umesh Katti, Mr. Kush Katti and Mr. Nikhil Katti are politicians. Mr. Umesh Katti is a M.L.A. of the Karnataka Legislature and has been elected eight times from Hukkeri legislative assembly constituency. He was a Cabinet Minister in the Government of Karnataka between 1996-1999 holding the portfolio of the Sugar Ministry and later Public Works. He has held various positions in the Government of Karnataka over the years being Minister-in-Charge of Agriculture, Belgaum District, Minister-in-Charge of Prisons, Horticulture etc. His political career spans over three decades and he is currently a Member of the Bharatiya Janata Party (BJP) in the State of Karnataka. Mr. Nikhil Katti, son of Mr. Umesh Katti has actively participated in local politics and socio-economic welfare activities in his constituency. He is currently been elected as the member of the Zilla Panchayat – Ammanagi, Chikodi Taluka. Mr. Kush Katti has actively participated in local politics and socio-economic welfare activities in his constituency. He is currently been elected as the member of the Zilla Panchayat – Nagaramunnoli, Hukkeri Taluka. The father of Mr. Kush Katti i.e. Mr. Ramesh Katti, was also a politician and was an MLC during the period 1972-1978 and a Member of Parliament (Lok Sabha) during 2009-2014.

Due to the political affiliations of our Promoters, Mr. Umesh Katti, Mr. Nikhil Katti and Mr. Kush Katti the investors may perceive that any adverse incidences in their political career such as loss of power by the political party with whom they are affiliated, loss of cabinet seat, their political rivals or parties coming to power, defeat in elections and such other political reasons, may affect the business growth of our Company and/or the price of our scrip.

**60. *The requirements of being a listed company may strain our resources.***

We are not a listed Company and have not, historically, been subjected to the increased scrutiny of our affairs by shareholders, regulators and the public at large that is associated with being a listed company. As a listed company, we will incur significant legal, accounting, corporate governance and other expenses that we did not incur as an unlisted company. We will be subject to the listing agreements with the Stock Exchanges and compliances of SEBI Listing Regulations which will require us to file audited annual and unaudited semi-annual and limited review reports with respect to our business and financial condition. If we experience any delays, we may fail to satisfy our reporting obligations and/or we may not be able to readily determine and accordingly report any changes in our results of operations as promptly as other listed companies which may adversely affect the financial position of the Company.

As a listed company, we will need to maintain and improve the effectiveness of our disclosure controls and procedures and internal control over financial reporting, including keeping adequate records of daily transactions to support the existence of effective disclosure controls and procedures, internal control over financial reporting and additional compliance requirements under the Companies Act, 2013. In order to maintain and improve the effectiveness of our disclosure controls and procedures and internal control over financial reporting, significant resources and management oversight will be required. As a result, management's attention may be diverted from other business concerns, which could adversely affect our business, prospects, financial condition and results of operations. In addition, we may need to hire additional legal and accounting staff with appropriate listed company experience and technical accounting knowledge and we cannot assure you that we will be able to do so in a timely manner.

## RISKS RELATING TO OUR EQUITY SHARES

- 61. *The Equity Shares issued pursuant to the Issue may not be listed on the Stock Exchange in a timely manner, or at all, and any trading closures at the Stock Exchange may adversely affect the trading price of our Equity Shares.***

In accordance with Indian law and practice, permission for listing and trading of the Equity Shares issued pursuant to the Offer will not be granted until after the Equity Shares have been issued and allotted. Approval for listing and trading will require all relevant documents authorising the issuing of Equity Shares to be submitted and there could therefore be a failure or delay in listing the Equity Shares on the Stock Exchanges. Any failure or delay in obtaining such approval would restrict your ability to dispose of your Equity Shares.

- 62. *The Equity Shares have never been publicly traded and the Issue may not result in an active or liquid market for the Equity Shares.***

Prior to the Offer, there has been no public market for the Equity Shares and an active public market for the Equity Shares may not develop or be sustained after the Offer. Listing and quotation does not guarantee that a trading market for the Equity Shares will develop or, if a market does develop, the liquidity of that market for the Equity Shares. Although we currently intend that the Equity Shares will remain listed on the Stock Exchanges, there is no guarantee of the continued listing of the Equity Shares. Failure to maintain our listing on the Stock Exchanges or other securities markets could adversely affect the market value of the Equity Shares.

The Offer Price of the Equity Shares is proposed to be determined following a book-building process by agreement between the BRLM and the Company on the Pricing Date and may not be indicative of prices that will prevail in the trading market. You may not be able to resell your Equity Shares at a price that is attractive to you.

- 63. *The price of the Equity Shares may be volatile, which could result in substantial losses for investors acquiring the Equity Shares in the Offer.***

The market price of the Equity Shares may be volatile and could fluctuate significantly and rapidly in response to, among others, the following factors, some of which are beyond our control:

- volatility in the Indian and global securities market or in the value of the Rupee relative to the U.S. Dollar, the Euro and other foreign currencies;
- our profitability and performance;
- changes in financial analysts' estimates of our performance or recommendations;
- perceptions about our future performance or the performance of Indian companies in general;
- performance of our competitors and the perception in the market about investments in the sugar sector;
- adverse media reports about us or the Indian sugar sector;
- significant developments in India's economic liberalisation and deregulation policies;
- significant developments in India's fiscal and environmental regulations;
- economic developments in India and in other countries; and
- any other political or economic factors.

These fluctuations may be exaggerated if the trading volume of the Equity Shares is low. Volatility in the price of the Equity Shares may be unrelated or disproportionate to our results of operations. It may be difficult to assess our performance against either domestic or international benchmarks.

- 64. *Investors can be subject to Indian taxes arising out of capital gains on the sale of the Equity Shares. Recently, the Finance Act, 2018 levies taxes on such long-term capital gains exceeding ₹ 100,000 arising from sale of Equity Shares on or after April 1, 2018, while continuing to exempt the unrealized capital gains earned up to January 31, 2018 on such Equity Shares.***

Under current Indian tax laws, capital gains arising from the sale of Equity Shares in an Indian Company are generally taxable in India. However, the Finance Act, 2018, has now levied taxes on such long-term capital gains exceeding ₹ 100,000 arising from sale of Equity Shares on or after April 1, 2018, while continuing to exempt the unrealized capital gains earned up to January 31, 2018 on such Equity Shares. Accordingly, you may be subject to payment of long-term capital gains tax in India, in addition to payment of STT, on the sale of any Equity Shares

held for more than 12 months. STT will be levied on and collected by a domestic stock exchange on which the Equity Shares are sold.

Further, any gain realized on the sale of listed equity shares held for a period of 12 months or less will be subject to short term capital gains tax in India. Capital gains arising from the sale of the Equity Shares will be exempt from taxation in India in cases where the exemption from taxation in India is provided under a treaty between India and the country of which the seller is resident. Generally, Indian tax treaties do not limit India's ability to impose tax on capital gains. As a result, residents of other countries may be liable for tax in India as well as in their own jurisdiction on a gain upon the sale of the Equity Shares.

**65. *Future issuances or sales of the Equity Shares could dilute your shareholding and significantly affect the trading price of the Equity Shares.***

The future issuance of Equity Shares by us, the disposal of Equity Shares by any of our major shareholders or the perception that such issuance or sales may occur, may lead to the dilution of your shareholding in the Company or significantly affect the trading price of the Equity Shares. These sales could also impair our ability to raise additional capital through the sale of our equity securities in the future.

Furthermore, under the Securities Contract (Regulation) Rules, 1957, as amended ("SCRR"), listed companies are required to maintain public shareholding of at least 25% of their issued share capital. Failure to comply with the minimum public shareholding provision would require a listed company to delist its shares and may result in penal action being taken against the listed company pursuant to the SEBI Act. This may require us to issue additional Equity Shares or require our Promoters or Promoter Group to sell their Equity Shares, which may adversely affect our trading price.

**66. *Our ability to pay dividends in the future will depend upon future earnings, financial condition, cash flows, working capital requirements, capital expenditures and restrictive covenants in our financing arrangements.***

We are primarily a sugar and allied products manufacturing company. Our future ability to pay dividends will depend on the earnings, financial condition and capital requirements of our Company. Dividends distributed by us will attract dividend distribution tax at rates applicable from time to time. We cannot assure you that we will generate sufficient income to cover our operating expenses and pay dividends to our shareholders, or at all.

Our business is capital intensive and we may plan to make additional capital expenditures for expansion of our sugar manufacturing facility, power generation and other allied product facilities. Our ability to pay dividends could also be restricted under certain financing arrangements that we may enter into. We may be unable to pay dividends in the near or medium term, and our future dividend policy will depend on our capital requirements and financing arrangements for the expansion projects, working capital requirement, financial condition and results of operations.

## **EXTERNAL RISK FACTORS**

**67. *Our business is heavily dependent on the performance of, and the prevailing conditions affecting, the Sugar Industry in Karnataka and in India generally.***

Our manufacturing unit is located in Bellad Bagewadi near Belgaum, Karnataka. For details of our products and other details, please see the section entitled "*Our Business*" on page no. 130 of this Red Herring Prospectus. As a result, our business, financial condition and results of operations have been and will continue to be heavily dependent on the performance of, and the prevailing conditions affecting, the sugar market in Belgaum, Karnataka and in India generally.

The sugar market in Belgaum and in India generally may be affected by various factors outside our control, including, among others:

- prevailing local economic, income and demographic conditions;
- availability of consumer financing (interest rates and eligibility criteria for loans);
- availability of and demand for sugar comparable to those we manufacture;
- changes in governmental policies relating to sugarcane price and sugar price;
- changes in governmental policies relating to IML and Distillery products;
- changes in applicable regulatory schemes; and

- the cyclical nature of demand for and supply of sugar.

These factors may result in fluctuations in sugar prices and the availability of sugarcane, which may negatively affect the demand for sugar and also related allied products. During times of crisis, market sentiment may be adversely affected, buyers may become cautious and sales or collections could be adversely affected which may have a material adverse effect on our financial condition and results of operations.

**68. *Recent global economic conditions have been unprecedented and challenging and continue to affect the Indian market, which may adversely affect our business, financial condition, results of operations and prospects.***

The Indian economy and its securities markets are influenced by economic developments and volatility in securities markets in other countries. Investors' reactions to developments in one country may have adverse effects on the market price of securities of companies located in other countries, including India. For instance, the economic downturn in the U.S. and several European countries during a part of Fiscal 2008 and 2009 adversely affected market prices in the global securities markets, including India. Negative economic developments, such as rising fiscal or trade deficits, or a default on national debt, in other emerging market countries may also affect investor confidence and cause increased volatility in Indian securities markets and indirectly affect the Indian economy in general.

Although economic conditions are different in each country, investors' reactions to developments in one country can have materially adverse effects on the securities of companies in other countries, including India. The Indian financial markets experienced the contagion effect of the volatility and turmoil in the global financial markets, which was evident from the sharp decline in the benchmark index of the S&P BSE SENSEX from its peak levels in early 2008 to the first quarter of 2009. Furthermore, as a consequence of the severe tightening of credit associated with that financial turmoil, many economies experienced periods of severe recession accompanied by a significant deterioration of consumer confidence and demand.

A loss of investor confidence in the financial systems of other emerging markets may cause increased volatility in Indian financial markets and the Indian economy in general. Any worldwide financial instability could also have a negative impact on the Indian economy, including the movement of exchange rates and interest rates in India. In June 2016, a majority of voters in the United Kingdom elected to withdraw from the European Union in a national referendum which has created significant uncertainty about the future relationship between the United Kingdom and the European Union, including with respect to the laws and regulations that will apply as the United Kingdom determines which European Union laws to replace or replicate in the event of a withdrawal. These developments, or the perception that any of them could occur, have had and may continue to have a material adverse effect on global economic conditions and the stability of global financial markets, and may significantly reduce global market liquidity and restrict the ability of key market participants to operate in certain financial markets. Any of these factors could depress economic activity and restrict our access to capital, which could have a material adverse effect on our business, financial condition and results of operations and reduce the price of our equity shares. Any financial disruption could have an adverse effect on our business, financial condition and results of operations as well as the price of our Equity Shares.

**69. *Political, economic or other factors beyond our control may have an adverse impact on our business, results of operations and prospects.***

The following external risks may have an adverse impact on our business, results of operations and prospects, should any of them materialise:

- the lingering effects of the global economic slowdown have generally dampened business confidence and made the credit markets more volatile, besides negatively impacting other industry players;
- increase in interest rates may adversely affect our access to capital and increase our borrowing costs, which may constrain our ability to grow our business and operate profitably;
- a downgrade of India's sovereign rating by domestic and international credit rating agencies may adversely affect our access to capital (domestically and internationally) and may increase our borrowing costs, which may constrain our ability to grow our business and operate profitably;
- a decline in India's foreign exchange reserves may affect liquidity and interest rates in the Indian economy as well as the valuation of the Indian Rupee, which may adversely affect our financial condition;
- political instability, resulting from a change in government or in economic and fiscal policies, may adversely affect economic conditions in India, which in turn may adversely affect the financial condition, business operations and future prospects of the business;



- civil unrest, acts of violence, terrorist attacks, regional conflicts or situations or war. If our operations are disrupted by any such agitation, particularly in locations where we have a significant concentration or presence, our business, results of operations and prospects could be adversely affected; and
- India has experienced natural calamities such as earthquakes, tsunamis, floods and drought in recent years. The extent and severity of these natural disasters determines their effect on the economy. If any of the offices, studios or other facilities were to be damaged as a result of an earthquake or other natural calamities, or if such events should otherwise impact the national or any regional economies, our business, results of operations and prospects may be adversely affected.

**70. We may be affected by competition law in India and any adverse application or interpretation of the Competition Act could adversely affect our business.**

The Competition Act, 2002, as amended (the “Competition Act”), regulates practices having an appreciable adverse effect on competition in the relevant market in India. Under the Competition Act, any formal or informal arrangement, understanding or action in concert, which causes or is likely to cause an appreciable adverse effect on competition is considered void and may result in the imposition of substantial monetary penalties. Further, any agreement among competitors which directly or indirectly involves the determination of purchase or sale prices, limits or controls production, supply, markets, technical development, investment or provision of services in any manner, shares the market or source of production or provision of services by way of allocation of geographical area, type of goods or services or number of customers in the relevant market or in any other similar way, or directly or indirectly results in bid-rigging or collusive bidding is presumed to have an appreciable adverse effect on competition. The Competition Act also prohibits abuse of a dominant position by any enterprise. If it is proved that the contravention committed by a company took place with the consent or connivance of or is attributable to any neglect on the part of, any director, manager, secretary or other officer of such company, that person shall be guilty of the contravention and may be liable to punishment.

These provisions require acquisitions of shares, voting rights, assets or control or mergers or amalgamations that cross the prescribed asset and turnover based thresholds to be mandatorily notified to and pre-approved by the Competition Commission of India (the “CCI”). Additionally, on May 11, 2011, the CCI issued the Competition Commission of India (Procedure in regard to the transaction of business relating to combinations) Regulations, 2011, which sets out the mechanism for implementation of the merger control regime in India. The Competition Act aims to, among others, prohibit all agreements and transactions which may have an appreciable adverse effect on competition in India. Further, the CCI has extra-territorial powers and can investigate any agreements, abusive conduct or combination occurring outside India if such agreement, conduct or combination has an appreciable adverse effect on competition in India. In the event that we enter into any agreements or transactions that are held to have an appreciable adverse effect on competition in the relevant market in India, the provisions of the Competition Act will be applicable. Any prohibition or substantial penalties levied under the Competition Act could materially and adversely affect our financial condition, cash flows and results of operations.

**PROMINENT NOTES**

1. Investors are free to contact the Book Running Lead Manager (BRLM) for any clarification, complaint or information pertaining to the Offer. The BRLM, our Company and the Selling Shareholders shall make all information available to the public and investors at large and no selective or additional information would be made available for a section of the investors in any manner whatsoever.
2. The Net Worth of our Company is ₹ 21,149.69 lakhs and the book value of each Equity Share was ₹ 61.20/- as of March 31, 2019 as per our Restated Financial Statements. For more information, please refer the Section titled “*Financial Information*” beginning on page no. 202 of this Red Herring Prospectus.
3. Public Offer of 1,00,00,000 Equity Shares for cash at price of ₹ [●] per share including a premium of ₹ [●] aggregating to ₹ [●]. The Offer will constitute 26.63% of the post-Issue paid-up Equity Share capital of our Company.
4. The average cost of acquisition of Equity Shares by our Promoters is:

Promoter	Average cost (₹) <sup>(2)</sup>
Mr. Umesh Katti	11.71
Mr. Ramesh Katti	9.30
Mrs. Sheela Katti	10.00

Mrs. Jayashree Katti	10.00
Mr. Nikhil Katti <sup>(1)</sup>	12.55
Mr. Lava Katti <sup>(1)</sup>	10.00
Mr. Kush Katti <sup>(1)</sup>	10.00
Mr. Sneha Nithin Dev	10.00

<sup>(1)</sup> Mr. Nikhil Katti, Mr. Lava Katti and Mr. Kush Katti are also the Selling Shareholders in this Offer.

<sup>(2)</sup> As certified by M/s. Gojanur & Co., Chartered Accountants by their certificate dated July 08, 2019.

5. Investors are advised to refer to the chapter titled “Basis for Offer Price” beginning on page no. 108 of this Red Herring Prospectus.
6. The details of transactions by our Company with our Group Companies are disclosed under “Annexure VI – Note 34 – Related Party Transactions” on page no. 238 of this Red Herring Prospectus.
7. There are no financing arrangements whereby the Promoter Group, the Directors of our Company and their relatives have financed the purchase by any other person of securities of our Company during the period of 6 (six) months immediately preceding the date of the Draft Red Herring Prospectus.
8. Our Company was incorporated as a public limited company under the Companies Act, 1956 in the name of Vishwanath Sugars Limited vide Certificate of Incorporation dated May 02, 1995 with the Registrar of Companies, Bangalore bearing Registration Number - 017730. Our Company was granted the Certificate of Commencement of Business by the RoC, Bangalore on December 21, 1999. The name of our Company was subsequently changed to Vishwanath Sugar and Steel Limited and a Fresh Certificate of Incorporation dated December 28, 2010 was issued by the Registrar of Companies, Bangalore. The name of our Company was further changed to Vishwaraj Sugar Industries Limited vide Certificate of Incorporation dated November 29, 2012 granted by the Registrar of Companies, Bangalore. (CIN No: U85110KA1995PLC017730).

## SECTION III – INTRODUCTION

### SUMMARY OF OUR INDUSTRY

#### INDIAN SUGAR INDUSTRY

India is at the cusp of another bumper sugar production phase recording, 32-33mnt (vs. consumption of 25-26mnt) in the coming season (Oct'18-Sep'19); this would be led by Uttar Pradesh (UP; higher acreage and yields), but partially offset by Maharashtra (lower yield). Despite record cane arrears, we believe farmers should continue to plant sugarcane crops given robust profitability (vs. alternatives) and assured offtake/cash flows.

The government continues to provide support to the industry through various measures including regulating the minimum selling price (MSP) of sugar, soft loans, export subsidies, cane price assistance, higher ethanol pricing and blending mandates. However, we believe ethanol is unlikely to break the cyclical nature of the sugar sector given its limited impact on sugar production.

After posting record sugar production of 32.2mnt in SS18 (+60% YoY; last peak of 28.3mnt in SS15), India is expected to produce another similar quantum (32-33mnt) in SS19, led by a) higher acreage and yield in UP (growing adoption of new 'early variety' sugarcane) and b) higher acreage in MH and Karnataka (good monsoon in 2017), offset by lower yields due to pest attacks/drought in key pockets of production. Even after assuming 5mnt of exports, India is likely to end with closing stock of 12mnt in Sep'19, almost 6-7 months' consumption). Moreover, considering the nature of the crop (long duration and sturdy, assured cash flows, adoption of the early variety of sugarcane) and robust profitability, we believe India should mostly have an excess supply scenario, except in case of severe drought or pest attacks. (Source: Sector Update – India Sugar; A New Saviour for The Sugar Industry?; JM Financial; October 2018)

India's centrifugal sugar (henceforth sugar) production in Marketing Year 2018/19 (Oct-Sept) is expected to rise 4.2 percent to a record 33.8 million metric tons (MMT). Uttar Pradesh will be the largest producer of sugar in India, for the third year in a row. A higher sugarcane production forecast of 415 MMT on 5.2 million hectares (MH) will contribute to the above estimates. Assuming normal market conditions, sugar mills will be encouraged to use up surplus inventory of up to 6 MMT. With incentives, this surplus could be exported, as out-year sugar supply will be 31 percent over consumption and normal stock requirements (34.4 MMT).

(Source: USDA Foreign Agricultural Services – Global Agricultural Information Network – India Sugar Annual 2018; [https://gain.fas.usda.gov/Recent%20GAIN%20Publications/Sugar%20Annual\\_New%20Delhi\\_India\\_4-10-2017.pdf](https://gain.fas.usda.gov/Recent%20GAIN%20Publications/Sugar%20Annual_New%20Delhi_India_4-10-2017.pdf))

#### Production

As on 15th December, 2018, 462 sugar mills were crushing sugarcane for the year 2018-19 and they have produced 70.52 lakh tons of sugar, i.e. 1.48 lakh tons (2.1%) higher than the sugar production on the corresponding date of previous sugar season, of 69.04 Lakh tons of sugar. Last year on the corresponding date, 476 mills were operating. (Source: [https://www.business-standard.com/article/news-cm/india-s-sugar-production-up-2-1-in-2018-19-sugar-season-so-far-118121900273\\_1.html](https://www.business-standard.com/article/news-cm/india-s-sugar-production-up-2-1-in-2018-19-sugar-season-so-far-118121900273_1.html))

Marketing Year 2018/19 centrifugal sugar (henceforth sugar) production is forecast to rise 4.3 percent to a record 33.8 MMT, which includes 560,000 metric tons (MT) of khandsari (a local type of low-recovery sugar prepared by open-pan evaporation) and 31.1 MMT of milled sugar (33.3 MMT raw equivalent) (Table 4). An expectation of an improved sugar recovery rate for the second consecutive year, increases in cane crushing volume as a result of larger cane production, and assumed benefits from higher cane by-product production (for integrated mills) should encourage higher sugar production.

However, declining sugar prices in conjunction with a rising Fair and Remunerative Price (FRP)/State Advised Price (SAP) for MY 2017/18 (Table 7) has increased the backlog of the sugar companies' dues payable to the farmers in the ongoing season, particularly in states where cane costs are not directly linked to Revenue Sharing Formula (RSF). In latter case, farmers are paid the FRP as a first installment; if dues to farmers under the RSF are more than the FRP, then they will be entitled to a second payment.

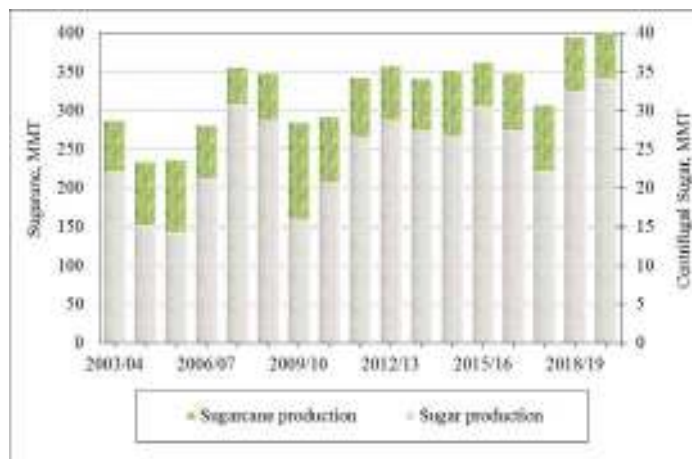

### Consumption

Out-year sugar consumption is forecast at 27.5 MMT, four percent above the current year estimate of 26.5 MMT. A strong demand from bulk buyers, food processors’, quick service restaurants, sweet meat shops, households, a growing population, rising income and changing food consumption patterns should support higher consumption in the out-year. Bulk users account for two-third of total sugar consumption in India. In addition to the above, most khandasari sugar is consumed by local sweet shops and gur is mostly consumed in rural households for food, and feed use as well.

(Source: USDA Foreign Agricultural Services – Global Agricultural Information Network – India Sugar Annual 2018; [https://gain.fas.usda.gov/Recent%20GAIN%20Publications/Sugar%20Annual\\_New%20Delhi\\_India\\_4-10-2017.pdf](https://gain.fas.usda.gov/Recent%20GAIN%20Publications/Sugar%20Annual_New%20Delhi_India_4-10-2017.pdf) )

Most khandasari sugar is consumed by local sweet shops and gur is mostly consumed in rural households and for feed use. India’s stable economy, rising incomes, growing young population, and changing consumption patterns are key drivers for food consumption.

### Market Prices

Sugar prices dropped more than 21 percent in the last 6 months due to more than sugar production in MY 2017/18. Compared to the corresponding period last year, sugar prices are down 7 percent despite firm Indian demand during the festival season (September – February). In fact, before falling, sugar prices (wholesale) rallied 62 percent in the last 27 months to peak at INR 40,300 per MT in October 2017.

Generally, gur prices move in tandem with sugar prices, either at a premium or at a discount. At current price levels it is selling at a discount to \$60 per MT to sugar (quoted at \$486 per MT). In fact, gur prices fell 26 percent in the last seven months in response to surplus cane production (Figure 2). Gur prices will follow domestic and international price movement for its future direction.

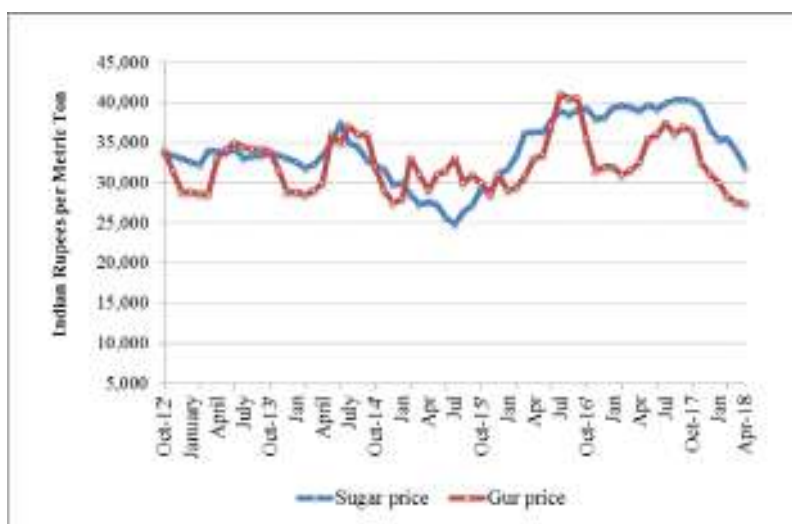

## POWER SECTOR IN INDIA

Power is one of the most critical components of infrastructure crucial for the economic growth and welfare of nations. The existence and development of adequate infrastructure is essential for sustained growth of the Indian economy.

India's power sector is one of the most diversified in the world. Sources of power generation range from conventional sources such as coal, lignite, natural gas, oil, hydro and nuclear power to viable non-conventional sources such as wind, solar, and agricultural and domestic waste. Electricity demand in the country has increased rapidly and is expected to rise further in the years to come. In order to meet the increasing demand for electricity in the country, massive addition to the installed generating capacity is required.

In May 2018, India ranked 4th in the Asia Pacific region out of 25 nations on an index that measures their overall power.

India ranks third among 40 countries in EY's Renewable Energy Country Attractiveness Index, on back of strong focus by the government on promoting renewable energy and implementation of projects in a time bound manner.

India has moved up 73 spots to rank 26th in the World Bank's list of electricity accessibility in 2017, according to Mr Piyush Goyal, Minister of State (Independent Charge) for Power, Coal, Renewable Energy and Mines, Government of India.

In September 2017, the Government of India launched the Saubhagya scheme to provide electricity connections to over 40 million families in rural and urban areas by December 2018 at a cost of US\$ 2.5 billion.  
(Source: <https://www.ibef.org/industry/power-sector-india.aspx>)

### Bagasse Co-generation Industry In India

When sugarcane is squeezed for its juice, a fibrous pulp material is left over. This material is processed into a usable form called 'bagasse'. For each 10 tonnes of sugarcane crushed, nearly 3 tonnes of wet bagasse is produced. Bagasse is typically used to produce heat and electricity in sugar mills (this is known as cogeneration), but can also be used for a variety of other purposes such as to make paper, cattle feed and even disposable food containers. It helps sugar mills to meet 100% of their energy needs. This is important, as sugar milling is highly energy intensive. Furthermore, sugar milling seasons often coincide with peak demand loads, so sugar mills can benefit immensely from the opportunity to sell surplus electricity to the grid at peak power rates. The facilities needed to generate heat and electricity from bagasse are often located at or near the sugar mill. Generating heat and electricity at the point of energy demand removes the need for costly transportation of the bagasse; involves minimal transmission and distribution costs; and reduces network losses and augmentation. Energy from bagasse generates less greenhouse gas emissions than conventional fossil-fuel generation.

Sugar industry has been traditionally practicing cogeneration by using bagasse as a fuel. With the advancement in the technology for generation and utilization of steam at high temperature and pressure, sugar industry can produce electricity and steam for their own requirements. It can also produce significant surplus electricity for sale to the grid using same quantity of bagasse. For example, if steam generation temperature/pressure is raised from 400°C to 485°C, more than 80 KWh of additional electricity can be produced for each ton of cane crushed. The sale of surplus power generated through optimum cogeneration would help a sugar mill to improve its viability, apart from adding to the power generation capacity of the country.

The Ministry has been implementing biomass power / co-generation programme since mid nineties. A total of approximately 500 biomass power and cogeneration projects aggregating to 4760 MW capacity have been installed in the country for feeding power to the grid. In addition, around 30 biomass power projects aggregating to about 350 MW are under various stages of implementation. Around 70 Cogeneration projects are under implementation with surplus capacity aggregating to 800 MW. States which have taken leadership position in implementation of bagasse cogeneration projects are Andhra Pradesh, Tamil Nadu, Karnataka, Maharashtra and Uttar Pradesh.  
(Source: <http://mnre.gov.in/schemes/grid-connected/biomass-powercogen/>)

### Thermal Power Industry In India

As on April 01, 2014, the total coal reserves in India stood at 301.564 billion tonnes, out of which 125.909 billion tonnes were proven reserves. The Government of India has set a generation capacity addition target of 88.5 GW during the period 2012-2017. Against this, generation capacity addition of 101.64 GW is likely to be achieved during said



period of 2012-2017. The generation capacity addition during 2017-2022 is being worked out considering the likely generation capacity addition of 101.64 GW during 2012-2017.

The revised tariff policy 2016 ensures adequate return on investment to companies engaged in power generation, transmission and distribution and ensures financial viability of the sector in order to attract investments by companies. Government of India through Ministry of Power launched the initiative of Ultra Mega Power Projects (UMPPs) i.e. 4,000 MW super thermal power projects (both pit head and imported coal based) in November 2005 with the objective to develop large capacity power projects in India. Power Finance Corporation Ltd (PFC) has been appointed as the Nodal Agency to facilitate the development of these projects. Various inputs for the UMPPs are tied up by the Special Purpose Vehicle (SPV) with assistance of Ministry of Power & Central Electricity Authority (CEA). CEA is involved in selection of sites for these UMPPs.

(Source: <http://www.makeinindia.com/sector/thermal-power>)

## **SUGARCANE BASED DISTILLERY / ETHANOL INDUSTRY**

In India, alcohol is currently produced from molasses. Alcohol is used as a raw material for industrial uses, for production of potable alcohol and as fuel ethanol. Fuel ethanol can be used as a substitute for gasoline. The realization from fuel ethanol is dependent on the government mandated price, which is paid by the oil marketing companies. In addition to this, fuel ethanol has the potential to generate revenues through carbon credits, as is the case with bio-diesel.

## **INDIAN MADE FOREIGN LIQUOR (IMFL)**

India is the third largest global spirits market by volume in the world, just behind China and Russia. In some states, certain alcoholic beverages like wine and beer can be sold in supermarkets that further increase the availability. The Indian alcohol industry is a high-risk industry, on account of the high taxes and innumerable regulations governing it. The Indian liquor industry comprises the Indian Made Foreign Liquor (IMFL), country liquor, foreign Liquor Bottled in Origin (BIO), illicit alcohol, beer and wine segments. The overall IML market is increasing at the rate of 9 to 10 per cent annually. Country liquor produced in local licensed distilleries and is made of cheap raw material, primarily rectified spirits of grains or molasses.

An Alcoholic beverage is a drink containing ethyl alcohol of agricultural origin in any percentage, derived either through natural fermentation, or addition during process. Ethanol or ethyl alcohol is produced through a natural process when the yeast converts the sugar contained in fruit, cereals and sugarcane, into alcohol. Pure alcohol is a colourless, pure liquid. The process used for its preparation is called fermentation. The Indian liquor market is concentrated in the southern part of the country, with the region accounting for about 60% of total IML sales and 45% of total beer sales. Andhra Pradesh is the largest consumer of both while Karnataka and Maharashtra are the second-largest consumers of IML and beer respectively.

(Source: <http://epaper.livemint.com/epaper/viewer.aspx> dated 25th November 2017)

## **VINEGAR INDUSTRY IN INDIA**

Vinegar has been used across the world for over thousands of years. Driven by its multifunctional properties, vinegar is increasingly popular with consumers as new blends, applications, and specialty products continue to enter the market. Being a source of vitamin B-1, riboflavin as well as mineral salts, it is gaining popularity among the consumers for its numerous applications. Emerging as a functional food, it is primarily used as flavouring and preserving agent. Although, vinegar is majorly consumed in the food and beverage industry, it also finds applications in the healthcare industry, cleaning industry and agriculture industry. According to IMARC group, the global vinegar market has reached values worth around US\$ 1.26 billion in 2017 growing at a CAGR of 2.1% during 2010-2017.

(Source: <https://www.reportbuyer.com/product/4715194/vinegar-market-global-industry-trends-share-size-growth-opportunity-and-forecast-2017-2022.html>)

## SUMMARY OF OUR BUSINESS

We are an integrated sugar and other allied products manufacturing company operating from Belgaum District in the State of Karnataka which is designated as one of the “High Recovery zones” for sugar production by Government of India. We operate a single location sugar unit having licensed crushing capacity of 11,000 TCD. In addition to sugar we also manufacture other allied products like Rectified Spirits, Extra-Neutral Spirits, Indian Made Liquor, Vinegar, Compost, Carbon dioxide (CO<sub>2</sub>), etc. and are further engaged in the generation of Power for captive consumption as well as external sale. Our business can hence be broken up into five main segments namely Sugar, Co-Generation, Distillery, Indian Made Liquor (IML) and Vinegar.

In the year 2001, we commenced operations of manufacture of Distillery products such as Ethanol, Rectified Spirit and Extra Neutral Spirit. In the year 2006, our Company implemented backward integration and began commercial operations for Sugar manufacture from sugarcane, along with Co-Generation capabilities. During the year 2008, we began bottling of Indian Made Liquor. Currently our integrated unit processes sugarcane to produce sugar and the by-products are used to generate electricity for captive use and commercial sale, manufacture rectified spirit, ENA, IML, Vinegar, Press-mud and Compost. Over the years, we have expanded the production / manufacturing capacities of all our products. Our present licensed manufacturing capacity for our various products is given below:

Sr. No.	Product	Current Approved Capacity
1.	Sugar	2,42,000 Tons / Year <sup>(1)</sup>
2.	Bagasse	6,60,000 Tons / Year <sup>(1)</sup>
3.	Molasses	88,000 Tons / Year <sup>(1)</sup>
4.	Rectified Spirit	30,000 KL / Year
5.	Extra Neutral Alcohol (ENA)	21,000 KL / Year
6.	Industrial Ethanol	90,000 KL / Year
7.	Electricity / Power	4,96,800 MW / Hr
8.	Brewed Vinegar	34,500 Ltrs. / Day (10,350 KL / Year)

<sup>(1)</sup> The above licensed capacities are equivalent to a total Sugarcane crushing capacity of 11,000 TCD working for approximately 200 days per year (Crushing Season) at an average 11% recovery rate for sugar, 30% for Bagasse and 4% for Molasses.

Production of sugar, power and distillery products requires our Company to adopt stringent Quality Assurance and Quality Control standards (QA/QC). We have set-up indigenous laboratories for each department which ensures that quality of raw material used in the production process and also the finished goods delivered to our customers is subject to various tests. To access and facilitate compliance with applicable requirements, we regularly review our quality systems to determine their effectiveness and identify areas for improvement. This helps in improving our procurement process thus reducing wastages, returns and other related costs.

During the production of sugar; bagasse and molasses are produced which are the basic raw materials for power generation and Distillery (Spirit) manufacturing unit, respectively. The sugar unit of our integrated production facility first crushes sugarcane to extract juice and processes the juice to produce sugar. The sugar manufactured is then graded and packed based on the size of crystals and quality of the sugarcane. During the last fiscal year we produced 32,170 tonnes of sugar. After extracting the juice from sugarcane, the residual fibre leftover called Bagasse is used as a fuel for power generation. The molasses used in the process of sugar production is fermented and distilled to manufacture various spirits (Rectified Spirit and Extra Neutral Spirit) and IML in the distillery unit of our integrated production and manufacturing facility.

Bagasse is the fibrous residual matter used as a bio-fuel to generate steam in high pressure boilers for turning turbines to generate electricity. We obtain enough Bagasse during the crushing seasons, such that the electricity produced is used not just for captive consumption, but also for sale. For electricity generated over and above our captive consumption, we have entered into Power Purchase Agreements with 5 electricity distribution companies in Karnataka to supply a total of 22.4 MW. It is possible that during the year we may produce surplus energy and supply the surplus energy to other Companies / Industries based on demand.

Molasses is the viscous product resultant of refining sugarcane juice. Molasses, which forms the primary raw material for the distillery unit, is fermented, distilled and made to undergo various processes for making rectified spirit and extra neutral spirit. Rectified Spirit is processed to manufacture Industrial Vinegar. Extra- Neutral spirit is further processed for manufacture of IML products. The Extra-Neutral spirit is blended to manufacture Whiskey which is sold by us under our various brands like VSL Deluxe Whisky, District-1 and VSL Black. During the last financial year, we

manufactured approximately 1,23,060 boxes of IML, 1,07,79 KL of Industrial Vinegar, 3156.59 KL of Rectified Spirit and 969.47 KL of Extra-Neutral Spirit.

Further the waste water extracted from Distillery unit is called as spentwash which is further mixed with mud to form Compost / Organic Manure, which is supplied back to farmers for cultivation of their fields which ensures higher yields. Further the company has set up a CO<sub>2</sub> plant also. Thus, we believe that nothing is wasted, as every single output whether residue or by-product is utilised.

## **OUR COMPETITIVE STRENGTHS**

### **Experienced Promoters and strong Executive Team**

Our Promoters are engaged in the business of distillery and sugar production from sugarcane for more than a decade and have thus established a proven background and rich experience in the sugar and derived product industry. In the year 2001, our Promoters were part of the commencing business of a small distillery unit in Bellad, near Belgaum, Karnataka with a capacity of 35 KLPD. With their business acumen and foresight, our Promoters, in the year 2006, undertook backward integration and started the sugar production unit and also a co-generation unit with a capacity of 2500 TCD and 14 MW respectively. With the continued support of the farming community in the area we were able to expand our sugar unit capacity from 2500 TCD to 5500 TCD in the year 2009. This further led to the enhancement in our power generation capacity from 14 MW to 36.4 MW. Today our Company has an integrated manufacturing unit for products ranging from Sugar to electricity generation, rectified spirit, IML, vinegar to compost, thus utilising technically the entire waste from sugar production. For further details of our Promoter's experience and background, please refer the chapter titled "*Our Promoters and Promoter Group*" on page no. 188 of this Red Herring Prospectus.

Also, our Company and our Promoters are aided by a team of experienced personnel. The team comprises of personnel having technical, operational and business development experience. We believe that our management team's experience and their understanding of the sugar production & derived product manufacturing business will enable us to continue to take advantage of both current and future market opportunities. It is also expected that our management personnel's experience will to help us in addressing and mitigating various risks inherent in our business, including significant competition, reliance on independent agents, and fluctuations in sugar and sugarcane prices.

Our team includes senior executives and managers, many of whom are having over 15-20 years experience in the engineering and sugar industry. We believe our management and executive team has the long-term vision to provide stability and continuity to our businesses.

### **Wide range of products**

The process of production of sugar produces various residual materials and by-products like Bagasse and Molasses. These residual materials are used by us as raw materials for manufacturing further products. The Bagasse, which is a dry residue after the sugar production process is used to generate electricity by burning the same in the Boilers. Molasses is used in the distillery unit to make a range of products like rectified spirit, ENA and IML and the rectified spirit so produced is used in the production of Industrial Vinegar. Also surplus Molasses is sold directly to other distillery units. Further, the mud generated in the sugar process is used along with certain distillery unit wastes to produce CO<sub>2</sub>, press mud and compost.

The customers of different products cover a wide range of industrial sectors like FMCG, Government agencies, Food industry and Cold Storage industry to name a few. The above wide range of products gives us a large market for each product. We have made sugar sales to various wholesalers, FMCG companies and also to local and state government agencies. Our distillery products; rectified spirit and ENA are sold to various other standalone distillery units who process it for further industrial use or to make liquor. Though the IML manufactured by us is sold only through KSBCL, our products are supplied to various wholesalers and retailers in the state of Karnataka through KSBCL. The Industrial Vinegar manufactured by us is mainly sold as preservatives and also for certain industrial uses. We have entered into a PPA with electricity supply companies for sale of our surplus power so generated. Further, other by-product like CO<sub>2</sub> is sold as a gas and liquefied CO<sub>2</sub> which has different applications in several industries from medicine, food storage, electronics and agriculture. Once the sugar production is started, we are in a position to always provide raw materials to the other products in sufficient quantities for captive consumption and also for external sale. For further details, regarding our product portfolio, please refer "*Our Business – Our Products*" on page no. 136 of this Red Herring Prospectus.

## **Integrated operations and economies of scale**

We have integrated operations enabling us to meet the time, cost efficiency, quality and quantity requirements. The residual material and by-products generated from the production process of one product is used as a raw material for manufacturing another product. Thus our diversified but integrated business model provides most of the necessary raw materials in-house for the various business segment products leading to reduced costs and control over the input material. Our unit has been setup such that the residual materials from one production process are transported to their respective product units either via pipes or conveyor belts or other in-house transport mechanism. This provides us seamless flow of raw material for all our products and also enables us to transport the surplus materials, if, any, for direct sale. This integration allows us not only to save enormous costs and have less dependence on third party for input materials, but also helps us achieve economies of scale by controlling the inputs / production based on each previous process, improving our efficiency and margins.

The main raw material for production of our various segments is sugarcane and our integrated unit processes each component of the sugarcane to manufacture a variety of products relating to the food and beverage industry. Further, with approximately 49 villages from whom we procure our sugarcane produce uninterruptedly till date, we are also able to achieve economies of scale by bulk buying from the farmers.

## **Strong Technological Capabilities**

Our integrated manufacturing unit situated at Bellad-Bagewadi has been installed with various latest machinery and technology. We have installed The Distributed Control System (DCS) at our sugarcane milling and co-generation facilities for precision system management. The DCS is a type of automated control system that is distributed throughout a machine to provide instructions to different parts of the machine. Instead of having a centrally located device controlling all machines each section of a machine has its own computer that controls the operation. DCS is commonly used in manufacturing equipment and utilises input and output protocols to control the machine. The entire system of controllers is connected by networks for communication and monitoring. The successful installation of the DCS which enables us to achieve reduced cost, reduced environmental effect, higher efficiency and reduced response time, reliability of equipment, ease of maintenance and conservation of energy.

We have also installed the latest machineries for our Distillery and Vinegar units. In the financial year 2016-17, we installed a Tetra Packaging machine for our IML products which not only saves our considerable bottling cost but also helps us in our endeavour to protect the environment by reducing glass / plastic bottles being discarded after use. The machinery used for manufacture of Vinegar has been imported from China and we use the latest technology for processing the diluted ethanol into Vinegar.

## **Strategic location of our manufacturing unit**

Sugarcane is the principal raw material used for the production of sugar. Our business depends on the availability of sugarcane and any shortage of sugarcane may adversely affect our results of operations. After de-regulation of the sugar industry, there are no restrictions on the farmers to sell their produce to any particular sugar unit. However, due to our continued relations with the farmers, are regular and advance payments, assistance with high quality seeds and timely aid in harvesting and transportation of the cane, we have ensured continuous supply of sugarcane from a large number of farmers in the nearby villages in our vicinity and other areas. As per the earlier cane area allotted order to our Company by the Sugarcane Commissioner, Bangalore, there were 28 villages in Taluka Hukkeri, 12 villages in Taluka Chikkodi and 9 villages in Taluka Gokak in Belgaum District reserved for the supply of sugarcane to our factory.

Over the period of time, there has been a considerable increase in the acreage of sugarcane cultivation in the nearby villages thus increasing the sugarcane growing areas. To tap this increase, in the F. Y. 2015-16 increased our installed capacity from 5,500 TCD to 8,500 TCD. Though, due to poor rainfall the sugarcane production has been affected, in turn impacting our utilisation, we believe that the larger sugarcane area will provide us with ample supply in seasons of good rain. Also, having a large sugarcane supply base ensures that, in times of cane shortage, due to its long standing relationships with farmers, the factory gets a considerable share of the cane available in the vicinity of our factory. Also, a simultaneously large sugarcane crushing capacity also ensures a larger stock of Bagasse for the co-generation of power, as also a substantial increase in the Molasses available for our distillation business.

Besides, our factory unit is located approximately 70 kms from the main city of Belgaum, which has established road and rail connections to various major cities like Bangalore, Chennai, Mumbai, Pune and Goa. The air route from Belgaum is also constantly growing which enables certain urgent transportation possible.

### **Cordial and strong relationships with sugarcane farmers**

We had approximately 49 villages allotted to us under the cane area allotment order by the Sugarcane Commissioner of Bangalore, in the vicinity of our factory unit and have cordial relations with every farmer in the nearby areas. We have maintained good and cordial relations with large sugarcane growing farmer base so as to ensure un-interrupted supply of sugarcane and within the required time period. Besides making timely payments to sugarcane farmers, we provide them with high-quality sugarcane seeds at subsidised rates, thus being an integral part of the cane development process. This not only helps us in ensuring the supply of sugarcane to us but also ensures quality of the sugarcane so that the recovery from these sugarcanes is good. We have entered into agreements for harvesting and transporting of sugarcane produced by the farmers, for no cost to the farmers. The harvesting and transporting groups are paid by our Company and this cane procurement activity ensures the harvested produce is transported to our factory for crushing.

Besides, the raw material procurement, our Company has also established many shops, local hotels and eating places for the convenience of the farmers when they come to our factory unit to sell their produce. These amenities keep the farmers happy and help us build and maintain a good and cordial relationship. Despite the cyclical nature of the sugar industry, we keep strong ties with the desired sugarcane growing farmers. We believe that these relationships are a competitive advantage as farmers have no obligation to sell their produce to us and they are free to sell to any sugar factory. Also, assisting the farmers with seeds, irrigation etc, ensures that the farmers do not switch to other crops that may be more profitable.

### **Captive Power plant and exportable capacity**

Power is an important factor in every manufacturing facility. Considering the integrated nature of our manufacturing unit and its corresponding power requirements, we have installed a power plant with electricity generation capacity of 14 MW and 22.4 MW (from Bagasse / Coal). Our entire electricity requirement during the crushing season is met out of the electricity generated by us in-house. Also, the captive power generation gives us stable and uninterrupted power supply which is very crucial in manufacturing of our products. It further gives us steady and quality supply of steam for our various processes in the sugar, co-generation and distillery units. Uninterrupted power supply helps to avoid any delays in manufacturing process thereby ensuring optimum utilization of our capacities and reducing external electricity costs, especially during the crushing season.

With a total co-generation capacity of 36.4 MW, we ideally use approximately 14 MW for our captive consumption. The remaining electricity generated is sold to third parties through a PPA or an open sale. Currently, we have entered into a PPA for sale of balance MW electricity with 5 different electricity supply companies.

Further, we have installed various energy saving devices at our production facilities such as planetary gear boxes, variable frequency drives, swing type fibrizor, high efficiency pumps and energy efficient motors which help us reducing the consumption of energy in our crushing operations. We have also installed planetary gear boxes in our boiling house section and have further introduced energy efficient condensers and unforced cooling tower as power saving measures. Similarly, in the co-generation unit, our power consumption has been reduced due to installation of a spray pond instead of forced draught cooling tower. Due to the implementation of the above measures we have been able to reduce our captive consumption leading to higher availability of exportable power.

**For risks related to our business, our Company and our industry, see “Risk Factors” on page no. 17 of this Prospectus.**

## **OUR STRATEGIES**

Our strategic objective is to improve and consolidate our position as a sugar manufacturer with a continuous growth philosophy. The diagram below represents our continuous growth philosophy being implemented on a day-to-day basis.

Our continuous growth philosophy is being driven with the strategic levers of operational excellence, strengthening existing services, customer satisfaction, ecosystem development, innovation and marketing.

### ***Increasing operational efficiency***

Our product portfolio consists of sugar and various other products manufactured by processing its residual products. Hence operational efficiency for each product is related to its previous product's efficiency and quality. We continue to invest in increasing our operational efficiency throughout the organisation. We are addressing the increase in



operational output through continuous process improvement, increasing recovery rate through timely sugarcane crushing, technology development throughout the products, consistent quality and customer service. We also strive to achieve alignment of our people towards 'process improvement' through change management and upgrading of skills for latest technology and as required for customer satisfaction is a continuous activity. Awareness of this quality commitment is wide spread among all the employees.

### ***Explore possibilities of geographical expansion***

Our Company is currently situated in the area of Bellad Bagewadi and our Company intends to propose to explore other geographical locations within the Belgaum District. Our Company, with intent of exploring new location with significant sugarcane cultivation area and abundant sugarcane growth has acquired a land of approximately 9 acres and 12 Gunthas by way of 'Full Paid Power of Attorney'. For details of the land purchased, please see the section "*Properties – Our Business*" on page no. 151 of this Red Herring Prospectus. However, our Company is still at planning stage and has neither finalised any specific utilisation for the said land nor any plans have been put forth regarding the funding, capacity, products and other details.

### ***Addition of new IML products***

Our IML products currently consist of only whisky which is mainly sold under our brand "VSL Deluxe Whisky". Besides, we also have whisky brands like "District – 1" and "VSL Black". With the success of our whisky brands, our Company intends to launch other products like Rum, Gin and Vodka under the same brand. Our Company has already obtained the relevant approvals for these products and currently in the testing stage of these products.

Our IML products currently contribute approximately 8% of our total revenue from operations. We believe that the addition of these new products will enable us to cater to a bigger market and also enable us to cater to customers of larger demographic base. Further, different products with the existing brand name will allow us greater brand recognition and also enable us to enter different markets with a large product portfolio.

### ***Augment our fund based capacities in order to scale up business operations***

The sugar industry is characterised by high debtors and advance payments to farmers and harvesting & transportation agents. Our customers, mainly being entities in the food, petroleum, beverages, and also government agencies, we generally offer substantial credit period to them. Further, during the crushing season, we have to make advance payments for various minor raw materials, utilities and other services so as to carry out the un-interrupted crushing. Thus our operations are working capital intensive.

It is hence our strategy to raise funds from this issue and augment our fund based working capital capabilities. We believe that companies with high liquidity on their balance sheet would be able to better negotiate with sugarcane suppliers. With the de-regulation of the sugar industry, farmers are free to sell their produce where they like and are not obligated to sell any portion of the same to us. Better liquidity will also provide us with sufficient incentives to ensure the farmers prefer us for selling their sugarcane produce in each season. Also, we invest a portion of our working capital to provide some of our farmers with high quality seeds for better crop quality. Additional working capital will enable us to offer such high quality seeds on larger quantities and to a large farmer base. Funding this working capital requirement from the proceeds of the Fresh Issue will also enable us to save a considerable interest cost due to lower working capital borrowings. For further details regarding the working capital being raised through this Offer, please refer to section "*Objects of the Offer*" on page no. 102 of the Red Herring Prospectus.

**SUMMARY OF FINANCIAL INFORMATION**

**Annexure I**  
**STATEMENT OF ASSETS AND LIABILITIES, AS RESTATED**

*(₹ in lakhs)*

Particulars	As at March 31,				
	2019	2018	2017 (Proforma)	2016 (Proforma)	2015 (Proforma)
<b>ASSETS</b>					
<b>NON-CURRENT ASSETS</b>					
Property, Plant and Equipments	26,440.54	27,188.80	24,069.44	24,413.23	24,598.79
Capital Work-in-Progress	1,126.02	-	3,834.55	128.82	508.21
Intangible Assets	-	-	-	-	-
Financial Assets:					
i. Investments	108.24	53.24	37.98	37.65	37.65
ii. Other financial assets	214.60	213.45	262.89	263.18	265.18
Deferred Tax Assets (Net)	-	-	-	-	-
Other Non-Current Assets	-	-	-	-	-
<b>Total Non – Current Assets</b>	<b>27,889.40</b>	<b>27,455.49</b>	<b>28,204.86</b>	<b>24,842.88</b>	<b>25,409.83</b>
<b>CURRENT ASSETS</b>					
Inventories	32,434.62	26,157.20	18,199.84	24,446.57	26,953.98
Financial assets:					
i. Trade Receivables	3,835.87	3,388.06	4,435.39	1,857.18	1,249.79
ii. Cash & Cash Equivalents	169.35	671.02	1,242.07	5,135.81	1,977.55
iii. Bank Balances other than ii above.	15.00	74.70	31.58	29.13	14.88
iv. Others financial assets	4.47	4.61	15.52	44.64	0.22
Current Tax Assets (Net)	-	-	-	-	-
Other Current Assets	7,606.26	4,667.56	2,190.73	2,542.33	4,894.96
<b>Total Current Assets</b>	<b>44,053.93</b>	<b>34,963.14</b>	<b>26,115.13</b>	<b>34,055.65</b>	<b>35,091.37</b>
<b>TOTAL ASSETS</b>	<b>71,954.96</b>	<b>62,418.63</b>	<b>54,319.99</b>	<b>58,898.53</b>	<b>60,501.20</b>
<b>EQUITY AND LIABILITIES</b>					
<b>Shareholder's Funds</b>					
Equity Share Capital	3,455.60	3,455.60	3,455.60	3,455.60	3,455.60
Other Equity	17,694.09	19,432.35	19,793.19	19,153.66	19,533.82
<b>Total Equity</b>	<b>21,149.69</b>	<b>22,887.95</b>	<b>23,248.79</b>	<b>22,609.26</b>	<b>22,989.42</b>
<b>Non-Current Liabilities</b>					
Financial Liabilities:					
i. Borrowings	6,541.43	3,700.79	999.46	2,076.77	3,402.04
Provisions	182.65	167.96	209.72	211.65	116.58
Deferred Tax Liabilities(Net)	765.21	1,391.94	1,057.56	841.63	354.70
<b>Total Non-Current Liabilities</b>	<b>7,489.29</b>	<b>5,260.69</b>	<b>2,266.75</b>	<b>3,130.06</b>	<b>3,873.33</b>
<b>Current Liabilities</b>					
Financial Liabilities:					

i. Borrowings	25,385.68	26,467.77	21,666.16	22,647.16	19,433.79
ii. Trade Payables	11,271.89	2,686.39	1,434.36	2,694.25	5,561.88
iii. Other Financial Liabilities	3,716.34	2,417.46	2,046.84	4,353.25	3,914.01
Other Current Liabilities	2,931.57	2,664.44	3,412.73	3,309.29	4,717.90
Provisions	10.49	12.36	12.17	114.79	6.76
Current Tax Liabilities (Net)	-	21.58	232.18	143.00	4.13
<b>Total Current Liabilities</b>	<b>43,315.97</b>	<b>34,269.99</b>	<b>28,804.45</b>	<b>33,159.21</b>	<b>33,638.46</b>
<b>TOTAL LIABILITIES</b>	<b>71,954.96</b>	<b>62,418.63</b>	<b>54,319.99</b>	<b>58,898.53</b>	<b>60,501.20</b>

**Annexure II**  
**STATEMENT OF PROFIT AND LOSS ACCOUNT, AS RESTATED**

(₹ in lakhs)

Particulars	For the year ended March 31,				
	2019	2018	2017 (Proforma)	2016 (Proforma)	2015 (Proforma)
<b>INCOME</b>					
Revenue from Operations (inclusive of excise duty)	30,679.58	25,928.30	32,184.21	40,575.83	34,508.36
Other Income	107.97	964.80	103.91	288.73	428.02
<b>Total Income</b>	<b>30,787.55</b>	<b>26,893.11</b>	<b>32,289.84</b>	<b>40,864.55</b>	<b>34,936.75</b>
<b>EXPENDITURE</b>					
Cost of Materials Consumed	27,665.37	22,695.78	12,819.41	22,928.76	23,239.60
Change in Inventories of Finished goods, Work-in-progress	(6,280.27)	(7,894.47)	6,292.78	2,535.09	(2,323.23)
Other Manufacturing Expenses	2,058.96	2,425.34	2,375.51	2,455.17	2,298.66
Excise Duty	2,044.29	3,746.95	3,782.47	7,011.17	6,883.51
Employee Benefit Expenses	1,303.28	1,242.97	1,361.77	1,215.76	1,190.65
Finance Costs	3,635.69	2,085.05	2,491.41	1,787.34	1,608.98
Depreciation & Amortisation	1,334.28	1,319.96	1,153.47	1,133.96	1,011.33
Other Expenses	1,414.66	1,357.72	965.95	1,069.57	1,039.63
<b>Total Expenses :</b>	<b>33,176.27</b>	<b>26,979.30</b>	<b>31,242.78</b>	<b>40,136.83</b>	<b>34,949.14</b>
<b>Profit / (Loss) Before Tax</b>	<b>(2,388.72)</b>	<b>(86.20)</b>	<b>1,045.34</b>	<b>727.73</b>	<b>(12.77)</b>
Tax Expenses:					
- Current Tax	-	6.08	223.16	155.45	6.36
- Deferred Tax Charge/(Credit)	(626.72)	334.38	215.93	486.93	38.57
<b>Total Tax Expenses</b>	<b>(626.72)</b>	<b>340.47</b>	<b>439.09</b>	<b>642.38</b>	<b>44.92</b>
<b>Profit / (Loss) After Tax</b>	<b>(1,761.99)</b>	<b>(426.67)</b>	<b>606.25</b>	<b>85.35</b>	<b>(57.68)</b>
<b>Other Comprehensive Income</b>					
i. Items that will not be reclassified to Profit or loss	23.74	81.32	42.31	(61.10)	(11.72)
ii. Income tax relating to items that will not be reclassified to Profit or loss	-	(15.50)	(9.03)	12.46	2.23
<b>Total Comprehensive Income</b>	<b>(1,738.26)</b>	<b>(360.85)</b>	<b>639.53</b>	<b>36.71</b>	<b>(67.17)</b>
<b>Earnings Per Share (in ₹)</b>					
<b>Basic and Diluted</b>	(5.10)	(1.23)	1.75	0.25	(0.17)

**Annexure III**  
**CASH FLOW STATEMENT, AS RESTATED**

(₹ in lakhs)

Particulars	For the year ended March 31,				
	2019	2018	2017 (Proforma)	2016 (Proforma)	2015 (Proforma)
<b>Cash flow from operating activities:</b>					
Net Profit before tax	(2,388.72)	(86.20)	1,045.34	727.73	(12.77)
Adjusted for:					
Depreciation & Amortisation	1,334.28	1,319.96	1,153.47	1,133.96	1,011.33
Dividend	(3.41)	(3.40)	(4.30)	(0.02)	(0.03)
Profit/ (Loss) on sale of assets	83.72	5.03	4.79	8.33	5.16
Interest & Financial Charges	3,635.69	2,085.05	2,491.41	1,787.34	1,608.98
<b>Operating Profit Before Working Capital Changes</b>	<b>2,661.56</b>	<b>3,320.44</b>	<b>4,690.71</b>	<b>3,657.34</b>	<b>2,612.68</b>
Adjusted for (Increase)/ Decrease in:					
Trade Receivables	(447.81)	1,047.34	(2,578.21)	(607.39)	2,812.74
Inventories	(6,277.42)	(7,957.36)	6,246.73	2,507.41	(2,451.75)
Other Current Assets	(2,938.70)	(2,476.83)	351.59	2,352.63	(464.72)
Other Financial Assets	(1.01)	60.36	29.41	(42.43)	0.48
Trade Payables	8,585.51	1,252.03	(1,259.89)	(2,867.63)	(1,660.58)
Provisions	36.56	39.75	40.27	39.49	21.76
Other Financial Liabilities	642.04	235.08	(1,311.09)	(626.04)	575.23
Other Current Liabilities	267.13	(748.30)	103.45	(1,408.61)	1,570.34
<b>Cash Generated From Operations Before Extra-Ordinary Items</b>	<b>2,527.85</b>	<b>(5,227.49)</b>	<b>6,312.96</b>	<b>3,004.77</b>	<b>3,016.18</b>
<b>Cash Generated From Operations</b>	<b>2,527.85</b>	<b>(5,227.49)</b>	<b>6,312.96</b>	<b>3,004.77</b>	<b>3,016.18</b>
Direct Tax Paid	21.58	232.18	143.00	4.13	462.67
<b>Net Cash Flow from/(used in) Operating Activities: (A)</b>	<b>2,506.27</b>	<b>(5,459.67)</b>	<b>6,169.97</b>	<b>3,000.65</b>	<b>2,553.52</b>
<b>Cash Flow From Investing Activities:</b>					
Purchase of Fixed Assets (Including CWIP)	(1,916.59)	(612.49)	(4,542.07)	(581.60)	(4,966.02)
Sale of Fixed Assets	120.83	2.68	21.88	4.26	1.83
Investment in Shares	(55.00)	(15.26)	(0.33)	-	(27.50)
Dividend Received	3.41	3.40	4.30	0.02	0.03
<b>Net Cash Flow from/(used in) Investing Activities: (B)</b>	<b>(1,847.34)</b>	<b>(621.67)</b>	<b>(4,516.22)</b>	<b>(577.33)</b>	<b>(4,991.65)</b>
<b>Cash Flow from Financing Activities:</b>					
Increase / (Decrease) in Long Term Borrowing	3,497.48	2,836.87	(1,970.11)	(362.50)	1,367.33
Increase / (Decrease) in Short Term Borrowing	(1,082.09)	4,801.61	(981.00)	3,213.37	3,989.56
Interest & Financial Charges	(3,635.69)	(2,085.05)	(2,491.41)	(1,787.34)	(1,608.98)
Dividend and Dividend Distribution Tax Paid	-	-	(102.52)	(314.35)	(401.62)
<b>Net Cash Flow from/(used in) Financing Activities (C)</b>	<b>(1,220.30)</b>	<b>5,553.43</b>	<b>(5,545.03)</b>	<b>749.19</b>	<b>3,346.29</b>
<b>Net Increase/(Decrease) in Cash &amp; Cash Equivalents (A+B+C)</b>	<b>(561.37)</b>	<b>(527.91)</b>	<b>(3,891.29)</b>	<b>3,172.50</b>	<b>908.16</b>
<b>Cash &amp; Cash Equivalents As At Beginning of the Year</b>	<b>745.72</b>	<b>1,273.65</b>	<b>5,164.93</b>	<b>1,992.43</b>	<b>1,084.27</b>
<b>Cash &amp; Cash Equivalents As At end of the Year</b>	<b>184.35</b>	<b>745.73</b>	<b>1,273.64</b>	<b>5,164.93</b>	<b>1,992.43</b>



## THE OFFER

The following table summarises the Offer details:

Equity Shares Issued	Particulars
Offer of Equity Shares <sup>(1)</sup>	Up to 1,00,00,000 Equity Shares, aggregating up to ₹ [●] Lakhs
<i>Of which:</i>	
Fresh Issue	Up to 30,00,000 Equity Shares, aggregating up to ₹ [●] Lakhs
Offer for Sale <sup>(2)</sup>	Up to 70,00,000 Equity Shares, aggregating up to ₹ [●] Lakhs
<i>The Offer consists of:</i>	
<b>A) QIB Portion<sup>(3)(4)</sup></b>	At least 10,00,000 Equity Shares
<i>of which:</i>	
Available for allocation to Mutual Funds only (5% of the QIB Portion)	Up to 50,000 Equity Shares
Balance for all QIBs including Mutual Funds	Up to 9,50,000 Equity Shares
<b>B) Non-Institutional Portion<sup>(4)</sup></b>	Not less than 40,00,000 Equity Shares
<b>C) Retail Portion<sup>(4)</sup></b>	Not less than 50,00,000 Equity Shares
<b>Pre and post Offer Equity Shares</b>	
Equity Shares outstanding prior to the Offer	3,45,56,000 Equity Shares
Equity Shares outstanding after the Offer <sup>(5)</sup>	Up to 3,75,56,000 Equity Shares
<b>Use of Net Proceeds</b>	See “ <i>Objects of the Offer</i> ” on page no. 102 of this Red Herring Prospectus for information about the use of the proceeds from the Fresh Issue. Our Company will not receive any proceeds from the Offer for Sale.

Allocation to all categories, except the Retail Portion, if any, shall be made on a proportionate basis, subject to valid Bids received at or above the Offer Price. The allocation to each Retail Individual Bidder shall not be less than the minimum Bid Lot, subject to availability of shares in Retail Portion, and the remaining available Equity Shares, if any, shall be Allocated on a proportionate basis. For further details, please refer the chapter “*Offer Procedure*” on page no. 330 of this Red Herring Prospectus.

<sup>(1)</sup> *The present Offer has been authorised by a resolution of the Board of Directors, dated November 20, 2017 and by a resolution of the shareholders of our Company in the Extra Ordinary General Meeting held on December 18, 2017.*

<sup>(2)</sup> *The Selling Shareholders severally and not jointly, specifically confirm that their portion of the Offered Shares, are held by them for a period of more than one year and that they are eligible in accordance with the SEBI ICDR Regulations. The Selling Shareholders have consented to the inclusion of their respective Offered Shares by way of their respective Selling Shareholder’s Consent Letters. For further details, please see “Annexure A - List of Selling Shareholders” on page no. 367 of this Red Herring Prospectus.*

<sup>(3)</sup> *5% of the QIB Portion shall be available for allocation on a proportionate basis to Mutual Funds only, and the remainder of the QIB Portion shall be available for allocation on a proportionate basis to all QIB Bidders, including Mutual Funds, subject to valid Bids being received at or above the Offer Price. Any unsubscribed portion in the Mutual Fund Portion will be added to the QIB Portion and allocated proportionately to the QIB Bidders in proportion to their Bids. For details, see “Offer Procedure” on page no. 330 of this DRHP. Allocation to all categories shall be made in accordance with SEBI ICDR Regulation.*

<sup>(4)</sup> *Subject to valid Bids being received at or above the Offer Price, under-subscription, if any, in any category except the QIB Portion, would be allowed to be met with spill over from any other category or combination of categories at the discretion of our Company and Selling Shareholders in consultation with the BRLM and the Designated Stock*

---

*Exchange. In the event of under-subscription in the Offer, Equity Shares shall be allocated in the manner specified in the section “Terms of the Offer” beginning on page no. 323 of this Red Herring Prospectus.*

*<sup>(5)</sup> Assuming full subscription of the Fresh Issue and transfer of all the Equity Shares offered for sale by the Selling Shareholders through the Offer for Sale.*

For further details, please see “Offer Related Information” and “Key Regulations and Policies” on page nos. 323 and 156, respectively, of this Red Herring Prospectus.

## GENERAL INFORMATION

Our Company was incorporated as a public limited company under the Companies Act, 1956 in the name and style Vishwanath Sugars Limited vide Certificate of Incorporation dated May 02, 1995 with the Registrar of Companies, Bangalore bearing Registration Number - 017730. Our Company was granted the Certificate of Commencement of Business by the Registrar of Companies, Bangalore on December 21, 1999. The name of our Company was subsequently changed to Vishwanath Sugar and Steel Limited and a Fresh Certificate of Incorporation consequent upon change of name was issued by the Registrar of Companies, Bangalore on December 28, 2010. The name of our Company was further changed to Vishwaraj Sugar Industries Limited and a Fresh Certificate of Incorporation Consequent upon change of name was issued by the Registrar of Companies, Bangalore on November 29, 2012.

For further details, please see chapter titled “*History and Certain Corporate Matters*” beginning on page no. 166 of this Red Herring Prospectus.

### Brief Company and Offer Information

Registered Office & Manufacturing Unit	
<b>Address:</b> Bellad Bagewadi, Taluka Hukkeri, District Belgaum – 591 305 <b>Tel No.:</b> +91 – 8333 – 251251 <b>Fax No.:</b> +91 – 8333 – 251322 <b>Email:</b> <a href="mailto:info@vsil.co.in">info@vsil.co.in</a> <b>Website:</b> <a href="http://www.vsil.co.in">www.vsil.co.in</a>	
<b>Date of Incorporation</b>	May 02, 1995
<b>Company Registration No.</b>	017730
<b>Company Identification No.</b>	U85110KA1995PLC017730
<b>Address of Registrar of Companies</b>	‘E’ Wing, 2 <sup>nd</sup> Floor, Kendriya Sadan, Bangalore – 560 034. <b>Tel No.:</b> +91 –080 – 2553 7449 / 2563 3104 <b>Fax No.:</b> +91 – 080 – 2553 8531
<b>Designated Stock Exchange</b>	BSE Limited
<b>Company Secretary &amp; Compliance Officer</b>	<b>Name:</b> Mrs. Sneha Patil <b>Address:</b> Bellad Bagewadi, Taluka Hukkeri, District Belgaum - 591305. <b>Tel. No.:</b> +91 – 8333 – 251251 <b>Fax No.:</b> +91 – 8333 – 251322 <b>Email:</b> <a href="mailto:cs@vsil.co.in">cs@vsil.co.in</a>
<b>Chief Financial Officer</b>	<b>Name:</b> Mr. Sheshagiri Kulkarni <b>Address:</b> Bellad Bagewadi, Taluka Hukkeri, District Belgaum - 591305. <b>Tel. No.:</b> +91 – 8333 – 251251 <b>Fax No.:</b> +91 – 8333 – 251322 <b>Email:</b> <a href="mailto:cfo@vsil.co.in">cfo@vsil.co.in</a>

### BOARD OF DIRECTORS OF OUR COMPANY

The following table set out the details of the Board of Directors of our Company:

Name	Designation	DIN	Address
Mr. Umesh Katti	Chairman and Non-Executive Director	01461050	No. 341, Bellad Bagewadi, Taluk : Hukkeri, Belgaum – 591 305
Mr. Nikhil Katti	Managing Director	02505734	No. 828, Vaccine Depot Road, Tilakwadi, Belgaum – 590 006
Mr. Lava Katti	Whole Time Director	02777164	H. No. 341, Katti Oni, Bellad Bagewadi, Belagavi – 591 309
Mr. Kush Katti	Whole Time Director	02777189	H. No. 341, Katti Oni, Bellad Bagewadi, Belagavi – 591 309
Mr. Mukesh Kumar	Whole Time Director	02827073	F-201, Mantri Paradise, Bannerghatta

	(Additional Director)		Road, Opp. Reliance Mart, Arekere Gate, Bilekahalli, Bangalore – 560 076
Mr. Surendra Khot	Non-Executive Independent Director	03504813	116, Ramtirth Nagar Belgaum (Kanbargi) Belgaum – 590 015
Mr. Shivanand Tubachi	Non-Executive Independent Director	07852525	Anugraha Plot No. 278, 2nd Sector, Shivabasav Nagar, Belgaum – 590 010
Mr. Basavaraj Hagaragi	Non-Executive Independent Director	07852512	House No. 1460/42, Pragati Housing Colony, Bellad Bagewadi, Hukkeri, Belgaum – 591 305
Mrs. Pratibha Munnolli	Non-Executive Independent Director	07852508	AT Post, Bellad Bagewadi, Taluka Hukkeri, Belgaum – 591 305
Mr. R. V. Radhakrishna	Non-Executive Independent Director	00763862	7-2-1760/A/104, Aakruti Avenue, St. No.4, Czech Colony, Sanathnagar, Hyderabad, Telangana – 500 018

For further details pertaining to the educational qualification and experience of our Directors, please see the chapter titled “*Our Management*” beginning on page no. 171 of this Red Herring Prospectus.

### Investor Grievances

**Investors can contact the Company Secretary and Compliance Officer, the BRLMs or the Registrar to the Offer in case of any pre-Offer or post-Offer related problems, such as non-receipt of letters of Allotment, non credit of Allotted Equity Shares in the respective beneficiary account, non receipt of refund orders and non-receipt of funds by electronic mode.**

All grievances relating to the ASBA process may be addressed to the Registrar to the Offer with a copy to the relevant Designated Intermediary to whom the ASBA Form was submitted. The Bidder should give full details such as name of the sole or First Bidder, ASBA Form number, Bidder DP ID, Client ID, PAN, date of the submission of ASBA Form, address of the Bidder, number of the Equity Shares applied for, ASBA Account number (for RIIs other than those bidding through the UPI Mechanism) or the UPI ID (for RIIs who make the payment of the Bid Amount through the UPI Mechanism) linked to the ASBA Account and the name and address of the Designated Intermediary where the ASBA Form was submitted by the ASBA Bidder.

Further, the investor shall also enclose a copy of the Acknowledgment Slip received from the Designated Intermediaries in addition to the information mentioned hereinabove.

### SELLING SHAREHOLDERS

Details of the Selling Shareholders in the Offer have been annexed as “*Annexure A*” on page no. 367 of this Red Herring Prospectus.

### Details of Key Intermediaries pertaining to this Offer and our Company

#### BOOK RUNNING LEAD MANAGER



#### ARYAMAN FINANCIAL SERVICES LIMITED

60, Khatau Building, Gr. Floor,  
Alkesh Dinesh Modi Marg, Opp. P.J. Tower (BSE Bldg.),  
Fort, Mumbai – 400 001  
Tel. No.: +91 – 22 – 6216 6999  
Fax No.: +91 – 22 – 2263 0434  
Website: [www.afsl.co.in](http://www.afsl.co.in)  
Email: [ipo@afsl.co.in](mailto:ipo@afsl.co.in)  
Investor Grievance Email: [feedback@afsl.co.in](mailto:feedback@afsl.co.in)  
Contact Person: Mr. Pranav Nagar  
SEBI Registration No.: INM000011344

## REGISTRAR TO THE OFFER



### **BIGSHARE SERVICES PRIVATE LIMITED**

1st Floor, Bharat Tin Works Building,  
Opp. Vasant Oasis, Makwana Road, Marol,  
Andheri East, Mumbai – 400 059  
Tel No.: +91 – 22 – 6263 8200  
Fax No.: +91 – 22 – 6263 8299  
Email: [ipo@bigshareonline.com](mailto:ipo@bigshareonline.com)  
Website: <http://www.bigshareonline.com>  
Contact Person: Mr. Ashish Bhope  
SEBI Registration No.: INR000001385

## LEGAL COUNSEL TO THE OFFER



### **M/S. KANGA & COMPANY (ADVOCATES & SOLICITORS)**

Readymoney Mansion,  
43, Veer Nariman Road,  
Mumbai- 400 001  
Tel No.: +91 – 22 – 66230000, +91 – 22 – 66332288  
Fax No.: +91 – 22 – 66339656 / 57  
Contact Person: Mr. Chetan Thakkar  
Email: [chetan.thakkar@kangacompany.com](mailto:chetan.thakkar@kangacompany.com)  
Website: [www.kangacompany.com](http://www.kangacompany.com)

## STATUTORY AUDITOR

### **M/S. GOJANUR & CO, Chartered Accountants**

No. 2 & 13, Basava Sadana Complex, Nehru Road,  
Shivamogga – 577 201, Karnataka.  
Tel No.: +91 – 08182 223443  
Email: [gojanur\\_cs@rediffmail.com](mailto:gojanur_cs@rediffmail.com)  
Firm Registration No.: 000941S  
Peer Review Registration No.: 011335  
Contact Person: Mr. G. M. Channappa Shetty

## BANKERS TO OUR COMPANY

### **THE BELAGAVI DISTRICT CENTRAL CO-OPERATIVE BANK LTD.**

Head Office, CTS No. 8692(A), Shivabasav Nagar,  
Near Shrinagar Garden Over Bridge,  
Belagavi – 590 016.  
Tel. No.: +91 – 94808 39502  
Fax No.: +91 – 831 – 242 5803  
Email: [bgmdccb@rediffmail.com](mailto:bgmdccb@rediffmail.com)  
Contact Person: Mr. Suresh K. Alagundi



### **BELLAD-BAGEWADI URBAN SOUHARDA SAHAKARI BANK**

Bellad Bagewadi, Taluka Hukkeri,  
District Belagavi – 591 305  
Tel No.: +91 – 833 – 326 7362 / +91 – 70266 26812  
Fax No.: +91 – 833 – 326 7362  
Email: [bbucbank@rediffmail.com](mailto:bbucbank@rediffmail.com) / [bbucbank16@gmail.com](mailto:bbucbank16@gmail.com)  
Website: [www.bagewadibank.com](http://www.bagewadibank.com)  
Contact Person: Mr. Sujeet M. Katti





**STATE BANK OF INDIA**

Ramesh Pride, 1<sup>st</sup> Floor, Congress Road,  
Tilakwadi, Belgaum – 590 006  
Tel No.: +91 – 831 – 240 0691  
Email: [sbi.04160@sbi.co.in](mailto:sbi.04160@sbi.co.in)  
Contact Person: RM – ME



**BANK OF INDIA**

SPM Road, Shahpur  
Belagavi – 590 003  
Tel No.: +91 – 831 – 240 7001  
Fax No.: +91 – 831 – 243 7195  
Email: shahapur. [hubbleidharwad@bankofindia.co.in](mailto:hubbleidharwad@bankofindia.co.in)  
Website: [www.bankofindia.co.in](http://www.bankofindia.co.in)  
Contact Person: Mr. Ajaya Bhanu

**BANKERS TO THE OFFER AND SPONSOR BANK**



**ICICI BANK LIMITED**

Capital Market Division, 1st Floor, 122, Mistry Bhavan  
Dinshaw Vachha Road, Backbay Reclamation  
Churchgate, Mumbai - 400 020  
**Tel No.:** +91 – 22 – 6681 8911 / 23 / 24  
**Fax No.:** +91 – 22 – 2261 1138  
**Email:** [kmr.saurabh@icicibank.com](mailto:kmr.saurabh@icicibank.com)  
**Website:** [www.icicibank.com](http://www.icicibank.com)  
**Contact Person:** Mr. Suarabh Kumar

**SYNDICATE MEMBERS**



**ARYAMAN FINANCIAL SERVICES LIMITED**

60, Khatau Building, Gr. Floor,  
Alkesh Dinesh Modi Marg, Opp. P.J. Tower (BSE Bldg.),  
Fort, Mumbai – 400 001  
**Tel. No.:** +91 – 22 – 6216 6999  
**Fax No.:** +91 – 22 – 2263 0434  
**Website:** [www.afsl.co.in](http://www.afsl.co.in); **Email:** [ipo@afsl.co.in](mailto:ipo@afsl.co.in)  
**Investor Grievance Email:** [feedback@afsl.co.in](mailto:feedback@afsl.co.in)  
**Contact Person:** Mr. Deepak Biyani  
**SEBI Registration No.:** INM000011344



**ARYAMAN CAPITAL MARKETS LIMITED**

60, Khatau Building, Gr. Floor,  
Alkesh Dinesh Modi Marg, Opp. P. J. Tower (BSE Bldg.),  
Fort, Mumbai – 400 001  
**Tel. No.:** +91 – 22 – 6216 6999  
**Fax No.:** +91 – 22 – 2263 0434  
**Email:** [aryacapm@gmail.com](mailto:aryacapm@gmail.com)  
**Contact Person:** Mr. Harshad Dhanawade  
**SEBI Registration No.:** INZ000004739

**SELF CERTIFIED SYNDICATE BANKS**

The banks registered with SEBI, which offer services, (i) in relation to ASBA, where the Bid Amount will be blocked by authorising an SCSB, a list of which is available on the website of SEBI at [www.sebi.gov.in/sebiweb/other/OtherAction.do?doRecognisedFpi=yes&intmId=34](http://www.sebi.gov.in/sebiweb/other/OtherAction.do?doRecognisedFpi=yes&intmId=34) and updated from time to time and

at such other websites as may be prescribed by SEBI from time to time, (ii) in relation to RIIs using the UPI Mechanism, a list of which is available on the website of SEBI at <https://sebi.gov.in/sebiweb/other/OtherAction.do?doRecognisedFpi=yes&intmId=40> or such other website as updated from time to time.

### **REGISTERED BROKERS**

The list of the Registered Brokers, including details such as postal address, telephone number and e-mail address, is provided on the website of the BSE and NSE, at [www.bseindia.com](http://www.bseindia.com) and [www.nseindia.com](http://www.nseindia.com), respectively, as updated from time to time.

### **REGISTRAR TO ISSUE AND SHARE TRANSFER AGENTS**

The list of the CRTAs eligible to accept Bid cum Applications forms at the Designated RTA Locations, including details such as address, telephone number and e-mail address, are provided on the website of Stock Exchange at <http://www.bseindia.com/static/markets/publicissues/rtadp.aspx?expandable=6> and [https://www.nseindia.com/products/content/equities/ipos/asba\\_procedures.htm](https://www.nseindia.com/products/content/equities/ipos/asba_procedures.htm), respectively, as updated from time to time.

### **COLLECTING DEPOSITORY PARTICIPANTS**

The list of the CDPs eligible to accept Bid cum Applications forms at the Designated CDP Locations, including details such as address, telephone number and e-mail address, are provided on the website of Stock Exchange at <http://www.bseindia.com/static/markets/publicissues/rtadp.aspx?expandable=6> and [https://www.nseindia.com/products/content/equities/ipos/asba\\_procedures.htm](https://www.nseindia.com/products/content/equities/ipos/asba_procedures.htm), respectively, as updated from time to time.

### **INTER-SE ALLOCATION OF RESPONSIBILITIES**

Aryaman Financial Services Limited is the Sole Book Running Lead Manager to this offer, and hence is responsible for all the offer management related activities.

### **MONITORING AGENCY**

As per Regulation 16(1) of the SEBI (ICDR) Regulations, 2009 the requirement of Monitoring Agency is not mandatory if the Fresh Issue size is below ₹ 10,000 lakhs and hence our Company has not appointed a monitoring agency for this offer.

Pursuant to Regulation 32(3) of the SEBI Listing Regulations, our Company shall on a quarterly yearly basis disclose to the Audit Committee the uses and application of the Net Proceeds. Until such time as any part of the Net Proceeds remains unutilized, our Company will disclose the utilization of the Net Proceeds under separate heads in our Company's balance sheet(s) clearly specifying the amount of and purpose for which Net Proceeds have been utilized so far, and details of amounts out of the Net Proceeds that have not been utilized so far, also indicating interim investments, if any, of such unutilized Net Proceeds. In the event that our Company is unable to utilize the entire amount that we have currently estimated for use out of the Net Proceeds in a fiscal, we will utilize such unutilized amount in the next fiscal.

Further, in accordance with Regulation 32(1)(a) of the SEBI Listing Regulations, our Company shall furnish to the Stock Exchanges on a quarterly yearly basis, a statement indicating material deviations, if any, in the utilisation of the Net Proceeds for the objects stated in this Prospectus.

### **IPO GRADING**

No credit agency registered with SEBI has been appointed in respect of obtaining grading for the Offer.

## TRUSTEES

This being an Offer of Equity Shares, the appointment of trustees is not required.

## DETAILS OF THE APPRAISING AUTHORITY

The objects of the Offer and deployment of funds are not appraised by any independent agency/ bank/ financial institution.

## CREDIT RATING

This being an Offer of Equity Shares, no credit rating is required.

## EXPERT OPINION

Except as stated below, our Company has not obtained any expert opinions:

Our Company has received written consent from the Statutory Auditors, namely, M/s. Gojanur & Co., Chartered Accountants, to include their names as required under section 26(1)(a)(v) of the Companies Act, 2013 in this Red Herring Prospectus / Prospectus and as an “Expert” as defined under section 2(38) of the Companies Act, 2013 in respect of the reports on the Restated Financial Statements dated July 08, 2019 and the Statement of Tax Benefits dated July 08, 2019, issued by them and included in this Red Herring Prospectus and such consents has not been withdrawn as on the date of this Red Herring Prospectus.

However, the term “expert” shall not be construed to mean an “expert” as defined under the U.S. Securities Act.

## BOOK BUILDING PROCESS

Book building, in the context of the Offer, refers to the process of collection of Bids from investors on the basis of the Red Herring Prospectus within the Price Band, which will be decided by our Company in consultation with the Selling Shareholders and BRLM, and advertised in all editions of Business Standard, all editions of Business Standard and Belgaum edition of the Kannada newspaper Kannada Prabha, which are widely circulated English, Hindi and Kannada newspapers respectively (Kannada being the regional language of Karnataka where our Registered Office is located) at least two Working Days prior to the Bid / Offer Opening Date and such advertisement shall be made available to Stock Exchanges for the purpose of uploading on their respective websites. The Offer Price shall be determined by our Company and the Selling Shareholders in consultation with the BRLM after the Bid/ Offer Closing Date.

**All potential investors are required to mandatorily use the Application Supported by Blocked Amount (“ASBA”) process including through UPI mode (as applicable) by providing details of the irrespective bank accounts which will be blocked by the Self Certified Syndicate Banks (“SCSBs”)**

The Offer Price shall be determined by our Company in consultation with Selling Shareholders and BRLMs after the Offer Closing Date. The principal parties involved in the Book Building Process are:

1. Our Company;
2. The Selling Shareholders;
3. Book Running Lead Manager;
4. The Syndicate Member(s) who are intermediaries registered with SEBI or registered as brokers with any of the Stock Exchanges and eligible to act as Underwriters;
5. The Registrar to the Offer;
6. The Escrow Collection Banks;
7. The SCSBs through whom ASBA Bidders would subscribe in this Offer;
8. The Registered Brokers, CDPs and CRTAs.

In accordance with the SEBI ICDR Regulations, QIBs and Non-Institutional Bidders are not permitted to withdraw their Bid(s) or lower the size of their Bid(s) (in terms of quantity of Equity Shares or the price) at any stage. Retail Individual Bidders can revise their Bid(s) during the Bid/Offer Period and withdraw their Bid(s) until the Bid/ Offer Closing Date. Except Allocation to RIIs, Allocation in the Offer will be on a proportionate basis.

The process of Book Building under the SEBI Regulations and the Bidding process are subject to change from time to time and the investors are advised to make their own judgment about investment through this process prior to submitting a Bid in the Offer.

For details on the method and procedure for bidding, see “Offer Procedure” on page no. 330 of this Red Herring Prospectus.

Investors should note the Offer is also subject to obtaining (i) the final listing and trading approvals of the Stock Exchanges, which our Company shall apply for after Allotment; and (ii) final approval of the RoC after the Prospectus is filed with the RoC.

#### Illustration of Book Building and Price Discovery Process

*(Investors should note that the following is solely for the purpose of illustrative and is not specific to this Offer, and does not illustrate bidding by Anchor Investors)*

For an illustration of the Book Building Process and the price discovery process, please refer the General Information Document for Investing in Public Issues.

#### OFFER PROGRAMME

An indicative timetable in respect of the Offer is set out below:

Event	Indicative Date
Bid/Offer Closing Date	October 04, 2019
Finalisation of Basis of Allotment with the Designated Stock Exchange	On or before October 11, 2019
Initiation of Refunds / unblocking of funds from ASBA Account	On or before October 14, 2019
Credit of Equity Shares to demat account of the Allottees	On or before October 15, 2019
Commencement of trading of the Equity Shares on the Stock Exchanges	On or before October 16, 2019

For further details on the Offer Programme, please see “Terms of the Offer” on page no. 323 of this Red Herring Prospectus.

#### UNDERWRITING AGREEMENT

After determination of the Offer Price and allocation of Equity Shares, but prior to the filing of the Prospectus with the RoC, our Company and the Selling Shareholders will enter into an Underwriting Agreement with the Underwriters for the Equity Shares proposed to be offered through the Offer. It is proposed that pursuant to the terms of the Underwriting Agreement, the BRLM will be responsible for bringing in the amount devolved in the event that the Syndicate Members do not fulfil their underwriting obligations. Pursuant to the terms of the Underwriting Agreement, the obligations of the Underwriters will be several and will be subject to certain conditions specified therein.

The Underwriting Agreement is dated [●]. The Underwriters have indicated their intention to underwrite the following number of Equity Shares:

*(This portion has been intentionally left blank and will be completed before filing the Prospectus with the RoC.)*

Name, address, telephone number, fax number and e-mail address of the Underwriters	Indicative number of Equity Shares to be underwritten	Amount underwritten (₹ in lakhs)
[●]	[●]	[●]
<b>TOTAL</b>	<b>[●]</b>	<b>[●]</b>



In the opinion of our Board of Directors (based on representations given by the Underwriters), resources of the Underwriters are sufficient to enable them to discharge their respective underwriting obligations in full. The above mentioned Underwriters are registered with SEBI under Section 12(1) of the SEBI Act or registered as brokers with the Stock Exchange(s).

Allocation among the Underwriters may not necessarily be in proportion to their underwriting commitment set forth in the table above. Notwithstanding the above table, the Underwriters shall be severally responsible for ensuring payment with respect to the Equity Shares allocated to investors procured by them in accordance with the Underwriting Agreement.

In the event of any default in payment, the respective Underwriter, in addition to other obligations defined in the Underwriting Agreement, will also be required to procure subscribers for or subscribe to the Equity Shares to the extent of the defaulted amount in accordance with the Underwriting Agreement.



## CAPITAL STRUCTURE

The Equity Share Capital of the Company as on the date of this Red Herring Prospectus and after giving effect to the Offer is set forth below:

(₹ in lakhs, except share data)

Sr. No.	Particulars	Aggregate Value at Nominal Value	Aggregate Value at Offer Price
<b>A</b>	<b>Authorised Share Capital</b>		
	6,00,00,000 Equity Shares of face value of ₹ 10 each	6,000.00	-
<b>B</b>	<b>Issued, Subscribed and Paid-up Share Capital before the Offer</b>		
	3,45,56,000 Equity Shares of face value of ₹ 10 each	3,455.60	-
<b>C</b>	<b>Present Offer in terms of this Red Herring Prospectus</b>		
	Public Offer of upto 1,00,00,000 Equity Shares of face value of ₹ 10 each	1,000.00	[●]
	<b>Which comprises:</b>		
	Fresh Offer of upto 30,00,000 Equity Shares of face value of ₹ 10 each <sup>(1)</sup>	300.00	[●]
	Offer for Sale of upto 70,00,000 Equity Shares of face value of ₹ 10 each <sup>(2)</sup>	700.00	[●]
<b>D</b>	<b>Issued, Subscribed and Paid-up Share Capital after the Offer</b>		
	3,75,56,000 Equity Shares of face value of ₹ 10 each	3,755.60	
<b>E</b>	<b>Securities Premium Account</b>		
	Before the Offer	1,466.39	
	After the Offer <sup>(3)</sup>		[●]

<sup>(1)</sup>The Offer has been authorised by the Board of Directors vide a resolution passed at its meeting held on November 20, 2017, and by the shareholders of our Company vide a special resolution passed pursuant to section 62 of the Companies Act, 2013 at the EGM held on December 18, 2017.

<sup>(2)</sup>The Selling Shareholders authorized offer of 70,00,000 Equity Shares in the Offer for Sale by way of letter dated November 16, 2017 and March 15, 2019. They have confirmed that the Equity Shares proposed to be offered and sold in the Offer are eligible to be offered for sale in accordance with the SEBI ICDR Regulations and has been held for a period of at least one year prior to the date of filing of the Draft Red Herring Prospectus with SEBI calculated in the manner as set out under Regulation 26(6) of SEBI ICDR Regulations. For further details, please see "Annexure A - List of Selling Shareholders" on page no. 367 of this Red Herring Prospectus.

<sup>(3)</sup>To be finalized upon determination of the Offer Price.

### Changes in our Authorised Share Capital

Since incorporation, the capital structure of our Company has been altered in the following manner:

- The initial authorised share capital of ₹ 50,00,000 divided into 5,000 Equity Shares of ₹ 1,000 each was increased to ₹ 10,00,00,000 divided into 1,00,000 Equity Shares of ₹ 1,000 each, pursuant to resolution of shareholders passed at the EGM held on December 11, 2000.
- The authorised share capital of ₹ 10,00,00,000 divided into 1,00,000 equity shares of ₹ 1,000 each was increased to ₹ 20,00,00,000 divided into 2,00,000 equity shares of ₹ 1,000 each, pursuant to resolution of shareholders passed at the EGM held on February 15, 2002.
- The authorised share capital of ₹ 20,00,00,000 divided into 2,00,000 equity shares of ₹ 1,000 each was increased to ₹ 30,00,00,000 divided into 3,00,000 equity shares of ₹ 1,000 each, pursuant to resolution of shareholders passed at the EGM held on January 18, 2003.

4. The authorised share capital of ₹ 30,00,00,000 divided into 3,00,000 equity shares of ₹ 1,000 each was increased to ₹ 35,00,00,000 divided into 3,50,000 equity shares of ₹ 1,000 each, pursuant to resolution of shareholders passed at the EGM held on July 05, 2005.
5. Split in authorised share capital ₹ 35,00,00,000 divided into 3,50,000 equity shares of ₹ 1,000/- each into 3,50,00,000 equity shares of ₹ 10/- each, pursuant to resolution of shareholders passed at the EGM held on May 13, 2010.
6. The authorised share capital of ₹ 35,00,00,000 divided into 3,50,00,000 equity shares of ₹ 10 each was increased to ₹ 50,00,00,000 divided into 5,00,00,000 equity shares of ₹ 10 each, pursuant to resolution of shareholders passed at the EGM held on May 13, 2010.
7. The authorised share capital of ₹ 50,00,00,000 divided into 5,00,00,000 equity shares of ₹ 10 each was increased to ₹ 60,00,00,000 divided into 6,00,00,000 equity shares of ₹ 10 each, pursuant to resolution of shareholders passed at the EGM held on February 15, 2011.

## NOTES TO CAPITAL STRUCTURE

### 1. Share Capital History of our Company

The following table sets forth the history of the equity share capital of our Company:

Date of Allotment of Equity Shares	No. of Equity Shares	Face Value (₹)	Issue Price (₹)	Nature / Reason of Allotment	Nature of Consideration	Cumulative No. of Equity Shares	Cumulative Paid Up Share Capital (₹)	Cumulative Share Premium (₹)
On Incorporation	35	1000	1000	Subscription to MoA <sup>(1)</sup>	Cash	35	35,000	Nil
December 11, 2000	60,007	1000	1000	Preferential Allotment <sup>(2)</sup>	Cash	60,042	6,00,42,000	Nil
February 23, 2002	40,195	1000	1000	Allotment of shares towards full satisfaction of compensation amount claimed by the owner of the land acquired for the purpose of the setting up project of the Company. <sup>(3)</sup>	Other than Cash	1,00,237	10,02,37,000	Nil
March 31, 2002	46,467	1000	1000	Preferential Allotment <sup>(4)</sup>	Cash	1,46,704	14,67,04,000	Nil
March 28, 2003	53,296	1000	1000	Preferential Allotment <sup>(5)</sup>	Cash	2,00,000	20,00,00,000	Nil

Date of Allotment of Equity Shares	No. of Equity Shares	Face Value (₹)	Issue Price (₹)	Nature / Reason of Allotment	Nature of Consideration	Cumulative No. of Equity Shares	Cumulative Paid Up Share Capital (₹)	Cumulative Share Premium (₹)
September 02, 2003	41,570	1000	1000	Preferential Allotment <sup>(6)</sup>	Cash	2,41,570	24,15,70,000	Nil
October 28, 2004	32,040	1000	1000	Preferential Allotment <sup>(7)</sup>	Cash	2,73,610	27,36,10,000	Nil
December 27, 2004	23,615	1000	1000	Preferential Allotment <sup>(8)</sup>	Cash	2,97,225	29,72,25,000	Nil
August 08, 2005	33,570	1000	1000	Preferential Allotment <sup>(9)</sup>	Cash	3,30,795	33,07,95,000	Nil
October 01, 2007 <sup>#1</sup>	174	1000	6000	Preferential Allotment <sup>(10)</sup>	Cash	3,30,969	33,09,69,000	8,70,000
October 06, 2007 <sup>#1</sup>	184	1000	6000	Preferential Allotment <sup>(11)</sup>	Cash	3,31,153	33,11,53,000	17,90,000
October 11, 2007 <sup>#1</sup>	179	1000	6000	Preferential Allotment <sup>(12)</sup>	Cash	3,31,332	33,13,32,000	26,85,000
October 16, 2007 <sup>#1</sup>	192	1000	6000	Preferential Allotment <sup>(13)</sup>	Cash	3,31,524	33,15,24,000	36,45,000
October 21, 2007 <sup>#1</sup>	196	1000	6000	Preferential Allotment <sup>(14)</sup>	Cash	3,31,720	33,17,20,000	46,25,000
October 26, 2007 <sup>#1</sup>	192	1000	6000	Preferential Allotment <sup>(15)</sup>	Cash	3,31,912	33,19,12,000	55,85,000
October 31, 2007 <sup>#1</sup>	195	1000	6000	Preferential Allotment <sup>(16)</sup>	Cash	3,32,107	33,21,07,000	65,60,000
November 05, 2007 <sup>#1</sup>	240	1000	6000	Preferential Allotment <sup>(17)</sup>	Cash	3,32,347	33,23,47,000	77,60,000
November 10, 2007 <sup>#1</sup>	240	1000	6000	Preferential Allotment <sup>(18)</sup>	Cash	3,32,587	33,25,87,000	89,60,000
November 15, 2007 <sup>#1</sup>	220	1000	6000	Preferential Allotment <sup>(19)</sup>	Cash	3,32,807	33,28,07,000	1,00,60,000
November 20, 2007 <sup>#1</sup>	177	1000	6000	Preferential Allotment <sup>(20)</sup>	Cash	3,32,984	33,29,84,000	1,09,45,000
November 25, 2007 <sup>#1</sup>	210	1000	6000	Preferential Allotment <sup>(21)</sup>	Cash	3,33,194	33,31,94,000	1,19,95,000

Date of Allotment of Equity Shares	No. of Equity Shares	Face Value (₹)	Issue Price (₹)	Nature / Reason of Allotment	Nature of Consideration	Cumulative No. of Equity Shares	Cumulative Paid Up Share Capital (₹)	Cumulative Share Premium (₹)
November 30, 2007 <sup>#1</sup>	1,105	1000	6000	Preferential Allotment <sup>(22)</sup>	Cash	3,34,299	33,42,99,000	1,75,20,000
December 05, 2007 <sup>#1</sup>	1,225	1000	6000	Preferential Allotment <sup>(23)</sup>	Cash	3,35,524	33,55,24,000	2,36,45,000
December 10, 2007 <sup>#1</sup>	842	1000	6000	Preferential Allotment <sup>(24)</sup>	Cash	3,36,366	33,63,66,000	2,78,55,000
December 15, 2007 <sup>#1</sup>	169	1000	6000	Preferential Allotment <sup>(25)</sup>	Cash	3,36,535	33,65,35,000	2,87,00,000
December 20, 2007 <sup>#1</sup>	162	1000	6000	Preferential Allotment <sup>(26)</sup>	Cash	3,36,697	33,66,97,000	2,95,10,000
December 25, 2007 <sup>#1</sup>	157	1000	6000	Preferential Allotment <sup>(27)</sup>	Cash	3,36,854	33,68,54,000	3,02,95,000
December 30, 2007 <sup>#1</sup>	158	1000	6000	Preferential Allotment <sup>(28)</sup>	Cash	3,37,012	33,70,12,000	3,10,85,000
January 04, 2008 <sup>#1</sup>	166	1000	6000	Preferential Allotment <sup>(29)</sup>	Cash	3,37,178	33,71,78,000	3,19,15,000
January 09, 2008 <sup>#1</sup>	171	1000	6000	Preferential Allotment <sup>(30)</sup>	Cash	3,37,349	33,73,49,000	3,27,70,000
January 14, 2008 <sup>#1</sup>	167	1000	6000	Preferential Allotment <sup>(31)</sup>	Cash	3,37,516	33,75,16,000	3,36,05,000
January 19, 2008 <sup>#1</sup>	274	1000	6000	Preferential Allotment <sup>(32)</sup>	Cash	3,37,790	33,77,90,000	3,49,75,000
January 24, 2008 <sup>#1</sup>	55	1000	6000	Preferential Allotment <sup>(33)</sup>	Cash	3,37,845	33,78,45,000	3,52,50,000
February 11, 2008 <sup>#1</sup>	157	1000	6000	Preferential Allotment <sup>(34)</sup>	Cash	3,38,002	33,80,02,000	3,60,35,000
February 13, 2008 <sup>#1</sup>	132	1000	6000	Preferential Allotment <sup>(35)</sup>	Cash	3,38,134	33,81,34,000	3,66,95,000
February 15, 2008 <sup>#1</sup>	115	1000	6000	Preferential Allotment <sup>(36)</sup>	Cash	3,38,249	33,82,49,000	3,72,70,000
February 18, 2008 <sup>#1</sup>	142	1000	6000	Preferential Allotment <sup>(37)</sup>	Cash	3,38,391	33,83,91,000	3,79,80,000

Date of Allotment of Equity Shares	No. of Equity Shares	Face Value (₹)	Issue Price (₹)	Nature / Reason of Allotment	Nature of Consideration	Cumulative No. of Equity Shares	Cumulative Paid Up Share Capital (₹)	Cumulative Share Premium (₹)	
February 20, 2008 <sup>#1</sup>	132	1000	6000	Preferential Allotment <sup>(38)</sup>	Cash	3,38,523	33,85,23,000	3,86,40,000	
February 22, 2008 <sup>#1</sup>	134	1000	6000	Preferential Allotment <sup>(39)</sup>	Cash	3,38,657	33,86,57,000	3,93,10,000	
February 23, 2008 <sup>#1</sup>	136	1000	6000	Preferential Allotment <sup>(40)</sup>	Cash	3,38,793	33,87,93,000	3,99,90,000	
February 25, 2008 <sup>#1</sup>	121	1000	6000	Preferential Allotment <sup>(41)</sup>	Cash	3,38,914	33,89,14,000	4,05,95,000	
February 27, 2008 <sup>#1</sup>	115	1000	6000	Preferential Allotment <sup>(42)</sup>	Cash	3,39,029	33,90,29,000	4,11,70,000	
February 28, 2008 <sup>#1</sup>	94	1000	6000	Preferential Allotment <sup>(43)</sup>	Cash	3,39,123	33,91,23,000	4,16,40,000	
February 29, 2008 <sup>#1</sup>	75	1000	6000	Preferential Allotment <sup>(44)</sup>	Cash	3,39,198	33,91,98,000	4,20,15,000	
March 03, 2008 <sup>#1</sup>	91	1000	6000	Preferential Allotment <sup>(45)</sup>	Cash	3,39,289	33,92,89,000	4,24,70,000	
March 08, 2008 <sup>#1</sup>	97	1000	6000	Preferential Allotment <sup>(46)</sup>	Cash	3,39,386	33,93,86,000	4,29,55,000	
March 11, 2008 <sup>#1</sup>	91	1000	6000	Preferential Allotment <sup>(47)</sup>	Cash	3,39,477	33,94,77,000	4,34,10,000	
March 12, 2008 <sup>#1</sup>	97	1000	6000	Preferential Allotment <sup>(48)</sup>	Cash	3,39,574	33,95,74,000	4,38,95,000	
March 14, 2008 <sup>#1</sup>	98	1000	6000	Preferential Allotment <sup>(49)</sup>	Cash	3,39,672	33,96,72,000	4,43,85,000	
March 18, 2008 <sup>#1</sup>	106	1000	6000	Preferential Allotment <sup>(50)</sup>	Cash	3,39,778	33,97,78,000	4,49,15,000	
March 25, 2008 <sup>#1</sup>	81	1000	6000	Preferential Allotment <sup>(51)</sup>	Cash	3,39,859	33,98,59,000	4,53,20,000	
March 31, 2008 <sup>#1</sup>	500	1000	6000	Preferential Allotment <sup>(52)</sup>	Cash	3,40,359	34,03,59,000	4,78,20,000	
May 13, 2010	Sub Division of the Face Value of the Equity Shares from ₹ 1000 to ₹ 10 each <sup>(53)</sup>						3,40,35,900	34,03,59,000	4,78,20,000



Date of Allotment of Equity Shares	No. of Equity Shares	Face Value (₹)	Issue Price (₹)	Nature / Reason of Allotment	Nature of Consideration	Cumulative No. of Equity Shares	Cumulative Paid Up Share Capital (₹)	Cumulative Share Premium (₹)
December 10, 2010 <sup>#2</sup>	5,20,100	10	200	Preferential Allotment <sup>(54)</sup>	Cash	3,45,56,000	34,55,60,000	14,66,39,000

<sup>#1</sup> Holders of equity shares allotted pursuant to these allotments and their subsequent transfers (“**Stated Shares**”) and / or pursuant to any corporate action on the Stated Shares (such as split of the face value of the Stated Shares or bonus issuances on the Stated Shares) were provided an Exit Opportunity (“**Exit Offer – 1**”) in accordance with the process as set forth in the SEBI circulars - CIR/CFD/DIL3/18/2015 dated December 31, 2015. For further details, please refer the chapter “**Risk Factors – We have in the past, made certain issuances and allotments of our equity shares which may not be in compliance with the applicable provisions and rules of the Companies Act, 1956.**” on page no. 17 of this Red Herring Prospectus.

<sup>#2</sup> Holders of equity shares allotted pursuant to these allotments and their subsequent transfers (“**Stated Transfers**”) were provided an Exit Opportunity (“**Exit Offer – 2**”) in accordance with the process as set forth in the SEBI circulars - CIR/CFD/DIL3/18/2015 dated December 31, 2015. For further details, please see “**Risk Factors – We have in the past, made certain issuances and allotments of our equity shares which may not be in compliance with the applicable provisions and rules of the Companies Act, 1956.**” on page no. 17 of this Red Herring Prospectus.

- 1) Allotment of 5 equity shares of face value of ₹ 1000 each to Umesh Katti , Babu Dhammanagi , Gurusiddappa Patil , Basavenappa Katti , Basavaraj Kappalguddhi , Shripalappa Munavalli and Ramappa Khemalapure as a result of subscription to the MoA.
- 2) 60,007 equity shares of face value of ₹ 1000 each were allotted to 4,238 allottees.
- 3) Allotment of equity shares of face value ₹ 1000; 3,020 Equity Shares to Rajeshwari Katti; 7,775 Equity Shares to Prakash Katti; 8,930 equity Shares to Ashok Utture; 7,400 Equity Shares to Riyaz Barger; 6,425 Equity Shares to Kashinath Utture; 4,640 Equity Shares to Ramesh Shiralkar and 2,005 Equity Shares to Mallikarjun Utture towards full satisfaction of compensation amount claimed by the owner of the land measuring 132 Acres 34 gunthas situated at Bellad Bagewadi, Taluka Hukkeri, District Belgaum acquired for the purpose of the setting up our manufacturing unit. For further details please refer to chapter titled “**Our Business - Property**” on page no. 151 of this Red Herring Prospectus.
- 4) 46, 467 equity shares of face value of ₹ 1000 each were allotted to Vishwanath Distilleries Limited.
- 5) 53,296 equity shares of face value of ₹ 1000 each were allotted to 47 allottees.
- 6) 41,570 equity shares of face value of ₹ 1000 each were allotted to 10 allottees.
- 7) 32,040 equity shares of face value of ₹ 1000 each were allotted to 22 allottees.

- 8) 23,615 equity shares of face value of ₹ 1000 each were allotted to 18 allottees.
- 9) Allotment of equity shares of face value of ₹ 1000; 400 Equity Shares to Shrikant Kundaragi, 200 Equity Shares to Mohammadyasin Kalaigar, 430 Equity Shares to Gurappa Katti, 250 Equity Shares to Siddappa Hagargi and 32,290 Equity Shares to Vishwanath Cogeneration Limited.
- 10) 174 equity shares of face value of ₹1000 were allotted to 48 allottees.
- 11) 184 equity shares of face value of ₹1000 were allotted to 48 allottees.
- 12) 179 equity shares of face value of ₹ 1000 were allotted to 48 allottees.
- 13) 192 equity shares of face value of ₹ 1000 were allotted to 48 allottees.
- 14) 196 equity shares of face value of ₹ 1000 were allotted to 49 allottees.
- 15) 192 equity shares of face value of ₹ 1000 were allotted to 48 allottees.
- 16) 195 equity shares of face value of ₹ 1000 were allotted to 48 allottees.
- 17) 240 equity shares of face value of ₹ 1000 were allotted to 48 allottees.
- 18) 240 equity shares of face value of ₹ 1000 were allotted to 48 allottees.
- 19) 220 equity shares of face value of ₹ 1000 were allotted to 48 allottees.
- 20) 177 equity shares of face value of ₹ 1000 were allotted to 48 allottees.
- 21) 210 equity shares of face value of ₹ 1000 were allotted to 48 allottees.
- 22) 1,105 equity shares of face value of ₹ 1000 were allotted to 48 allottees.
- 23) 1,225 equity shares of face value of ₹ 1000 were allotted to 48 allottees.
- 24) 842 equity shares of face value of ₹ 1000 were allotted to 48 allottees.
- 25) 169 equity shares of face value of ₹ 1000 were allotted to 48 allottees.
- 26) 162 equity shares of face value of ₹ 1000 were allotted to 48 allottees.
- 27) 157 equity shares of face value of ₹ 1000 were allotted to 48 allottees.
- 28) 158 equity shares of face value of ₹ 1000 were allotted to 48 allottees.
- 29) 166 equity shares of face value of ₹ 1000 were allotted to 48 allottees.
- 30) 171 equity shares of face value of ₹ 1000 were allotted to 48 allottees.
- 31) 167 equity shares of face value of ₹ 1000 were allotted to 48 allottees.
- 32) 274 equity shares of face value of ₹ 1000 were allotted to 48 allottees.
- 33) 55 equity shares of face value of ₹ 1000 were allotted to 9 allottees.
- 34) 157 equity shares of face value of ₹ 1000 were allotted to 49 allottees.
- 35) 132 equity shares of face value of ₹ 1000 were allotted to 49 allottees.
- 36) 115 equity shares of face value of ₹ 1000 were allotted to 49 allottees.

- 37) 142 equity shares of face value of ₹ 1000 were allotted to 49 allottees.
- 38) 132 equity shares of face value of ₹ 1000 were allotted to 49 allottees.
- 39) 134 equity shares of face value of ₹ 1000 were allotted to 49 allottees.
- 40) 136 equity shares of face value of ₹ 1000 were allotted to 49 allottees.
- 41) 121 equity shares of face value of ₹ 1000 were allotted to 49 allottees.
- 42) 115 equity shares of face value of ₹ 1000 were allotted to 49 allottees.
- 43) 94 equity shares of face value of ₹ 1000 were allotted to 49 allottees.
- 44) 75 equity shares of face value of ₹ 1000 were allotted to 42 allottees.
- 45) 91 equity shares of face value of ₹ 1000 were allotted to 37 allottees.
- 46) 97 equity shares of face value of ₹ 1000 were allotted to 49 allottees.
- 47) 91 equity shares of face value of ₹ 1000 were allotted to 49 allottees.
- 48) 97 equity shares of face value of ₹ 1000 were allotted to 49 allottees.
- 49) 98 equity shares of face value of ₹ 1000 were allotted to 49 allottees.
- 50) 106 equity shares of face value of ₹ 1000 were allotted to 49 allottees.
- 51) 81 equity shares of face value of ₹ 1000 were allotted to 49 allottees.
- 52) 500 equity shares of face value of ₹ 1000 were allotted to H. N. Nooli.
- 53) Pursuant to EGM held on May 13, 2010, our Company has subdivided the face value of the Equity Share from ₹ 1000/- to ₹ 10/- each.
- 54) 5,20,100 equity shares of face value of ₹ 10 were allotted to Umesh Katti in the capacity of Trustee of VSL Shareholders Welfare Trust.

## 2. Shares issued for consideration other than cash

Except as set out below, we have not issued Equity Shares for consideration other than cash or out of Revaluation Reserves:

Date of Allotment	Name of the Allottees	No. of Equity Shares	Face Value (₹)	Issue Price (₹)	Reasons for allotment	Benefits accrued to our Company
February 23, 2002	Mrs. Rajeshwari Katti	40,195	1000	NA	Allotment of shares towards compensation amount claimed by the owners of the land acquired for the purpose of the setting up our manufacturing unit.	Acquisition of land for setting up our Manufacturing Unit
	Mr. Prakash Katti					
	Mr. Ashok Utture					
	Mr. Riyaz Barger					
	Mr. Kashinath Utture					
	Mr. Ramesh Shiralkar					
	Mr. Mallikarjun Utture					

3. As on the date of this Red Herring Prospectus, our Company has not allotted any Equity Shares pursuant to any scheme approved under Sections 391 to 394 of the Companies Act, 1956 or under the provisions of Sections 230 to 240 of the Companies Act, 2013.

4. Our Company has not issued any Equity Shares out of revaluation reserves or unrealised profits.
5. No shares have been issued at a price lower than the Issue Price within the last one year from the date of this Red Herring Prospectus.

**6. Certain Issuances, Allotments and Transfers of Equity Shares in the past**

**a) Stated Shares**

During the period October 01, 2007 to March 31, 2008, our Company had made certain allotments wherein an aggregate of 9,564 Equity Shares of ₹ 1,000/- each (collectively, “the **Stated Shares**”) were allotted to 1,978 allottees. The said allotments were made in 43 different tranches, wherein the number of allottees was below the threshold limit of 50 in each individual allotment. These aggregate allotments of Stated Shares may not have been in compliance with the provisions governing a public offering of securities under the Companies Act, 1956, including those mandating the issuance and registration of a Prospectus.

**b) Stated Transfers**

In compliance with the applicable provisions of the Companies Act, 1956, we had allotted 5,20,100 Equity Shares of ₹ 10/- each to VSL Shareholders Welfare Trust on December 10, 2010. These shares were held by the trust for a period of around 3 years and subsequently transferred to 9,671 persons / farmers in FY 2013-14 (“**Stated Transfers**”) This resulted in an addition of 9,671 members in our Company. These Transferred Shares may not have been in compliance with the provisions governing a public offering of securities under the Companies Act, 1956, including those mandating the issuance and registration of a Prospectus.

**c) Details of VSL Shareholders Welfare Trust**

The VSL Shareholder Welfare Trust (the Trust) was formed on May 21, 2010 with the object of undertaking welfare activities for the farming community shareholders.

The details of the trustees of the Trust are:

Sr. No.	Name of the Trustee
1.	Mr. Umesh Katti
2.	Mr. Ramesh Katti
3.	Mr. Nikhil Katti
4.	Mr. Lava Katti
5.	Mr. Kush Katti

Out of the total available funds, the Trust invested in the shares of the Company and was allotted 5,20,100 Equity Shares of the Company aggregating to ₹ 1,040.20 lakhs on December 10, 2010. For details please see *Note 1* of the “*Capital Structure - Notes to Capital Structure*” on page no. 70 of this Red Herring Prospectus. The balance amounts were used primarily towards various educational and welfare activities of the farmers and other general purposes.

Subsequently, the trust transferred all its material assets (i.e. shares of Vishwaraj Sugar Industries Limited) back to its members on February 22, 2014 i.e. in the financial year 2013-14 and since then there has been no activity in the said trust.

The VSL Shareholders Welfare Trust was allotted 5,20,100 Equity Shares of the Company for a price of ₹ 200 per Share in December 2010 aggregating to ₹ 1,040.20 lakhs and the said amount was given by the members of the said Trust. Further, in the F. Y. 2013-14, these shares were transferred back to the individual farmers / members who had given the contribution on pro-rata basis at the same price i.e. ₹ 200 per share.

**d) Exit Offers**

The Offers were made in terms of SEBI Circular No. CIR/CFD/DIL3/18/2015 dated December 31, 2015 (“**SEBI Circular**”). Our Company had intimated to SEBI, Mumbai about the intention of the Exit Offers by the Acquirers via letter dated August 31, 2017.

### *Exit Offer – 1*

The allotments for the Stated Shares were made in different tranches, wherein the number of allottees was below the threshold limit of 50 in each allotment. Our Company has been given to understand that pursuant to the provisions of the then applicable Companies Act, and the recent judicial pronouncements, any invitation or offer to subscribe for shares made to 50 persons or more may be perceived as a Public Offer. Without prejudice and as a matter of abundant precaution, and in due compliance of the SEBI Circular, the Acquirers who are the Promoters of our Company have suo-moto volunteered to provide an Exit Offer of the said Stated Shares.

### *Exit Offer – 2*

The said allotment was made to one single entity and these shares were held by the trust for a period of around 3 years and subsequently transferred to 9,671 persons / farmers in FY 2013-14. Our Company has been given to understand that pursuant to the provisions of the then applicable Companies Act, and the recent judicial pronouncements, any invitation or offer to subscribe for shares made to 50 persons or more may be perceived as a Public Offer. Without prejudice and as a matter of abundant precaution, and in due compliance of the SEBI Circular, the Acquirers who are the Promoters of our Company have suo-moto volunteered to provide an Exit Offer to the current members of such Transferred Shares.

The Exit Offers were undertaken through the following steps:

- i. At its meeting on August 31, 2017, our Board approved the Exit Offers, and authorised Mr. Umesh Katti and Mr. Nikhil Katti, our Promoters (“**Acquirers**”), to provide the Exit Offers.
- ii. Venture Capital and Corporate Investments Private Limited (registered with SEBI as Registrar to an Issue and Transfer Agents) was appointed as the registrar to the Exit Offers (“**Exit Offer Registrar**”) through an agreement with the Acquirers dated August 16, 2017, to coordinate the Exit Offer processes. Yes Bank Limited (registered with SEBI as a Banker to an Issue) was appointed as escrow collection bank to the Exit Offers, through an agreement with the Acquirers and the Exit Offer Registrar dated August 23, 2017 and September 25, 2017, for the cash escrow account for the Exit Offers (“**Exit Offer Escrow Accounts**”). M/s. S. P. Ghali & Co, Company Secretaries (M. No. 7037) was also appointed to verify the list Eligible Shareholders.
- iii. The Acquirers and our Company decided the following –
  - the Exit Offer – 1 would be provided to all shareholders of our Company to whom Equity Shares were allotted in between October 01, 2007 to March 31, 2008 or current holders of such Equity Shares (“**Eligible Shareholders – 1**”)
  - the Exit Offer – 2 would be provided to all shareholders of our Company to whom Equity Shares were allotted on December 10, 2010 or current holders of such Equity Shares (“**Eligible Shareholders – 2**”).
- iv. Based on a review of our corporate records, M/s. S. P. Ghali & Co, Company Secretaries, verified that Eligible Shareholders – 1 are 1,156 and Eligible Shareholders - 2 are 9,663, vide its letter dated August 16, 2017 and September 29, 2017 respectively.
- v. The SEBI Circular provides that investors are to be given an exit offer at a price that is not less than the original subscription price along with 15% interest (or such higher returns promised to investors) from the date of subscription. Accordingly the offer price determined for Exit Offer – 1 was ₹ 150/- per Equity Share and for Exit Offer – 2 was ₹ 407/- per Equity Share.
- vi. Subsequently, Exit Offer letters dated September 05, 2017 for Exit Offer – 1 and September 30, 2017 for Exit Offer – 2 (“**Exit Offer Letters**”) were dispatched by the Exit Offer Registrar to all Eligible Shareholders – 1 and Eligible Shareholders – 2 respectively through registered post on September 06, 2017 and October 04, 2017.
- vii. An amount equivalent to 25% of the consideration each for the Exit Offer – 1 and Exit Offer – 2 was deposited in the respective Escrow Accounts by the Acquirers on September 05, 2017 and September 29, 2017.



viii. M/s. NSVR & Associates LLP, an independent CA, vide their certificates dated November 20, 2017, certified that as Exit Offer – 1 received response from 80 Eligible Shareholders who tendered 30,100 Equity Shares and Exit Offer – 2 received response from 414 Eligible Shareholders who tendered 22,750 Equity Shares. All the tendered shares were accepted and none of the shares was rejected.

**e) Compounding and Settlement**

Apart from providing the Exit Offers through the Acquirers, we had filed, on December 19, 2017, an application with the Registrar of Companies, Bangalore (“RoC”) (also enclosing a compounding petition to the NCLT or the Regional Director) seeking to compound these breaches of Companies Act, 1956 occasioned by the Stated Shares and the Transferred Shares. By an order dated October 31, 2018, the Hon’ble NCLT (Bengaluru Bench) rejected our petition due to it being premature and leaving the matter to SEBI to decide the issue in accordance with law at the appropriate time. Further, there was no order as to costs.

**f) Details of any pending investor complaints**

There are no pending investor complaints as regards to the Stated Shares and the Transferred Shares as on the date of this Red Herring Prospectus. Further, our Acquirer Promoters confirms that they will continue to address any future complaints by any shareholder pertaining to the Exit Offers.

**7. History of the Equity Share Capital held by our Promoters**

As on the date of this Red Herring Prospectus, our Promoters hold 1,17,34,750 Equity Shares, constituting 33.96% of the issued, subscribed and paid-up Equity Share capital of our Company. The details regarding our Promoters shareholding is set out below:

Date of allotment/ transfer	Nature of transaction	Number of equity shares	Nature of consideration	Face value (₹)	Issue / acquisition / transfer price per equity share (₹)	% of the pre-Offer equity share capital	% of the post-Offer equity share capital	Lock in Period
<b>MR. UMESH KATTI</b>								
On Incorporation	Subscription to MOA	5 <sup>(1)</sup>	Cash	1000	1000	0.00%	0.00%	3 Years
March 28, 2003	Allotment	100 <sup>(1)</sup>	Cash	1000	1000	0.03%	0.03%	3 Years
September 02, 2003	Allotment	1,400 <sup>(1)</sup>	Cash	1000	1000	0.41%	0.37%	3 Years
January 19, 2008	Transfer	5 <sup>(1)</sup>	Cash	1000	1000	0.00%	0.00%	3 Years
July 29, 2009	Transfer	7,990 <sup>(1)</sup>	Cash	1000	1000	3.11%	2.87%	3 Years
		2,771						1 Year
Pursuant to a resolution of our shareholders dated May 13, 2010, each equity share of our Company of face value ₹ 1000 was sub divided into the face value of ₹ 10 each, and accordingly, 12,271 equity shares of ₹ 1000 each held Umesh Katti were split into 12,27,100 Equity Shares.								
June 02, 2010	Transfer	35,500	Cash	10	10	0.10%	0.09%	1 Year
February 15, 2011	Transmission	1,39,875	Cash	10	-	0.40%	0.37%	1 Year
September 25, 2017	Acquired through Exit Offer -1	10,000	Cash	10	150	0.03%	0.03%	1 Year
October 25, 2017	Acquired through Exit Offer - 2	6,100	Cash	10	407	0.02%	0.02%	1 Year

<sup>(1)</sup> 9,50,000 Equity Shares of Mr. Umesh Katti will be locked-in for a period of three years and remaining for a period of one year.

Date of allotment/ transfer	Nature of transaction	Number of equity shares	Nature of consideration	Face value (₹)	Issue/ acquisition/ transfer price per equity share (₹)	% of the pre-Offer equity share capital	% of the post-Offer equity share capital	Lock in Period
<b>MR. RAMESH KATTI</b>								
October 28, 2004	Allotment	50 <sup>(1)</sup>	Cash	1000	1000	0.01%	0.01%	3 Years
July 29, 2009	Transfer	8,860 <sup>(1)</sup>	Cash	1000	1000	3.46%	3.18%	3 Years
		3,092						1 Year
Pursuant to a resolution of our shareholders dated May 13, 2010, each equity share of our Company of face value ₹ 1000 was sub divided into the face value of ₹ 10 each, and accordingly, 12,002 equity shares of ₹ 1000 each held Ramesh Katti were split into 12,00,200 Equity Shares.								
June 02, 2010	Transfer	35,500	Cash	10	10	0.10%	0.09%	1 Year
February 15, 2011	Transmission	93,250	Cash	10	-	0.27%	0.25%	1 Year

<sup>(1)</sup> 8,91,000 Equity Shares of Mr. Ramesh Katti will be locked-in for a period of three years and remaining for a period of one year.

Date of allotment/ transfer	Nature of transaction	Number of equity shares	Nature of consideration	Face value (₹)	Issue/ acquisition/ transfer price per equity share (₹)	% of the pre-Offer equity share capital	% of the post-Offer equity share capital	Lock in Period
<b>MRS. SHEELA KATTI</b>								
October 28, 2004	Allotment	50 <sup>(1)</sup>	Cash	1000	1000	0.01%	0.01%	3 Years
July 29, 2009	Transfer	7,600 <sup>(1)</sup>	Cash	1000	1000	3.25%	2.99%	3 Years
		3,630						1 Year
Pursuant to a resolution of our shareholders dated May 13, 2010, each equity share of our Company of face value ₹ 1000 was sub divided into the face value of ₹ 10 each, and accordingly, 11,280 equity shares of ₹ 1000 each held Sheela Katti were split into 11,28,000 Equity Shares.								
June 04, 2010	Transfer	13,000	Cash	10	10	0.04%	0.03%	1 Year

<sup>(1)</sup> 7,65,000 Equity Shares of Mrs. Sheela Katti will be locked-in for a period of three years and remaining for a period of one year.

Date of allotment/ transfer	Nature of transaction	Number of equity shares	Nature of consideration	Face value (₹)	Issue/ acquisition/ transfer price per equity share (₹)	% of the pre-Offer equity share capital	% of the post-Offer equity share capital	Lock in Period
<b>MRS. JAYASHREE KATTI</b>								
October 28, 2004	Allotment	50 <sup>(1)</sup>	Cash	1000	1000	0.01%	0.01%	3 Years
July 29, 2009	Transfer	8,390 <sup>(1)</sup>	Cash	1000	1000	3.59%	3.31%	3 Years
		4,023						1 Year
Pursuant to a resolution of our shareholders dated May 13, 2010, each equity share of our Company of face value ₹ 1000 was sub divided into the face value of ₹ 10 each, and accordingly, 12,463 equity shares of ₹ 1000 each held Jayashree Katti were split into 12,46,300 Equity Shares.								
June 04, 2010	Transfer	12,500	Cash	10	10	0.04%	0.03%	1 Year

<sup>(1)</sup> 8,44,000 Equity Shares of Mrs. Jayashree Katti will be locked-in for a period of three years and remaining for a period of one year.

Date of allotment/ transfer	Nature of transaction	Number of equity shares	Nature of consideration	Face value (₹)	Issue/ acquisition/ transfer price per equity share (₹)	% of the pre- Offer equity share capital	% of the post- Offer equity share capital	Lock in Period
<b>MR. NIKHIL KATTI</b>								
October 28, 2004	Allotment	50 <sup>(1)</sup>	Cash	1000	1000	0.01%	0.01%	N.A <sup>(1)</sup>
June 15, 2005	Transfer	10 <sup>(1)</sup>	Cash	1000	1000	0.00%	0.00%	N.A <sup>(1)</sup>
June 21, 2007	Transfer	10 <sup>(1)</sup>	Cash	1000	1000	0.00%	0.00%	N.A <sup>(1)</sup>
July 29, 2009	Transfer	1,930 <sup>(1)</sup>	Cash	1000	1000	3.96%	3.65%	N.A <sup>(1)</sup>
		11,770 <sup>(2)</sup>						3 Years
Pursuant to a resolution of our shareholders dated May 13, 2010, each equity share of our Company of face value ₹ 1000 was sub divided into the face value of ₹ 10 each, and accordingly, 13,770 equity shares of ₹ 1000 each held Nikhil Katti were split into 13,77,000 Equity Shares.								
June 04, 2010	Transfer	25,000 <sup>(2)</sup>	Cash	10	10	0.07%	0.07%	3 Years
November 05, 2010	Transfer	4,98,550 <sup>(2)</sup>	Cash	10	10	1.44%	1.33%	3 Years
February 15, 2011	Transfer	1,40,375 <sup>(2)</sup>	Cash	10	10	0.41%	0.37%	3 Years
September 01, 2013	Transfer	5,01,075 <sup>(2)</sup>	Cash	10	10	4.67%	4.30%	3 Years
		11,14,125						1 Year
September 25, 2017	Acquired through Exit Offer -1	20,100	Cash	10	150	0.06%	0.05%	1 Year
October 25, 2017	through Exit Offer - 2	16,650	Cash	10	407	0.05%	0.04%	1 Year

<sup>(1)</sup> Out of total holding of Mr. Nikhil Katti, shares aggregating to 2,00,000 equity shares are offered through this Red Herring Prospectus.

<sup>(2)</sup> 23,42,000 Equity Shares of Mr. Nikhil Katti will be locked-in for a period of three years and remaining for a period of one year.

Date of allotment/ transfer	Nature of transaction	Number of equity shares	Nature of consideration	Face value (₹)	Issue/ acquisition/ transfer price per equity share (₹)	% of the pre- Offer equity share capital	% of the post- Offer equity share capital	Lock in Period
<b>MR. LAVA KATTI</b>								
July 29, 2009	Transfer	1,000 <sup>(1)</sup>	Cash	1000	1000	1.73%	1.59%	N.A <sup>(1)</sup>
		4,966 <sup>(2)</sup>						3 Years
Pursuant to a resolution of our shareholders dated May 13, 2010, each equity share of our Company of face value ₹ 1000 was sub divided into the face value of ₹ 10 each, and accordingly, 5,966 equity shares of ₹ 1000 each held Lava Katti were split into 5,96,600 Equity Shares.								
June 04, 2010	Transfer	12,500 <sup>(2)</sup>	Cash	10	10	0.04%	0.03%	3 Years
November 05, 2010	Transfer	2,28,900 <sup>(2)</sup>	Cash	10	10	1.44%	1.33%	3 Years
		2,69,025						1 Year
February 15, 2011	Transfer	93,250	Cash	10	10	0.27%	0.25%	1 Year

<sup>(1)</sup> Out of total holding of Mr. Lava Katti, shares aggregating to 1,00,000 equity shares are offered through this Red Herring Prospectus.

<sup>(2)</sup> 7,38,000 Equity Shares of Mr. Lava Katti will be locked-in for a period of three years and remaining for a period of one year.

Date of allotment/transfer	Nature of transaction	Number of equity shares	Nature of consideration	Face value (₹)	Issue/acquisition/transfer price per equity share (₹)	% of the pre-Offer equity share capital	% of the post-Offer equity share capital	Lock in Period
<b>MR. KUSH KATTI</b>								
July 29, 2009	Transfer	1,000 <sup>(1)</sup>	Cash	1000	1000	1.86%	1.72%	N.A <sup>(1)</sup>
		5,444 <sup>(2)</sup>						3 Years
Pursuant to a resolution of our shareholders dated May 13, 2010, each equity share of our Company of face value ₹ 1000 was sub divided into the face value of ₹ 10 each, and accordingly, 6,444 equity shares of ₹ 1000 each held Lava Katti were split into 6,44,400 Equity Shares.								
June 04, 2010	Transfer	9,500 <sup>(2)</sup>	Cash	10	10	0.03%	0.03%	3 Years
November 05, 2010	Transfer	2,14,100 <sup>(2)</sup>	Cash	10	10	1.44%	1.33%	3 Years
		2,83,825						1 Year
February 15, 2011	Transfer	93,250	Cash	10	10	0.27%	0.25%	1 Year

<sup>(1)</sup> Out of total holding of Mr. Kush Katti, shares aggregating to 1,00,000 equity shares are offered through this Red Herring Prospectus.

<sup>(2)</sup> 7,68,000 Equity Shares of Mr. Lava Katti will be locked-in for a period of three years and remaining for a period of one year.

Date of allotment/transfer	Nature of transaction	Number of equity shares	Nature of consideration	Face value (₹)	Issue/acquisition/transfer price per equity share (₹)	% of the pre-Offer equity share capital	% of the post-Offer equity share capital	Lock in Period
<b>MRS. SNEHA NITHIN DEV</b>								
July 29, 2009	Transfer	3,020 <sup>(1)</sup>	Cash	1000	1000	1.30%	1.20%	3 Years
		1,472						1 Year
Pursuant to a resolution of our shareholders dated May 13, 2010, each equity share of our Company of face value ₹ 1000 was sub divided into the face value of ₹ 10 each, and accordingly, 4,492 equity shares of ₹ 1000 each held Sneha Nithin Dev were split into 4,49,200 Equity Shares.								

<sup>(1)</sup> 3,02,000 Equity Shares of Mrs. Sneha Nithin Dev will be locked-in for a period of three years and remaining for a period of one year.

## 8. Shareholding of our Promoters and the members of our Promoter Group

Provided below are details of Equity Shares held by our Promoters and the members of our Promoter Group as on the date of this Red Herring Prospectus:

Sr. No.	Name of Shareholder	Pre-Offer		Post-Offer	
		No. of Equity Shares	Percentage of pre-offer capital (%)	No. of Equity Shares	Percentage of post-offer capital (%)
<b>A. Promoters</b>					
1	Umesh Katti	14,18,575	4.11%	14,18,575	3.78%
2	Ramesh Katti	13,28,950	3.85%	13,28,950	3.54%
3	Sheela Katti	11,41,000	3.30%	11,41,000	3.04%
4	Jayashree Katti	12,58,800	3.64%	12,58,800	3.35%
5	Nikhil Katti	36,92,875	10.69%	34,92,875	9.30%
6	Lava Katti	12,00,275	3.47%	11,00,275	2.93%
7	Kush Katti	12,45,075	3.60%	11,45,075	3.05%
8	Sneha Nithin Dev	4,49,200	1.30%	4,49,200	1.20%
<b>Sub-Total (A)</b>		<b>1,17,34,750</b>	<b>33.96%</b>	<b>1,13,34,750</b>	<b>30.18%</b>
<b>B. Promoter Group (as per defined by Reg. 2(1)(zb)(ii) &amp; (iv) of SEBI ICDR Regulations)</b>					

Sr. No.	Name of Shareholder	Pre-Offer		Post-Offer	
		No. of Equity Shares	Percentage of pre-offer capital (%)	No. of Equity Shares	Percentage of post-offer capital (%)
1	Purnima Pangi	5,000	0.01%	Nil	N. A.
2	Satish Ghuli	2,000	0.00%	1,000	0.00%
3	Suhas Ghuli	2,000	0.00%	1,000	0.00%
4	Yuvaraj Chunamuri	2,000	0.00%	1,000	0.00%
5	Shailaja Uchale	1,000	0.00%	Nil	N. A.
6	Channavva Chunamure	1,000	0.00%	Nil	N. A.
7	Shanmukhappa Chunamure	1,000	0.00%	Nil	N. A.
8	Drakashayani Katti	3,500	0.01%	Nil	N. A.
9	Kalavati Savadakar	1,000	0.00%	Nil	N. A.
<b>Sub-Total (B)</b>		<b>18,500</b>	<b>0.05%</b>	<b>3,000</b>	<b>0.01%</b>
<b>C. Promoter Group (as per defined by Reg. 2(1)(zb)(v) of SEBI ICDR Regulations)</b>					
1	Ashok Utture	10,29,300	2.98%	Nil	N. A.
2	Kashinath Utture	6,81,000	1.97%	Nil	N. A.
3	Kadayya Pujar	6,43,550	1.86%	Nil	N. A.
4	Basavaraj Pujar	6,39,600	1.85%	Nil	N. A.
5	Ramappa Khemlapure	5,37,000	1.55%	Nil	N. A.
6	Ramesh Shiralakar	5,00,650	1.45%	2,300	0.01%
7	Sudhir Katti	4,00,700	1.16%	Nil	N. A.
8	Ramappa Bani	3,40,850	0.99%	Nil	N. A.
9	Ravindra Katti	4,97,900	1.44%	4,97,900	1.33%
10	Muragesh Katti	3,21,500	0.93%	Nil	N. A.0.00%
11	Kallapa Bani	2,97,500	0.86%	Nil	N. A.
12	Abhinandan Khempapure	2,75,500	0.80%	2,75,500	0.73%
13	Rajaram Shiralkar	2,63,400	0.76%	Nil	N. A.
14	Basavraj Utture	2,11,100	0.61%	2,11,100	0.56%
15	Gurappa Katti	1,65,850	0.48%	Nil	N. A.
16	Vinod Katti	1,57,550	0.46%	Nil	N. A.
17	Padmaja Katti	10,000	0.03%	5,000	N. A.
18	Pallavi Ghuli	1,000	0.00%	Nil	N. A.
19	Tejasvini Chunamuri	1,000	0.00%	Nil	N. A.
20	Prachi Ghuli	1,000	0.00%	Nil	N. A.
21	Sanjay Khemalapur	4,900	0.01%	Nil	N. A.
22	Sudharshan Khemalapur	1,500	0.00%	Nil	N. A.
<b>Sub-Total (C)</b>		<b>69,82,350</b>	<b>20.21%</b>	<b>9,91,800</b>	<b>2.64%</b>
<b>TOTAL (A+B+C)</b>		<b>1,87,35,600</b>	<b>54.22%</b>	<b>1,23,29,550</b>	<b>32.83%</b>

All Equity Shares held by the Promoters and members of our Promoter Group have been dematerialised as on date of this Red Herring Prospectus.

## 9. History of the Equity Share Capital held by the Selling Shareholders

The details of the build-up of Equity Shares offered for the Offer for Sale by the respective Selling Shareholders is as given below:

For details of build-up of our Promoter Selling shareholders, please see “History of the Equity Share Capital held by our Promoters – Capital Structure” on page no. 79 of this Red Herring Prospectus.

### • Details of the share capital held by Mr. Ashok Utture

Date of Allotment / Transfer	Nature of Transaction	Consideration	No. of Shares	Face Value (₹)	Issue Price / Transfer Price (₹)	Cumulative no. of Shares
December 11, 2000	Allotment	Cash	15	1,000	1,000	15



February 23, 2002	Allotment	Other Than Cash	8,930	1,000	1,000	8,945
March 28, 2003	Preferential Allotment	Cash	485	1,000	1,000	9,430
October 28, 2004	Preferential Allotment	Cash	825	1,000	1,000	10,255
October 16, 2007	Preferential Allotment	Cash	4	1,000	6,000	10,259
December 30, 2007	Preferential Allotment	Cash	4	1,000	6,000	10,263
July 29, 2009	Transfer	Cash	30	1,000	1,000	10,293 <sup>(1)</sup>

Pursuant to a resolution of our shareholders dated May 13, 2010, each equity share of our Company of face value ₹ 1,000 was sub divided into the face value of ₹ 10 each, and accordingly, 10,293 equity shares of ₹ 1,000 each held by Ashok Utture were split into 10,29,300 Equity Shares<sup>(1)</sup>.

<sup>(1)</sup> The entire holding of Ashok Utture i.e. 10,29,300 equity shares are offered as a part of Offer of Sale.

- **Details of the share capital held by Riyaz Bargeer**

Date of Allotment / Transfer	Nature of Transaction	Consideration	No. of Shares	Face Value (₹)	Issue Price / Transfer Price (₹)	Cumulative no. of Shares
February 23, 2002	Allotment	Other than Cash	7,400	1,000	-	7,400
March 28, 2003	Preferential Allotment	Cash	480	1,000	1,000	7,880
October 06, 2007	Preferential Allotment	Cash	7	1,000	6,000	7,887
October 11, 2007	Preferential Allotment	Cash	4	1,000	6,000	7,891 <sup>(1)</sup>

Pursuant to a resolution of our shareholders dated May 13, 2010, each equity share of our Company of face value ₹ 1,000 was sub divided into the face value of ₹ 10 each, and accordingly, 7,891 equity shares of ₹ 1,000 each held by Riyaz Bargeer were split into 7,89,100 Equity Shares<sup>(1)</sup>.

<sup>(1)</sup> Out of the total holding of Riyaz Bargeer, 5,56,950 equity shares are offered as a part of Offer of Sale.

- **Details of the share capital held by Kashinath Utture**

Date of Allotment / Transfer	Nature of Transaction	Consideration	No. of Shares	Face Value (₹)	Issue Price / Transfer Price (₹)	Cumulative no. of Shares
December 11, 2000	Preferential Allotment	Cash	10	1,000	1,000	10
February 23, 2002	Preferential Allotment	Other Than Cash	6,425	1,000	1,000	6,435
March 28, 2003	Preferential Allotment	Cash	370	1,000	1,000	6,805
November 15, 2007	Preferential Allotment	Cash	5	1,000	6,000	6,810 <sup>(1)</sup>

Pursuant to a resolution of our shareholders dated May 13, 2010, each equity share of our Company of face value ₹ 1,000 was sub divided into the face value of ₹ 10 each, and accordingly, 6,810 equity shares of ₹ 1,000 each held by Kashinath Utture were split into 6,81,000 Equity Shares<sup>(1)</sup>.

<sup>(1)</sup> The entire holding of Ashok Utture i.e. 6,81,000 equity shares are offered as a part of Offer of Sale.

- **Details of the share capital held by Kadayya Pujar**

Date of Allotment / Transfer	Nature of Transaction	Consideration	No. of Shares	Face Value (₹)	Issue Price / Transfer Price (₹)	Cumulative no. of Shares
December 11,	Preferential	Cash	90	1,000	1,000	90

2000	Allotment					
September 02, 2003	Preferential Allotment	Cash	2,100	1,000	1,000	2,190
October 28, 2004	Preferential Allotment	Cash	2,115	1,000	1,000	4,305
December 27, 2004	Preferential Allotment	Cash	2,105	1,000	1,000	6,410
July 29, 2009	Transfer	Cash	25	1,000	1,000	6,435
Pursuant to a resolution of our shareholders dated May 13, 2010, each equity share of our Company of face value ₹ 1,000 was sub divided into the face value of ₹ 10 each, and accordingly, 6,435 equity shares of ₹ 1,000 each held by Kadayya Pujar were split into 6,43,500 Equity Shares.						
February 22, 2014	Transfer	Cash	50	10	200	6,43,550 <sup>(1)</sup>

<sup>(1)</sup> The entire holding of Kadayya Pujar i.e. 6,43,550 equity shares are offered as a part of Offer of Sale.

- **Details of the share capital held by Basavaraj Pujar**

Date of Allotment / Transfer	Nature of Transaction	Consideration	No. of Shares	Face Value (₹)	Issue Price / Transfer Price (₹)	Cumulative no. of Shares
December 11, 2000	Preferential Allotment	Cash	135	1,000	1,000	135
March 28, 2003	Preferential Allotment	Cash	1,025	1,000	1,000	1,160
September 02, 2003	Preferential Allotment	Cash	3,260	1,000	1,000	4,420
December 27, 2004	Preferential Allotment	Cash	1,950	1,000	1,000	6,370
December 30, 2007	Preferential Allotment	Cash	4	1,000	6,000	6,374
January 14, 2008	Preferential Allotment	Cash	4	1,000	6,000	6,378
January 14, 2008	Transfer	Cash	(8)	1,000	1,000	6,395
July 29, 2009	Transfer	Cash	25	1,000	1,000	6,403
Pursuant to a resolution of our shareholders dated May 13, 2010, each equity share of our Company of face value ₹ 1,000 was sub divided into the face value of ₹ 10 each, and accordingly, 6,395 equity shares of ₹ 1,000 each held by Basavaraj Pujar were split into 6,39,500 Equity Shares.						
February 22, 2014	Transfer	Cash	100	10	200	6,39,600 <sup>(1)</sup>

<sup>(1)</sup> The entire holding of Basavaraj Pujar i.e. 6,39,600 equity shares are offered as a part of Offer of Sale.

- **Details of the share capital held by Rammappa Khemalpure**

Date of Allotment / Transfer	Nature of Transaction	Consideration	No. of Shares	Face Value (₹)	Issue Price / Transfer Price (₹)	Cumulative no. of Shares
On Incorporation	Subscription to MOA	Cash	5	1,000	1,000	5
September 02, 2003	Allotment	Cash	5,365	1,000	1,000	5,370 <sup>(1)</sup>
Pursuant to a resolution of our shareholders dated May 13, 2010, each equity share of our Company of face value ₹ 1,000 was sub divided into the face value of ₹ 10 each, and accordingly, 5,370 equity shares of ₹ 1,000 each held by Rammappa Khemalpure were split into 5,37,000 Equity Shares <sup>(1)</sup> .						

<sup>(1)</sup> The entire holding of Rammappa Khemalpure i.e. 5,37,000 equity shares are offered as a part of Offer of Sale.

- **Details of the share capital held by Ramesh Shiralakar**

Date of Allotment / Transfer	Nature of Transaction	Consideration	No. of Shares	Face Value (₹)	Issue Price / Transfer Price (₹)	Cumulative no. of Shares
February 23, 2002	Preferential Allotment	Other Than Cash	4,640	1,000	1,000	4,640
March 28, 2003	Preferential Allotment	Cash	325	1,000	1,000	4,965
October 31, 2007	Preferential Allotment	Cash	4	1,000	6,000	4,969
November 25, 2007	Preferential Allotment	Cash	4	1,000	6,000	4,973
February 02, 2008	Preferential Allotment	Cash	3	1,000	6,000	4,976
February 20, 2008	Preferential Allotment	Cash	4	1,000	6,000	4,980
February 22, 2008	Preferential Allotment	Cash	3	1,000	6,000	4,983
February 23, 2008	Preferential Allotment	Cash	3	1,000	6,000	4,986
February 25, 2008	Preferential Allotment	Cash	3	1,000	6,000	4,989
February 27, 2008	Preferential Allotment	Cash	3	1,000	6,000	4,992
February 28, 2008	Preferential Allotment	Cash	3	1,000	6,000	4,995
February 29, 2008	Preferential Allotment	Cash	3	1,000	6,000	4,998
March 03, 2008	Preferential Allotment	Cash	3	1,000	6,000	5,001
March 08, 2008	Preferential Allotment	Cash	2	1,000	6,000	5,003
March 18, 2008	Preferential Allotment	Cash	3	1,000	6,000	5,006
Pursuant to a resolution of our shareholders dated May 13, 2010, each equity share of our Company of face value ₹ 1,000 was sub divided into the face value of ₹ 10 each, and accordingly, 5,006 equity shares of ₹ 1,000 each held by Ramesh Shiralakar were split into 5,00,600 Equity Shares.						
February 22, 2014	Transfer	Cash	50	10	200	5,00,650 <sup>(1)</sup>

<sup>(1)</sup> Out of the total holding of Ramesh Shiralakar, 4,98,350 equity shares are offered as a part of Offer of Sale.

- **Details of the share capital held by Sudhir Katti**

Date of Allotment / Transfer	Nature of Transaction	Consideration	No. of Shares	Face Value (₹)	Issue Price / Transfer Price (₹)	Cumulative no. of Shares
December 11, 2000	Preferential Allotment	Cash	100	1,000	1,000	100
March 28, 2003	Preferential Allotment	Cash	1,035	1,000	1,000	1,135
October 28, 2004	Preferential Allotment	Cash	1,215	1,000	1,000	2,350
December 27, 2004	Preferential Allotment	Cash	1,870	1,000	1,000	4,220
October 01, 2007	Preferential Allotment	Cash	3	1,000	6,000	4,223
October 06,	Preferential	Cash	4	1,000	6,000	4,227

2007	Allotment					
October 11, 2007	Preferential Allotment	Cash	8	1,000	6,000	4,235
November 05, 2007	Preferential Allotment	Cash	5	1,000	6,000	4,240
November 25, 2007	Preferential Allotment	Cash	4	1,000	6,000	4,244
January 09, 2008	Preferential Allotment	Cash	4	1,000	6,000	4,248
February 13, 2008	Preferential Allotment	Cash	3	1,000	6,000	4,251
February 18, 2008	Preferential Allotment	Cash	3	1,000	6,000	4,254
February 22, 2008	Preferential Allotment	Cash	3	1,000	6,000	4,257
Pursuant to a resolution of our shareholders dated May 13, 2010, each equity share of our Company of face value ₹ 1,000 was sub divided into the face value of ₹ 10 each, and accordingly, 4,257 equity shares of ₹ 1,000 each held by Sudhir Katti were split into 4,25,700 Equity Shares.						
August 26, 2016	Transfer	Cash	(25,000)	10	10	4,00,700 <sup>(1)</sup>

<sup>(1)</sup> The entire holding of Sudhir Katti i.e. 4,00,700 equity shares are offered as a part of Offer of Sale.

- **Details of the share capital held by Ramappa Bani**

Date of Allotment / Transfer	Nature of Transaction	Consideration	No. of Shares	Face Value (₹)	Issue Price / Transfer Price (₹)	Cumulative no. of Shares
December 11, 2000	Preferential Allotment	Cash	60	1,000	1,000	60
March 28, 2003	Preferential Allotment	Cash	1,230	1,000	1,000	1,290
December 27, 2004	Preferential Allotment	Cash	2,350	1,000	1,000	3,640
December 05, 2007	Preferential Allotment	Cash	35	1,000	6,000	3,675
March 18, 2008	Preferential Allotment	Cash	1	1,000	6,000	3,676
Pursuant to a resolution of our shareholders dated May 13, 2010, each equity share of our Company of face value ₹ 1,000 was sub divided into the face value of ₹ 10 each, and accordingly, 3,676 equity shares of ₹ 1,000 each held by Ramappa Bani were split into 3,67,600 Equity Shares.						
October 10, 2016	Transfer	Cash	(26,750)	10	10	3,40,850 <sup>(1)</sup>

<sup>(1)</sup> The entire holding of Ramappa Bani i.e. 3,40,850 equity shares are offered as a part of Offer of Sale.

- **Details of the share capital held by Muragesh Katti**

Date of Allotment / Transfer	Nature of Transaction	Consideration	No. of Shares	Face Value (₹)	Issue Price / Transfer Price (₹)	Cumulative no. of Shares
December 11, 2000	Preferential Allotment	Cash	25	1,000	1,000	25
March 28, 2003	Preferential Allotment	Cash	1,645	1,000	1,000	1,670
October 28, 2004	Preferential Allotment	Cash	1,460	1,000	1,000	3,130
December 05, 2007	Preferential Allotment	Cash	35	1,000	6,000	3,165
February 20,	Preferential	Cash	3	1,000	6,000	3,168

2008	Allotment					
February 23, 2008	Preferential Allotment	Cash	3	1,000	6,000	3,171
February 25, 2008	Preferential Allotment	Cash	3	1,000	6,000	3,174
February 27, 2008	Preferential Allotment	Cash	3	1,000	6,000	3,177
February 29, 2008	Preferential Allotment	Cash	3	1,000	6,000	3,180
March 03, 2008	Preferential Allotment	Cash	6	1,000	6,000	3,186
March 08, 2008	Preferential Allotment	Cash	1	1,000	6,000	3,187
March 18, 2008	Preferential Allotment	Cash	3	1,000	6,000	3,190
July 29, 2009	Transfer	Cash	25	1,000	1,000	3,215 <sup>(1)</sup>

Pursuant to a resolution of our shareholders dated May 13, 2010, each equity share of our Company of face value ₹ 1,000 was sub divided into the face value of ₹ 10 each, and accordingly, 3,215 equity shares of ₹ 1,000 each held by Muragesh Katti were split into 3,21,500 Equity Shares<sup>(1)</sup>.

<sup>(1)</sup> The entire holding of Muragesh Katti i.e. 3,21,500 equity shares are offered as a part of Offer of Sale.

- **Details of the share capital held by Kallapa Bani**

Date of Allotment / Transfer	Nature of Transaction	Consideration	No. of Shares	Face Value (₹)	Issue Price / Transfer Price (₹)	Cumulative no. of Shares
December 11, 2000	Preferential Allotment	Cash	60	1,000	1,000	60
December 27, 2004	Preferential Allotment	Cash	2,870	1,000	1,000	2,930
November 30, 2007	Preferential Allotment	Cash	43	1,000	6,000	2,973
March 14, 2008	Preferential Allotment	Cash	2	1,000	6,000	2,975

Pursuant to a resolution of our shareholders dated May 13, 2010, each equity share of our Company of face value ₹ 1,000 was sub divided into the face value of ₹ 10 each, and accordingly, 2,975 equity shares of ₹ 1,000 each held by Kallapa Bani were split into 2,97,500 Equity Shares<sup>(1)</sup>.

<sup>(1)</sup> The entire holding of Kallapa Bani i.e. 2,97,500 equity shares are offered as a part of Offer of Sale.

- **Details of the share capital held by Rajaram Shiralkar**

Date of Allotment / Transfer	Nature of Transaction	Consideration	No. of Shares	Face Value (₹)	Issue Price / Transfer Price (₹)	Cumulative no. of Shares
December 11, 2000	Preferential Allotment	Cash	148	1,000	1,000	148
March 28, 2004	Preferential Allotment	Cash	2,475	1,000	1,000	2,623
October 16, 2007	Preferential Allotment	Cash	4	1,000	6,000	2,627
January 09, 2008	Preferential Allotment	Cash	4	1,000	6,000	2,631
March 18, 2008	Preferential Allotment	Cash	3	1,000	6,000	2,634 <sup>(1)</sup>

Pursuant to a resolution of our shareholders dated May 13, 2010, each equity share of our Company of face value ₹ 1,000 was sub divided into the face value of ₹ 10 each, and accordingly, 2,634 equity shares of ₹ 1,000 each held by Rajaram Shiralkar were split into 2,63,400 Equity Shares<sup>(1)</sup>.

<sup>(1)</sup> The entire holding of Rajaram Shiralkar i.e. 2,63,400 equity shares are offered as a part of Offer of Sale.



- Details of the share capital held by Gurappa Katti

Date of Allotment / Transfer	Nature of Transaction	Consideration	No. of Shares	Face Value (₹)	Issue Price / Transfer Price (₹)	Cumulative no. of Shares
December 11, 2000	Preferential Allotment	Cash	20	1,000	1,000	20
March 28, 2003	Preferential Allotment	Cash	1,190	1,000	1,000	1,210
March 29, 2003	Transfer	Cash	5	1,000	1,000	1,215
August 08, 2005	Preferential Allotment	Cash	430	1,000	1,000	1,645
November 15, 2007	Preferential Allotment	Cash	5	1,000	6,000	1,650
December 05, 2007	Preferential Allotment	Cash	4	1,000	6,000	1,654
January 09, 2008	Preferential Allotment	Cash	4	1,000	6,000	1,658
Pursuant to a resolution of our shareholders dated May 13, 2010, each equity share of our Company of face value ₹ 1,000 was sub divided into the face value of ₹ 10 each, and accordingly, 1,658 equity shares of ₹ 1,000 each held by Gurappa Katti were split into 1,65,800 Equity Shares.						
February 22, 2014	Transfer	Cash	50	10	200	1,65,850 <sup>(1)</sup>

<sup>(1)</sup> The entire holding of Gurappa Katti i.e. 1,65,850 equity shares are offered as a part of Offer of Sale.

- Details of the share capital held by Vinod Katti

Date of Allotment / Transfer	Nature of Transaction	Consideration	No. of Shares	Face Value (₹)	Issue Price / Transfer Price (₹)	Cumulative no. of Shares
December 11, 2000	Preferential Allotment	Cash	40	1,000	1,000	40
March 28, 2003	Preferential Allotment	Cash	1,505	1,000	1,000	1,545
January 04, 2008	Preferential Allotment	Cash	3	1,000	6,000	1,548
February 13, 2008	Preferential Allotment	Cash	4	1,000	6,000	1,552
February 20, 2008	Preferential Allotment	Cash	4	1,000	6,000	1,556
February 22, 2008	Preferential Allotment	Cash	4	1,000	6,000	1,560
February 23, 2008	Preferential Allotment	Cash	3	1,000	6,000	1,563
February 27, 2008	Preferential Allotment	Cash	3	1,000	6,000	1,566
February 28, 2008	Preferential Allotment	Cash	3	1,000	6,000	1,569
February 29, 2008	Preferential Allotment	Cash	2	1,000	6,000	1,571
March 03, 2008	Preferential Allotment	Cash	2	1,000	6,000	1,573
Pursuant to a resolution of our shareholders dated May 13, 2010, each equity share of our Company of face value ₹ 1,000 was sub divided into the face value of ₹ 10 each, and accordingly, 1,573 equity shares of ₹ 1,000 each held by Vinod Katti were split into 1,57,300 Equity Shares.						
February 22,	Transfer	Cash	250	10	200	1,57,550 <sup>(1)</sup>

2014						
------	--	--	--	--	--	--

<sup>(1)</sup> The entire holding of Vinod Katti i.e. 1,57,550 equity shares are offered as a part of Offer of Sale.

- **Details of the share capital held by Padmaja Katti**

Date of Allotment / Transfer	Nature of Transaction	Consideration	No. of Shares	Face Value (₹)	Issue Price / Transfer Price (₹)	Cumulative no. of Shares
December 11, 2000	Preferential Allotment	Cash	50	1,000	1,000	50
Pursuant to a resolution of our shareholders dated May 13, 2010, each equity share of our Company of face value ₹ 1,000 was sub divided into the face value of ₹ 10 each, and accordingly, 50 equity shares of ₹ 1,000 each held by Padmaja Katti were split into 5,000 Equity Shares.						
October 10, 2016	Transmission	Other Than Cash	5,000	10	-	10,000 <sup>(1)</sup>

<sup>(1)</sup> Out of the total holding of Padmaja Katti, 5,000 equity shares are offered as a part of Offer of Sale.

- **Details of the share capital held by Shridevi Angadi**

Date of Allotment / Transfer	Nature of Transaction	Consideration	No. of Shares	Face Value (₹)	Issue Price / Transfer Price (₹)	Cumulative no. of Shares
December 11, 2000	Preferential Allotment	Cash	60	1,000	1,000	60
November 15, 2007	Further Allotment	Cash	5	1,000	6,000	65 <sup>(1)</sup>
Pursuant to a resolution of our shareholders dated May 13, 2010, each equity share of our Company of face value ₹ 1,000 was sub divided into the face value of ₹ 10 each, and accordingly, 65 equity shares of ₹ 1,000 each held by Shridevi Angadi were split into 6,500 Equity Shares <sup>(1)</sup> .						

<sup>(1)</sup> The entire holding of Shridevi Angadi i.e. 6,500 equity shares are offered as a part of Offer of Sale.

- **Details of the share capital held by Pallavi Hawanale**

Date of Allotment / Transfer	Nature of Transaction	Consideration	No. of Shares	Face Value (₹)	Issue Price / Transfer Price (₹)	Cumulative no. of Shares
December 11, 2000	Preferential Allotment	Cash	60	1,000	1,000	60
November 15, 2007	Preferential Allotment	Cash	5	1,000	1,000	65 <sup>(1)</sup>
Pursuant to a resolution of our shareholders dated May 13, 2010, each equity share of our Company of face value ₹ 1,000 was sub divided into the face value of ₹ 10 each, and accordingly, 65 equity shares of ₹ 1,000 each held by Pallavi Hawanale were split into 6,500 Equity Shares <sup>(1)</sup> .						

<sup>(1)</sup> The entire holding of Pallavi Hawanale i.e. 6,500 equity shares are offered as a part of Offer of Sale.

- **Details of the share capital held by Rekha Katti**

Date of Allotment / Transfer	Nature of Transaction	Consideration	No. of Shares	Face Value (₹)	Issue Price / Transfer Price (₹)	Cumulative no. of Shares
December 11, 2000	Preferential Allotment	Cash	60	1,000	1,000	60 <sup>(1)</sup>
Pursuant to a resolution of our shareholders dated May 13, 2010, each equity share of our Company of face value ₹ 1,000 was sub divided into the face value of ₹ 10 each, and accordingly, 60 equity shares of ₹ 1,000 each held by Rekha Katti were split into 6,000 Equity Shares <sup>(1)</sup> .						

<sup>(1)</sup> The entire holding of Rekha Katti i.e. 6,000 equity shares are offered as a part of Offer of Sale.

- **Details of the share capital held by Sandeep Katti**

Date of Allotment / Transfer	Nature of Transaction	Consideration	No. of Shares	Face Value (₹)	Issue Price / Transfer Price (₹)	Cumulative no. of Shares
December 11, 2000	Preferential Allotment	Cash	60	1,000	1,000	60 <sup>(1)</sup>
Pursuant to a resolution of our shareholders dated May 13, 2010, each equity share of our Company of face value ₹ 1,000 was sub divided into the face value of ₹ 10 each, and accordingly, 60 equity shares of ₹ 1,000 each held by Sandeep Katti were split into 6,000 Equity Shares <sup>(1)</sup> .						

<sup>(1)</sup> The entire holding of Sandeep Katti i.e. 6,000 equity shares are offered as a part of Offer of Sale.

- **Details of the share capital held by Purnima Pangri**

Date of Allotment / Transfer	Nature of Transaction	Consideration	No. of Shares	Face Value (₹)	Issue Price / Transfer Price (₹)	Cumulative no. of Shares
December 11, 2000	Preferential Allotment	Cash	50	1,000	1,000	50 <sup>(1)</sup>
Pursuant to a resolution of our shareholders dated May 13, 2010, each equity share of our Company of face value ₹ 1,000 was sub divided into the face value of ₹ 10 each, and accordingly, 50 equity shares of ₹ 1,000 each held by Purnima Pangri were split into 5,000 Equity Shares <sup>(1)</sup> .						

<sup>(1)</sup> The entire holding of Purnima Pangri i.e. 5,000 equity shares are offered as a part of Offer of Sale.

- **Details of the share capital held by Sanjay Khemalapur**

Date of Allotment / Transfer	Nature of Transaction	Consideration	No. of Shares	Face Value (₹)	Issue Price / Transfer Price (₹)	Cumulative no. of Shares
December 11, 2000	Preferential Allotment	Cash	45	1,000	1,000	45
October 26, 2007	Further Allotment	Cash	4	1,000	6,000	49 <sup>(1)</sup>
Pursuant to a resolution of our shareholders dated May 13, 2010, each equity share of our Company of face value ₹ 1,000 was sub divided into the face value of ₹ 10 each, and accordingly, 49 equity shares of ₹ 1,000 each held by Sanjay Khemalapur were split into 4,900 Equity Shares <sup>(1)</sup> .						

<sup>(1)</sup> The entire holding of Sanjay Khemalapur i.e. 4,900 equity shares are offered as a part of Offer of Sale.

- **Details of the share capital held by Nirmala Lingadalli**

Date of Allotment / Transfer	Nature of Transaction	Consideration	No. of Shares	Face Value (₹)	Issue Price / Transfer Price (₹)	Cumulative no. of Shares
December 11, 2000	Preferential Allotment	Cash	35	1,000	1,000	35 <sup>(1)</sup>
Pursuant to a resolution of our shareholders dated May 13, 2010, each equity share of our Company of face value ₹ 1,000 was sub divided into the face value of ₹ 10 each, and accordingly, 35 equity shares of ₹ 1,000 each held by Nirmala Lingadalli were split into 3,500 Equity Shares <sup>(1)</sup> .						

<sup>(1)</sup> The entire holding of Nirmala Lingadalli i.e. 3,500 equity shares are offered as a part of Offer of Sale.

- **Details of the share capital held by Mahadevi Bellad**

Date of Allotment / Transfer	Nature of Transaction	Consideration	No. of Shares	Face Value (₹)	Issue Price / Transfer Price (₹)	Cumulative no. of Shares
December 11, 2000	Preferential Allotment	Cash	35	1,000	1,000	35 <sup>(1)</sup>
Pursuant to a resolution of our shareholders dated May 13, 2010, each equity share of our Company of face value ₹						

1,000 was sub divided into the face value of ₹ 10 each, and accordingly, 35 equity shares of ₹ 1,000 each held by Mahadevi Bellad were split into 3,500 Equity Shares<sup>(1)</sup>.

<sup>(1)</sup> The entire holding of Mahadevi Bellad i.e. 3,500 equity shares are offered as a part of Offer of Sale.

- **Details of the share capital held by Drakashayani Katti**

Date of Allotment / Transfer	Nature of Transaction	Consideration	No. of Shares	Face Value (₹)	Issue Price / Transfer Price (₹)	Cumulative no. of Shares
December 11, 2000	Preferential Allotment	Cash	35	1,000	1,000	35 <sup>(1)</sup>
Pursuant to a resolution of our shareholders dated May 13, 2010, each equity share of our Company of face value ₹ 1,000 was sub divided into the face value of ₹ 10 each, and accordingly, 35 equity shares of ₹ 1,000 each held by Drakashayani Katti were split into 3,500 Equity Shares <sup>(1)</sup> .						

<sup>(1)</sup> The entire holding of Drakashayani Katti i.e. 3,500 equity shares are offered as a part of Offer of Sale.

- **Details of the share capital held by Lalita Khemalapur**

Date of Allotment / Transfer	Nature of Transaction	Consideration	No. of Shares	Face Value (₹)	Issue Price / Transfer Price (₹)	Cumulative no. of Shares
December 11, 2000	Preferential Allotment	Cash	30	1,000	1,000	30 <sup>(1)</sup>
Pursuant to a resolution of our shareholders dated May 13, 2010, each equity share of our Company of face value ₹ 1,000 was sub divided into the face value of ₹ 10 each, and accordingly, 30 equity shares of ₹ 1,000 each held by Lalita Khemalapur were split into 3,000 Equity Shares <sup>(1)</sup> .						

<sup>(1)</sup> The entire holding of Lalita Khemalapur i.e. 3,000 equity shares are offered as a part of Offer of Sale.

- **Details of the share capital held by Yuvaraj Chunamuri**

Date of Allotment / Transfer	Nature of Transaction	Consideration	No. of Shares	Face Value (₹)	Issue Price / Transfer Price (₹)	Cumulative no. of Shares
December 11, 2000	Preferential Allotment	Cash	10	1,000	1,000	10
Pursuant to a resolution of our shareholders dated May 13, 2010, each equity share of our Company of face value ₹ 1,000 was sub divided into the face value of ₹ 10 each, and accordingly, 10 equity shares of ₹ 1,000 each held by Yuvaraj Chunamuri were split into 1,000 Equity Shares.						
August 28, 2016	Transmission	Other Than Cash	1,000	10	-	2,000 <sup>(1)</sup>

<sup>(1)</sup> Out of the total holding of Yuvaraj Chunamuri, 1,000 equity shares are offered as a part of Offer of Sale.

- **Details of the share capital held by Satish Ghuli**

Date of Allotment / Transfer	Nature of Transaction	Consideration	No. of Shares	Face Value (₹)	Issue Price / Transfer Price (₹)	Cumulative no. of Shares
December 11, 2000	Preferential Allotment	Cash	10	1,000	1,000	10
Pursuant to a resolution of our shareholders dated May 13, 2010, each equity share of our Company of face value ₹ 1,000 was sub divided into the face value of ₹ 10 each, and accordingly, 10 equity shares of ₹ 1,000 each held by Satish Ghuli were split into 1,000 Equity Shares.						
November 11, 2017	Transmission	Other Than Cash	1,000	10	-	2,000 <sup>(1)</sup>

<sup>(1)</sup> Out of the total holding of Satish Ghuli, 1,000 equity shares are offered as a part of Offer of Sale.

- **Details of the share capital held by Mohan Munnoli**

Date of Allotment / Transfer	Nature of Transaction	Consideration	No. of Shares	Face Value (₹)	Issue Price / Transfer Price (₹)	Cumulative no. of Shares
December 11, 2000	Preferential Allotment	Cash	20	1,000	1,000	20 <sup>(1)</sup>
Pursuant to a resolution of our shareholders dated May 13, 2010, each equity share of our Company of face value ₹ 1,000 was sub divided into the face value of ₹ 10 each, and accordingly, 20 equity shares of ₹ 1,000 each held by Mohan Munnoli were split into 2,000 Equity Shares <sup>(1)</sup> .						

<sup>(1)</sup> The entire holding of Mohan Munnoli i.e. 2,000 equity shares are offered as a part of Offer of Sale.

- **Details of the share capital held by Sudharshan Khemalapur**

Date of Allotment / Transfer	Nature of Transaction	Consideration	No. of Shares	Face Value (₹)	Issue Price / Transfer Price (₹)	Cumulative no. of Shares
December 11, 2000	Preferential Allotment	Cash	15	1,000	1,000	15 <sup>(1)</sup>
Pursuant to a resolution of our shareholders dated May 13, 2010, each equity share of our Company of face value ₹ 1,000 was sub divided into the face value of ₹ 10 each, and accordingly, 15 equity shares of ₹ 1,000 each held by Sudharshan Khemalapur were split into 1,500 Equity Shares <sup>(1)</sup> .						

<sup>(1)</sup> The entire holding of Sudharshan Khemalapur i.e. 1,500 equity shares are offered as a part of Offer of Sale.

- **Details of the share capital held by Pallavi Ghuli**

Date of Allotment / Transfer	Nature of Transaction	Consideration	No. of Shares	Face Value (₹)	Issue Price / Transfer Price (₹)	Cumulative no. of Shares
December 11, 2000	Preferential Allotment	Cash	10	1,000	1,000	10 <sup>(1)</sup>
Pursuant to a resolution of our shareholders dated May 13, 2010, each equity share of our Company of face value ₹ 1,000 was sub divided into the face value of ₹ 10 each, and accordingly, 10 equity shares of ₹ 1,000 each held by Pallavi Ghuli were split into 1,000 Equity Shares <sup>(1)</sup> .						

<sup>(1)</sup> The entire holding of Pallavi Ghuli i.e. 1,000 equity shares are offered as a part of Offer of Sale.

- **Details of the share capital held by Tejasvini Chunamuri**

Date of Allotment / Transfer	Nature of Transaction	Consideration	No. of Shares	Face Value (₹)	Issue Price / Transfer Price (₹)	Cumulative no. of Shares
December 11, 2000	Preferential Allotment	Cash	10	1,000	1,000	10 <sup>(1)</sup>
Pursuant to a resolution of our shareholders dated May 13, 2010, each equity share of our Company of face value ₹ 1,000 was sub divided into the face value of ₹ 10 each, and accordingly, 10 equity shares of ₹ 1,000 each held by Tejasvini Chunamuri were split into 1,000 Equity Shares <sup>(1)</sup> .						

<sup>(1)</sup> The entire holding of Tejasvini Chunamuri i.e. 1,000 equity shares are offered as a part of Offer of Sale.

- **Details of the share capital held by Prachi Ghuli**

Date of Allotment / Transfer	Nature of Transaction	Consideration	No. of Shares	Face Value (₹)	Issue Price / Transfer Price (₹)	Cumulative no. of Shares
December 11, 2000	Preferential Allotment	Cash	10	1,000	1,000	10 <sup>(1)</sup>
Pursuant to a resolution of our shareholders dated May 13, 2010, each equity share of our Company of face value ₹ 1,000 was sub divided into the face value of ₹ 10 each, and accordingly, 10 equity shares of ₹ 1,000 each held by Prachi Ghuli were split into 1,000 Equity Shares <sup>(1)</sup> .						

<sup>(1)</sup> The entire holding of Prachi Ghuli i.e. 1,000 equity shares are offered as a part of Offer of Sale.

- **Details of the share capital held by Suhas Ghuli**

Date of Allotment / Transfer	Nature of Transaction	Consideration	No. of Shares	Face Value (₹)	Issue Price / Transfer Price (₹)	Cumulative no. of Shares
December 11, 2000	Preferential Allotment	Cash	10	1,000	1,000	10
Pursuant to a resolution of our shareholders dated May 13, 2010, each equity share of our Company of face value ₹ 1,000 was sub divided into the face value of ₹ 10 each, and accordingly, 10 equity shares of ₹ 1,000 each held by Suhas Ghuli were split into 1,000 Equity Shares.						
September 30, 2018	Transfer (Gift)	Other Than Cash	1,000	10	-	2,000 <sup>(1)</sup>

<sup>(1)</sup> Out of the total holding of Suhas Ghuli, 1,000 equity shares are offered as a part of Offer of Sale.

- **Details of the share capital held by Channavva Chunamuri**

Date of Allotment / Transfer	Nature of Transaction	Consideration	No. of Shares	Face Value (₹)	Issue Price / Transfer Price (₹)	Cumulative no. of Shares
December 11, 2000	Preferential Allotment	Cash	10	1,000	1,000	10 <sup>(1)</sup>
Pursuant to a resolution of our shareholders dated May 13, 2010, each equity share of our Company of face value ₹ 1,000 was sub divided into the face value of ₹ 10 each, and accordingly, 10 equity shares of ₹ 1,000 each held by Channavva Chunamuri were split into 1,000 Equity Shares <sup>(1)</sup> .						

<sup>(1)</sup> The entire holding of Channavva Chunamuri i.e. 1,000 equity shares are offered as a part of Offer of Sale.

- **Details of the share capital held by Shanmukappa Chunamuri**

Date of Allotment / Transfer	Nature of Transaction	Consideration	No. of Shares	Face Value (₹)	Issue Price / Transfer Price (₹)	Cumulative no. of Shares
December 11, 2000	Preferential Allotment	Cash	10	1,000	1,000	10 <sup>(1)</sup>
Pursuant to a resolution of our shareholders dated May 13, 2010, each equity share of our Company of face value ₹ 1,000 was sub divided into the face value of ₹ 10 each, and accordingly, 10 equity shares of ₹ 1,000 each held by Shanmukappa Chunamuri were split into 1,000 Equity Shares <sup>(1)</sup> .						

<sup>(1)</sup> The entire holding of Shanmukappa Chunamuri i.e. 1,000 equity shares are offered as a part of Offer of Sale.

- **Details of the share capital held by Kalavati Savadakar**

Date of Allotment / Transfer	Nature of Transaction	Consideration	No. of Shares	Face Value (₹)	Issue Price / Transfer Price (₹)	Cumulative no. of Shares
December 11, 2000	Preferential Allotment	Cash	10	1,000	1,000	10 <sup>(1)</sup>
Pursuant to a resolution of our shareholders dated May 13, 2010, each equity share of our Company of face value ₹ 1,000 was sub divided into the face value of ₹ 10 each, and accordingly, 10 equity shares of ₹ 1,000 each held by Kalavati Savadakar were split into 1,000 Equity Shares <sup>(1)</sup> .						

<sup>(1)</sup> The entire holding of Kalavati Savadakar i.e. 1,000 equity shares are offered as a part of Offer of Sale.

- **Details of the share capital held by Shailaja Uchale**

Date of Allotment / Transfer	Nature of Transaction	Consideration	No. of Shares	Face Value (₹)	Issue Price / Transfer Price (₹)	Cumulative no. of Shares
December 11, 2000	Preferential Allotment	Cash	10	1,000	1,000	10 <sup>(1)</sup>



Pursuant to a resolution of our shareholders dated May 13, 2010, each equity share of our Company of face value ₹ 1,000 was sub divided into the face value of ₹ 10 each, and accordingly, 10 equity shares of ₹ 1,000 each held by Shailaja Uchale were split into 1,000 Equity Shares<sup>(1)</sup>.

<sup>(1)</sup> The entire holding of Shailaja Uchale i.e. 1,000 equity shares are offered as a part of Offer of Sale.

**The Equity Shares constituting the Offer for Sale are in compliance with the requirements of Regulation 26(6) of the SEBI ICDR Regulations.**

**10. Sales or purchases of Equity Shares or other specified securities of our Company by our Promoters, the other members of our Promoter Group or our Directors or their immediate relatives during the six months immediately preceding the date of the Draft Red Herring Prospectus.**

Our Promoters, the other members of our Promoter Group or our Directors or their immediate relatives have not sold or purchased any Equity Shares or other specified securities of our Company during the six months immediately preceding the date of the Draft Red Herring Prospectus, except as follows:

Name of the member of Promoter Group or Directors or their immediate relatives	No. of Equity Shares purchased	No. of Equity Shares sold/transferred	Date of transaction	Transaction price per Equity Share (in ₹)
Umesh Katti	10,000 <sup>(1)</sup>		September 25, 2017	150.00
	6,100 <sup>(2)</sup>		October 25, 2017	407.00
Nikhil Katti <sup>#</sup>	20,100 <sup>(1)</sup>		September 25, 2017	150.00
	16,650 <sup>(2)</sup>		October 25, 2017	407.00

<sup>(1)</sup> These shares were acquired by Umesh Katti and Nikhil Katti through Exit Offer – 1. For details please refer Notes to Capital Structure – Capital Structure on page no. 70 of this Red Herring Prospectus.

<sup>(2)</sup> These shares were acquired by Umesh Katti and Nikhil Katti through Exit Offer – 2. For details please refer Notes to Capital Structure – Capital Structure on page no. 70 of this Red Herring Prospectus.

**11. Demat of Shares**

The Company has started informing the shareholders the need for converting their shares into dematerialisation form and is also actively assisting in the same. As on date of this Red Herring Prospectus, 100% of the shares held by Promoter & Promoter Group i.e. 1,87,35,600 Equity Shares are in Demat mode and hence we are in compliance with Regulation 31 (2) of the SEBI Listing Regulations.

Further, as per the Clause 6 (d) of SEBI Circular no. CIR/CFD/CMD/13/2015 dated November 30, 2015, 50% of the total public shareholding of the Post-Offer paid-up share capital of the Company is required to be in dematerialised form which amounts to 1,26,13,225 Equity Shares. As on date of this Red Herring Prospectus, 42,38,300 Equity Shares forming part of public shareholding are in Demat form. Including the proposed Offer, consisting of 30,00,000 Equity Shares Fresh Issue and 64,06,050 Equity Shares of offered for sale by Promoter & Promoter Group (out of 70,00,000 Equity Shares proposed for OFS), which will be offered to the public in demat form only as per the Section 29 (1) of the Companies Act, 2013, our Company has will be in Compliance with the above mentioned circular having 54.09% of public shareholding in Demat form.

**12. Details of Lock-in**

**a. Details of Promoter’s Contribution locked in for three years**

Pursuant to Regulations 32 and 36 of the SEBI ICDR Regulations, an aggregate of 20% of the fully diluted post-Offer capital of our Company held by our Promoters shall be considered as minimum promoters’ contribution and locked-in for a period of three years from the date of Allotment (“**Promoters’ Contribution**”).

As on the date of this Red Herring Prospectus, our Promoters collectively hold 1,17,34,750 Equity Shares. After successful completion of the IPO, our Promoters will collectively hold 1,13,34,750 Equity Shares and all these Equity Shares, constituting 30.18% of our Company’s post – Offer paid-up equity share capital is eligible for Promoters’ Contribution.

The details of the Equity Shares held by our Promoters, which shall be locked-in for a period of three years from the date of allotment, are set out in the following table:

Name of Promoter	No. of Shares locked in <sup>(1)</sup>	As a % of Post Offer Share Capital
Umesh Katti	9,50,000	2.53%
Ramesh Katti	8,91,000	2.37%
Sheela Katti	7,65,000	2.04%
Jayashree Katti	8,44,000	2.25%
Nikhil Katti	23,42,000	6.24%
Lava Katti	7,38,000	1.97%
Kush Katti	7,68,000	2.04%
Sneha Nithin Dev	3,02,000	0.80%
<b>Total</b>	<b>76,00,000</b>	<b>20.24%</b>

<sup>(1)</sup> For details regarding allotment of the above Equity Shares, please refer Note no. 2 under “Notes to Capital Structure” on page no. 70 of this Red Herring Prospectus.

Our Promoters have confirmed to our Company and the BRLM that the acquisition of equity shares which have been allotted for cash have been financed from the personal funds, internal accruals and no loans or financial assistance from any bank or financial institution has been availed for such purpose.

The Promoters’ Contribution has been brought in to the extent of not less than the specified minimum lot, as required under the SEBI ICDR Regulations.

The Equity Shares that are being locked-in for computation of Promoters’ Contribution are not, and will not be, ineligible under Regulation 33 of the SEBI ICDR Regulations. In particular, these Equity Shares do not, and shall not, consist of:

- i. Equity Shares acquired during the three years preceding the date of this Red Herring Prospectus (a) for consideration other than cash and revaluation of assets or capitalisation of intangible assets, or (b) bonus shares issued out of revaluations reserves or unrealised profits or against equity shares which are otherwise ineligible for computation of promoters’ contribution;
- ii. Equity Shares acquired during the one year preceding the date of this Red Herring Prospectus, at a price lower than the price at which the Equity Shares are being offered to the public in the Offer;
- iii. Equity Shares issued to the Promoters in the last one year preceding the date of this Red Herring Prospectus upon conversion of a partnership firm; and
- iv. Equity Shares held by the Promoters that are subject to any pledge or any other form of encumbrance.

**b. Details of share capital locked-in for one year**

Except for the Promoter’s Contribution which shall be locked-in as above, the entire pre-Offer capital of our Company shall be locked in for a period of one year from the date of Allotment, except for OFS shares.

Our Company in consultation with the Registrar to the Offer have outlined the following steps to ensure that the entire pre-Offer shareholding of our Company, except for OFS shares, will be locked-in as per Regulation 37 of the SEBI ICDR Regulations:

- Our Company has started the process of converting as many shares as possible to Dematerialised form by conveying the same to its farmers and also assisting them in opening Demat accounts.
- For shareholders, who fail or are unable to convert their shares to demat form, our Company will send to each such shareholder, a Sticker with the label of ‘Not Transferable’ which they will be instructed to put on their share certificates for a period of one year.
- The Registrar to the Offer will have a comprehensive list of shareholders whose shares are still in the physical form along with the Distinctive Numbers of such shares in its internal software. The BRLM and our Company will instruct the Registrar to the Offer to ‘Flag’ / ‘Flap’ such distinctive numbers and that no transfer in shares bearing these distinctive numbers will be allowed for the period upto which the lock-in is applicable.

- Further, as per MCA notification dated September 10, 2018, shares of unlisted public companies held by shareholders cannot be transferred unless the same are in demat form after October 02, 2018. Further, and as per Regulation 40 of SEBI Listing Regulations, as amended, and subsequent press release, shares of listed companies cannot be transferred in physical form after April 01, 2019.

Pursuant to Regulation 39 of the SEBI ICDR Regulations, the Equity Shares held by our Promoters which are locked-in for a period of one year from the date of Allotment may be pledged only with scheduled commercial banks or public financial institutions as collateral security for loans granted by such banks or public financial institutions, provided that such pledge of the Equity Shares is one of the terms of the sanction of such loans.

In terms of Regulation 40 of the SEBI ICDR Regulations, Equity Shares held by the Promoter may be transferred to and among the Promoters and or members of the Promoter Group or a new promoter or persons in control of our Company, subject to continuation of lock-in in the hands of the transferee for the remaining period and compliance with provisions of the Takeover Code. The Equity Shares held by persons other than the Promoter prior to the Offer, may be transferred to any other person holding Equity Shares which are locked in along with the Equity Shares proposed to be transferred, subject to the continuation of the lock-in in the hands of the transferee and compliance with the provisions of the Takeover Regulations.

### 13. Shareholding Pattern

The following is the shareholding pattern of the Company as on the date of this Red Herring Prospectus

Category (I)	Category of Share-holder (II)	No. of Share-holder (III)	No. of fully paid-up equity shares held (IV)	No. of Partly paid-up equity shares held (V)	No. of shares Underlying Depository Receipts (VI)	Total Nos. Shares held (VII) = (IV) + (V) + (VI)	Share holding as a % of total No. of Shares (calculated As per SCRR, 1957)(VIII)As a % of (A+B+C2)	Number of Voting Rights held in each Class of securities (IX)			No of Underlying Outstanding Convertible securities (incl. Warrants) (X)	Share Holding as a % assuming Full convertible securities (as a % of Diluted Share Capital)(XI)=(VII)+(X) As a % of (A+B+C2)	Number of Locked In shares (XII)		No. of shares Pledged Or Otherwise encumbered (XIII)		No. of Equity shares held in De-mat form (XIV)	
								No of voting Right					Total As a % of (A+B+C)	No (a)	As a % of total shares held (b)	No (a)		As a % of total shares held (b)
								Class-Equity	Class	Total								
A	Promoter & Promoter Group	39	1,87,35,600	-	-	1,87,35,600	54.22%	1,87,35,600	-	1,87,35,600	54.22%	-	-	-	-	-	1,87,35,600	
B	Public	9,882	1,58,20,400	-	-	1,58,20,400	45.78%	1,58,20,400	-	1,58,20,400	45.78%	-	-	-	-	-	42,38,300	
C	Non Promoter Non Public	-	-	-	-	-	-	-	-	-	-	-	-	-	-	-	-	
C 1	Shares Underlying DRs	-	-	-	-	-	-	-	-	-	-	-	-	-	-	-	-	
C 2	Shares held by Employee Trusts	-	-	-	-	-	-	-	-	-	-	-	-	-	-	-	-	
	<b>Total</b>	<b>9,921</b>	<b>3,45,56,000</b>	<b>-</b>	<b>-</b>	<b>3,45,56,000</b>	<b>100.00%</b>	<b>3,45,56,000</b>	<b>-</b>	<b>3,45,56,000</b>	<b>100.00%</b>	<b>-</b>	<b>-</b>	<b>-</b>	<b>-</b>	<b>-</b>	<b>2,29,73,900</b>	

Our Company will file the shareholding pattern, in the form prescribed under Regulation 31 of the Listing Regulations, one day prior to the listing of the Equity Shares. The shareholding pattern will be provided to the Stock Exchanges for uploading on the website of Stock Exchanges before the commencement of trading of the Equity Shares.

#### 14. Shareholding of our Directors and Key Management Personnel in our Company

Other than as set forth below, none of the Directors and Key Managerial Personnel holds Equity Shares as on the date of this Red Herring Prospectus:

Name	No. of Equity Shares	% of Pre-Offer Equity Share Capital
<i>Directors</i>		
Umesh Katti	14,18,575	4.11%
Nikhil Katti	36,92,875	10.69%
Lava Katti	12,00,275	3.47%
Kush Katti	12,45,075	3.60%
Basavaraj Hagaragi	54,900	0.16%
<i>Key Managerial Personnel</i>		
Vinosali Mullani	51,000	0.15%
Chanamallaya Hiremath	50	Negligible
<b>TOTAL</b>	<b>76,62,750</b>	<b>22.17%</b>

15. Public shareholders holding more than 1% of the pre-Offer paid-up capital of our Company as on the date of this Red Herring Prospectus are as below:

Sr. No.	Name of the Shareholder	No. of Shares	% of Pre-Offer Share Capital
1.	Riyaz Bargeer	7,89,000	2.28%
2.	Basavaraj Mahashetti	5,40,000	1.56%
3.	Appasaheb Shiragur	4,55,500	1.32%
4.	Siddappa Hagaragi	4,03,200	1.17%
5.	Ramesh Munnoli	3,69,800	1.07%

16. As on the date of this Red Herring Prospectus, our Company has 9,921 shareholders of Equity Shares.

#### 17. Top 10 shareholders

a) Our top 10 equity shareholders and the number of Equity Shares held by them, as on the date of this Red Herring Prospectus are as follows:

Sr. No.	Name of Shareholder	No. of Equity Shares Held	% of Pre-Offer Share Capital
1	Nikhil Katti	36,92,875	10.69%
2	Umesh Katti	14,18,575	4.11%
3	Ramesh Katti	13,28,950	3.85%
4	Jayashree Katti	12,58,800	3.64%
5	Kush Katti	12,45,075	3.60%
6	Lava Katti	12,00,275	3.47%
7	Sheela Katti	11,41,000	3.30%
8	Ashok Utture	10,29,300	2.98%
9	Riyaz Bargeer	7,89,100	2.28%
10	Kashinath Utture	6,81,000	1.97%
<b>TOTAL</b>		<b>1,37,84,950</b>	<b>39.89%</b>

b) Our top 10 equity shareholders and the number of Equity Shares held by them, as on the 10 days prior to filing of the Draft Red Herring Prospectus are as follows:

Sr. No.	Name of Shareholder	No. of Equity Shares Held	% of Pre-Offer Share Capital
1	Nikhil Katti	36,92,875	10.69%
2	Umesh Katti	14,18,575	4.11%
3	Ramesh Katti	13,28,950	3.85%
4	Jayashree Katti	12,58,800	3.64%

5	Kush Katti	12,45,075	3.60%
6	Lava Katti	12,00,275	3.47%
7	Sheela Katti	11,41,000	3.30%
8	Ashok Utture	10,29,300	2.98%
9	Riyaz Bargeer	7,89,100	2.28%
10	Kashinath Utture	6,81,000	1.97%
<b>TOTAL</b>		<b>1,37,84,950</b>	<b>39.89%</b>

c) Our top 10 Equity Shareholders two years prior to filing of this Red Herring Prospectus are as follows:

Sr. No.	Name of Shareholder	No. of Equity Shares Held	% of Pre-Offer Share Capital
1	Nikhil Katti	36,56,125	10.58%
2	Umesh Katti	14,02,475	4.06%
3	Ramesh Katti	13,28,950	3.85%
4	Jayashree Katti	12,58,800	3.64%
5	Kush Katti	12,45,075	3.60%
6	Lava Katti	12,00,275	3.47%
7	Sheela Katti	11,41,000	3.30%
8	Ashok Utture	10,29,300	2.98%
9	Riyaz Bargeer	7,89,100	2.28%
10	Kashinath Utture	6,81,000	1.97%
<b>TOTAL</b>		<b>1,37,32,100</b>	<b>39.73%</b>

18. Our Company does not have an employee stock option plan.
19. Our Company, our Directors and the BRLM have not entered into any buy-back, standby and/or any other similar arrangements for the purchase of Equity Shares being offered through this Offer.
20. Neither the BRLM nor its associates (as defined under the Securities and Exchange Board of India (Merchant Bankers) Regulations, 1992) hold any Equity Shares as of the date of filing of this Red Herring Prospectus. The BRLM and its affiliates may engage in transactions with and perform services for our Company in the ordinary course of business or may in the future engage in commercial banking and investment banking transactions with our Company, for which they may in the future receive customary compensation.
21. No person connected with the Offer, including, but not limited to, the BRLM, the members of the Syndicate, our Company, the Directors, the Promoters or the members of our Promoter Group, shall offer in any manner whatsoever any incentive, whether direct or indirect, in cash, in kind or in services or otherwise to any Bidder for making a Bid.
22. Our Company does not have any revaluation reserves and hence has not issued any Equity Shares out of any revaluation reserve or unrealised profits.
23. The Equity Shares are fully paid-up and there are no partly paid-up Equity Shares as of the date of filing this Red Herring Prospectus.
24. Except for the Issue, our Company presently does not intend or propose to alter its capital structure for a period of six months from the Bid/Offer Opening Date, by way of split or consolidation of the denomination of Equity Shares or further issue of Equity Shares (including issue of securities convertible into or exchangeable, directly or indirectly for Equity Shares) whether on a preferential basis or by way of issue of bonus shares or on a rights basis or by way of further public issue of Equity Shares or qualified institutions placements or otherwise.
25. Except for this Fresh Issue, there will be no further issue of Equity Shares whether by way of issue of bonus shares, preferential allotment, rights issue or in any other manner during the period commencing from filing of the Draft Red Herring Prospectus with SEBI until the Equity Shares have been listed on the Stock Exchanges.
26. During the period of six months immediately preceding the date of filing of the Draft Red Herring Prospectus, no financing arrangements existed whereby our Promoter, our Promoter Group, our Directors or their relatives may have financed the purchase of Equity Shares by any other person.



27. There are no outstanding convertible securities or any other right which would entitle any person any option to receive Equity Shares, as on the date of this Red Herring Prospectus.
28. This Offer is being made under Rule 19(2)(b)(i) of the SCRR read and in accordance with Regulation 26(1) of the SEBI ICDR Regulations. The Offer is being made through the Book Building Process, wherein not more than 10% of the Offer shall be allocated to QIBs on a proportionate basis. 5% of the QIB Portion shall be available for allocation on a proportionate basis to Mutual Funds only. The remainder of the QIB Portion shall be available for allocation on a proportionate basis to all QIBs, including Mutual Funds, subject to valid Bids being received from them at or above the Offer Price. Further, not less than 40% of the Offer shall be available for allocation on a proportionate basis to Non- Institutional Bidders and not less than 50% of the Offer shall be available for allocation to Retail Individual Bidders in accordance with the SEBI ICDR Regulations, subject to valid Bids being received from them at or above the Offer Price.
29. Subject to valid Bids being received at or above the Offer Price, under-subscription, if any, in any category, except in the QIB Portion, would be allowed to be met with spill over from any other category or a combination of categories at the discretion of our Company and the Selling Shareholders in consultation with the BRLM and the Designated Stock Exchange. Such inter-se spill-over, if any, would be effected in accordance with applicable laws, rules, regulations and guidelines. Under-subscription, if any, in the QIB Category will not be allowed to be met with spill-over from any category or combination thereof.
30. The Equity Shares issued pursuant to this Offer shall be fully paid-up at the time of Allotment, failing which, no Allotment shall be made.
31. There shall be only one denomination of the Equity Shares, unless otherwise permitted by law.
32. Our Company shall ensure that transactions in the Equity Shares by the Promoter and the Promoter Group during the period between the date of registering the Red Herring Prospectus with the RoC and the date of closure of the Offer shall be reported to the Stock Exchanges within 24 hours of the transactions.
33. Our Company has not made any public issue (including any rights issue to the public) since its incorporation in terms of SEBI ICDR Regulations.
34. Any oversubscription to the extent of 10% of the Offer can be retained for the purposes of rounding off to the nearer multiple of minimum allotment lot. Consequently, the actual allotment may go up by a maximum of 10% of the Fresh Issue, as a result of which, the post-issue paid up capital after the Offer would also increase by the excess amount of allotment so made. In such an event, the Equity Shares held by the Promoters and subject to lock- in shall be suitably increased; so as to ensure that 20% of the post Issue paid-up capital is locked in.
35. Except for the sale of part of Equity Shares in the Offer for Sale by our Promoters and our Promoter Group and the public Selling Shareholders, they will not participate in the Offer.
36. The Company and the BRLM confirm that the post-Offer paid up share capital of the Company shall not exceed the Authorised Capital of the Company.

## SECTION IV – PARTICULARS OF THE OFFER

### OBJECTS OF THE OFFER

The Offer comprises of a Fresh Issue by our Company and an Offer for Sale by the Selling Shareholders.

#### *The Offer for Sale*

The Selling Shareholders propose to sell an aggregate of up to 70,00,000 Equity Shares held by them, aggregating up to ₹ [●] lakhs. Our Company will not receive any proceeds of the Offer for Sale by the Selling Shareholders.

#### **Fresh Issue Proceeds & Net Fresh Issue Proceeds**

##### *Fresh Issue Proceeds*

The details of the proceeds of the Fresh Issue are set forth in the table below:

(₹ in lakhs)

Sr. No.	Particulars	Amount
1	Gross Proceeds of the Fresh Issue	[●]
2	Company's share of Offer related Expenses <sup>(1)</sup>	[●]
	<b>Net Proceeds of the Fresh Issue</b>	<b>[●]</b>

<sup>(1)</sup> Except for the Regulatory related expenses, which will be borne by our Company, all other expenses relating to the Offer as mentioned above will be borne by our Company and the Selling Shareholders in proportion to the Equity Shares contributed to the Offer. The Offer expenses are estimated expenses and subject to change.

##### *Net Fresh Issue*

The Objects of the Net Fresh Issue is to raise funds for:

- (a) Funding Working Capital Requirement
- (b) General corporate purpose

Further, our Company expects that the listing of the Equity Shares will enhance our visibility and our brand image among our existing and potential customers.

The Main Objects clause as set out in the Memorandum of Association enables our Company to undertake its existing activities and the activities for which funds are being raised by the Company through the Present Offer. Further, we confirm that the activities that we have been conducting until now are in accordance with the objects clause of our Memorandum of Association.

#### **Proposed Schedule of Implementation and Deployment of the Net Proceeds**

The Net Proceeds of the Fresh Issue ("Net Proceeds") are currently expected to be deployed in accordance with the schedule as stated below:

(₹ in lakhs)

Sr. No.	Object	Amount to be funded from Net Proceeds	Amount to be deployed from Net Proceeds in Fiscal 2020
1.	Funding Working Capital Requirement	1,570.00	1,570.00
2.	General Corporate Purpose	[●]	[●]
	<b>Total</b>	<b>[●]</b>	<b>[●]</b>

#### **Requirement of Funds and Means of Finance**

The fund requirements mentioned above are based on the internal management estimates of our Company and have not been verified by the BRLM or appraised by any bank, financial institution or any other external agency. They are based on current circumstances of our business and our Company may have to revise its estimates from time to time on account of various factors beyond its control, such as market conditions, competitive environment, costs of commodities and interest or exchange rate fluctuations. Consequently, the fund requirements of our Company are subject to revisions in the future at the discretion of the management. In the event of any shortfall of funds for the

activities proposed to be financed out of the Net Proceeds as stated above, our Company may re-allocate the Net Proceeds to the activities where such shortfall has arisen, subject to compliance with applicable laws. Further, in case of a shortfall in the Net Proceeds or cost overruns, our management may explore a range of options including utilising our internal accruals or seeking debt financing.

The entire fund requirements are to be financed from the Net Fresh Issue Proceeds, and there is no requirement to make firm arrangements of finance under Regulation 4(2)(g) of the SEBI Regulations through verifiable means towards at least 75% of the stated means of finance, excluding the amounts to be raised through the Offer.

For further details on the risks involved in our proposed fund utilization as well as executing our business strategies, please refer the “*Risk Factors - Our management will have broad discretion in how we apply the Net Proceeds, including interim use of the Net Proceeds, and there is no assurance that the objects of the Issue will be achieved within the time frame expected or at all, or that the deployment of the Net Proceeds in the manner intended by us will result in any increase in the value of your investment. Further, the funding plan has not been appraised by any bank or financial institution*”. on page no. 35 of this Red Herring Prospectus.

## DETAILS OF THE FUND REQUIREMENTS

### 1) Funding Working Capital Requirement

Our business is working capital intensive and we fund the majority of our working capital requirements in the ordinary course of our business from financing from various banks, financial institutions and internal accruals. As at March 31, 2019, our sanctioned working capital facilities comprised ₹ 26,500 lakhs from various banks & other financial institutions and out of which an amount of ₹ 25,385.68 lakhs was outstanding. For further information, please refer “*Financial Indebtedness*” on page no. 273 of this Red Herring Prospectus.

### Basis of estimation of working capital requirement and estimated working capital requirement

Our Company’s existing working capital requirement on the basis of our Restated Financial Statements for the Fiscal 2018 & 2019 are as set out in the table below:

(₹ in lakhs)

Particulars	Fiscal 2018	Fiscal 2019
<b>Current Assets</b>		
Inventories	26,157.20	32,434.62
Trade Receivables	3,388.06	3,835.87
Cash and Bank Balances	745.72	184.35
Current Financial Assets	4.61	4.47
Other Current Assets	4,667.56	7,606.26
<b>Total (A)</b>	<b>34,963.15</b>	<b>44,065.57</b>
<b>Current Liabilities</b>		
Trade Payables	2,686.39	11,271.89
Current Financial Liabilities	2,417.46	3,716.34
Other Current Liabilities	2,664.44	2,931.57
<b>Total (B)</b>	<b>7,768.29</b>	<b>17,919.80</b>
<b>Net working capital requirement (A - B)</b>	<b>27,194.86</b>	<b>26,145.77</b>

Our working capital requirement as on March 31, 2019 is funded from Working Capital Facilities from Banks & Others Financial Institutions to the tune of ₹ 25,385.68 lakhs and balance from internal accruals / owned funds to the tune of ₹ 760.09 lakhs.

The details of our Company’s expected working capital requirements for the Fiscal 2020 and funding of the same are as set out in the table below:

(₹ in lakhs)

Particulars	Fiscal 2020 (E)
<b>Current Assets</b>	
Inventories	30,760.00
Trade Receivables	5,130.00

Particulars	Fiscal 2020 (E)
Cash and Bank Balances	1,020.00
Current Financial Assets	10.00
Other Current Assets	6,130.00
<b>Total (A)</b>	<b>43,050.00</b>
<b>Current Liabilities</b>	
Trade Payables	6,050.00
Current Financial Liabilities	3,910.00
Other Current Liabilities	4,270.00
<b>Total (B)</b>	<b>14,230.00</b>
<b>Net working capital requirement (A - B)</b>	<b>28,820.00</b>
<b>Funding Pattern</b>	
Working Capital Facilities from Banks & Others Financial Institutions <sup>(1)</sup>	24,327.00
Internal Accruals / Owned Funds <sup>(2)</sup>	2,923.00
Amount proposed to be utilised from Net Proceeds	<b>1,570.00</b>

<sup>(1)</sup> Our sanctioned working capital facilities as on date of this Red Herring Prospectus comprised ₹ 24,327 lakhs from various banks and other financial institutions.

<sup>(2)</sup> The Statutory Auditors of the Company, M/s. Gojanur & Co., Chartered Accountants, vide their certificate dated July 08, 2019 have confirmed that the Company's 'Internal Accruals' as on March 31, 2019 aggregates to ₹ 21,941.73 lakhs.

Our Statutory Auditor has, pursuant to a certificate dated July 08, 2019, certified the working capital requirements of our Company for the Fiscal 2020.

#### Assumptions for Working Capital requirements

##### *Holding levels*

Provided below are details of the holding levels (days, rounded-off) considered.

Particulars	As on March 31, 2018 (Actual)	As on March 31, 2019 (Actual)	Average Holding Period	For the year ended March 31, 2020 (Assumed)
<b>Current Assets</b>				
Inventories	312	350	330	300
Trade Receivables	55	45	50	50
Cash and Bank Balances	14	6	10	10
Current Financial Assets	0.14	0.05	0.10	0.10
Other Current Assets	48	73	60	60
<b>Current Liabilities</b>				
Trade Payables	50	120	85	85
Current Financial Liabilities	55	53	54	55
Other Current Liabilities	75	48	61	60

##### *Justification for holding period levels*

Particulars	Details
<b>Current Assets</b>	
Inventories	Inventories days are computed from the historic Restated Financial Statements. The sugar industry is characterised by high inventory due to its seasonal nature. Further, with lower sugar wholesale price, substantial inventory was stocked. Our Company estimates, Inventory level to be at 300 days for the financial year 2019-20.
Trade Receivables	Trade Receivables days are computed from the historic Restated Financial

	Statements and are adjusted for future estimates. Our Company has estimated the holding level for Trade Receivable as 50 days of revenue from operations for the Financial Year 2019-20, considering continuation of current credit period due to volatile turnover growth.
Cash and Bank Balances	Cash and Bank Balances are computed from the historic Restated Financial Statements. Our Company has estimated the holding level of 10 days of revenue from operations for the Financial Year 2019-20.
Current Financial Assets	Current Financial Assets are computed from the historic Restated Financial Statements. Our Company has estimated the holding level for Current Financial Assets as less than 1 (one) day of revenue from operations for the Financial Year 2019-20 will be sufficient in future.
Other Current Assets	Other Current Assets are computed from the historic Restated Financial Statements. Our Company has estimated the holding level for other current assets as 60 days of revenue from operations for the Financial Year 2019-20.
<b>Current Liabilities</b>	
Trade Payables	Trade Payables are computed from the historic Restated Financial Statements. The average trade payables for the financial year 2019 and 2018 are 85 days and our Company estimates the same to continue at similar levels of the cost of goods sold for the Financial Year 2019-20.
Current Financial Liabilities	Current Financial Liabilities are computed from the historic Restated Financial Statements. Our Company has estimated the holding level of Current Financial Liabilities as 55 days of cost of goods sold for the Financial Year 2019-20.
Other Current Liabilities	Other Current Liabilities are computed from the historic Restated Financial Statements. Our Company has estimated the holding level of other current liabilities as 60 days of cost of goods sold for the Financial Year 2019-20. Our Company intends to make timely payments for various interest payments, current maturities and statutory payments.

## 2) General Corporate Purpose

Our Company proposes to deploy the balance Net Proceeds, aggregating to ₹ [●] Lakhs, towards general corporate purposes, subject to such utilisation not exceeding 25% of the gross proceeds of the Fresh Issue, in compliance with the Regulation 4(4) of the SEBI ICDR Regulations.

Our management will have flexibility to deploy ₹ [●], aggregating to [●]% of the Net Proceeds of the Fresh Issue towards general corporate purposes, including but not restricted to strategic initiatives, partnerships, joint ventures and acquisitions, meeting exigencies which our Company may face in the ordinary course of business, to renovate and refurbish certain of our existing Company owned/leased and operated facilities or premises, towards brand promotion activities or any other purposes as may be approved by our Board, subject to compliance with the necessary provisions of the Companies Act.

Our management, in accordance with the policies of the Board, will have flexibility in utilizing any amounts for general corporate purposes under the overall guidance and policies of our Board. The quantum of utilization of funds towards any of the purposes will be determined by the Board, based on the amount actually available under this head and the business requirements of our Company, from time to time.

We confirm that any issue related expenses shall not be considered as a part of General Corporate Purpose. Further, we confirm that the amount for general corporate purposes, as mentioned in this Red Herring Prospectus, shall not exceed 25% of the amount raised by our Company through the Fresh Issue of Equity Shares.

### OFFER RELATED EXPENSES

The total estimated Offer Expenses are ₹ [●], which is [●]% of the total Offer Size. The details of the Offer Expenses are tabulated below:

Sr. No.	Particulars	Amount (₹ in lakhs)	% of Total Expenses	% of Total Issue size
1	Offer Management fees including fees and payment to other intermediaries such as Legal Advisors, Registrars and other out of pocket expenses.	[●]	[●]%	[●]%

2	Brokerage and selling commission including fees payable to the Sponsor Bank for Bids made by RIIs using the UPI Mechanism <sup>(1)(2)(3)(4)(5)</sup>	[●]	[●]%	[●]%
3	Printing & Stationery, Distribution, Postage, etc.	[●]	[●]%	[●]%
4	Advertisement and Marketing Expenses	[●]	[●]%	[●]%
5	Stock Exchange Fees, Regulatory and other Expenses	[●]	[●]%	[●]%
<b>Total</b>		[●]	[●]%	[●]%

- 1) *Selling commission payable to the SCSBs on the portion for Retail Individual Bidders and Non-Institutional Bidders, which are directly procured by the SCSBs would be as follows:*

<i>Portion for Retail Individual Bidders<sup>#</sup></i>	<i>0.35% of the Amount Allotted (plus GST)</i>
<i>Portion for Non-Institutional Bidders<sup>#</sup></i>	<i>0.20% of the Amount Allotted (plus GST)</i>

*# Amount Allotted is the product of the number of Equity Shares Allotted and the Issue Price.*

*No additional uploading/processing charges shall be payable by the Company to the SCSBs on the Bid cum Application Forms directly procured by them. The selling commission payable to the SCSBs will be determined on the basis of the bidding terminal ID as captured in the Bid book of BSE or NSE.*

- 2) *Processing fees payable to the SCSBs on the portion for Retail Individual Bidders and Non-Institutional Bidders, which are procured by the members of the Syndicate/sub-Syndicate/Registered Brokers/CRTAs/CDPs and submitted to SCSBs for blocking would be as follows.*

<i>Portion for Retail Individual Bidders<sup>#</sup></i>	<i>₹ 10 per ASBA Form (plus GST)</i>
<i>Portion for Non-Institutional Bidders<sup>#</sup></i>	<i>₹ 10 per ASBA Form (plus GST)</i>

*#Based on valid Bid cum Application Forms.*

- 3) *Selling commission on the portion for Retail Individual Bidders and Non-Institutional Bidders, which are procured by members of the Syndicate (including their sub-Syndicate members), CRTAs and CDPs would be as follows:*

<i>Portion for Retail Individual Bidders<sup>#</sup></i>	<i>0.35% of the Amount Allotted (plus GST)</i>
<i>Portion for Non-Institutional Bidders<sup>#</sup></i>	<i>0.20% of the Amount Allotted (plus GST)</i>

*# Amount Allotted is the product of the number of Equity Shares Allotted and the Issue Price.*

- 4) *Bidding/uploading Charges payable to members of the Syndicate (including their Sub-Syndicate Members), Registered Brokers, CRTAs and CDPs on the portion for Retail Individual Bidders and Non-Institutional Bidders, which are procured by them and submitted to SCSB for blocking, would be ₹ 10 per valid application. The selling commission and Bidding Charges payable to the Registered Brokers, CRTAs and CDPs will be determined on the basis of the bidding terminal id as captured in the Bid Book of BSE or NSE.*

- 5) *Processing fees for applications made by Retail Individual Bidders using the UPI Mechanism will be ₹ 8/- per valid Bid cum Application Form. The Sponsor Bank shall be responsible for making payments to the third parties such as remitter bank, NPCI and such other parties as required in connection with the performance of its duties under the SEBI circulars, the Syndicate Agreement and other applicable laws.*

Except for the Regulatory related expenses, which will be borne by our Company, all other expenses relating to the Offer as mentioned above will be borne by the Company and Selling Shareholders in proportion to the Equity Shares contributed to the Offer. The Offer expenses are estimated expenses and subject to change.

The Issue expenses shall be payable within 30 working days post the date of receipt of the final invoice from the respective Intermediaries by our Company.

### **Appraisal and Bridge Loans**

Our Company has not raised any bridge loans from any bank or financial institution as on the date of this Red Herring Prospectus, which are proposed to be repaid from the Net Proceeds of the Fresh Issue.



### **Monitoring of Utilization of Funds**

Since the proceeds from the Fresh Issue do not exceed ₹ 10,000 lakhs, in terms of Regulation 16 of the SEBI Regulations, our Company is not required to appoint a monitoring agency for the purposes of this Issue. Our Board and Audit Committee will monitor the utilisation of the proceeds of the Fresh Issue. Our Company will disclose the utilization of the Net Proceeds under a separate head in our balance sheet along with the relevant details, for all such amounts that have not been utilized. Our Company will indicate investments, if any, of unutilised Net Proceeds in the balance sheet of our Company for the relevant fiscals subsequent to receipt of listing and trading approvals from the Stock Exchanges.

Pursuant to the SEBI Listing Regulations, our Company shall disclose to the Audit Committee of the Board of Directors the uses and applications of the Net Proceeds. Our Company shall prepare a statement of funds utilised for purposes other than those stated in this Red Herring Prospectus and place it before the Audit Committee of the Board of Directors, as required under applicable law. Such disclosure shall be made only until such time that all the Net Proceeds have been utilised in full. The statement shall be certified by the statutory auditor of our Company. Furthermore, in accordance with the Regulation 32(1) of the SEBI Listing Regulations, our Company shall furnish to the Stock Exchanges on a quarterly basis, a statement indicating (i) deviations, if any, in the utilisation of the proceeds of the Fresh Issue from the objects of the Fresh Issue as stated above; and (ii) details of category wise variations in the utilisation of the proceeds from the Fresh Issue from the objects of the Fresh Issue as stated above. This information will also be published in newspapers simultaneously with the interim or annual financial results, after placing the same before the Audit Committee of the Board of Directors.

### **Interim Use of Funds**

Pending utilization of the Net Proceeds for the purposes described above, our Company will deposit the Net Proceeds with scheduled commercial banks included in schedule II of the RBI Act. Our Company confirms that it shall not use the Net Proceeds for buying, trading or otherwise dealing in shares of any listed company or for any investment in the equity markets.

### **Variation in Objects**

In accordance with Section 27 of the Companies Act, 2013, our Company shall not vary the objects of the Issue without our Company being authorised to do so by the Shareholders by way of a special resolution. In addition, the notice issued to the Shareholders in relation to the passing of such special resolution shall specify the prescribed details as required under the Companies Act. The notice in respect of such resolution to Shareholders shall simultaneously be published in the newspapers, one in English and one in Regional language of the jurisdiction where our Registered Office is situated. The Shareholders who do not agree to the above stated proposal, our Promoters or controlling Shareholders will be required to provide an exit opportunity to such dissenting Shareholders, at a price as may be prescribed by SEBI, in this regard.

### **Other Confirmations**

No part of the Net Proceeds of the Fresh Issue will be paid by our Company as consideration to our Promoters, our Board of Directors, our Key Management Personnel or Group Companies except in the normal course of business and in compliance with applicable law.

## BASIS FOR OFFER PRICE

The Offer Price will be determined by our Company and the Selling Shareholders in consultation with the BRLM, on the basis of the assessment of market demand for the offered Equity Shares by the Book Building Process and on the basis of quantitative and qualitative factors as described below. The face value of the Equity Shares is ₹10 each and the Offer Price is [●] times of the face value at the lower end of the Price Band and [●] times the face value at the higher end of the Price Band.

Investors should also refer to the chapters titled “*Our Business*”, “*Risk Factors*” and “*Financial Statements*” on page nos. 130, 17 and 202, respectively, of this Red Herring Prospectus to have an informed view before making an investment decision.

### Qualitative Factors

Some of the qualitative factors and our strengths which form the basis for the Offer Price are:

- Experienced Promoters and strong Executive Team
- Wide range of products
- Integrated operations and economies of scale
- Strong Technological Capabilities
- Strategic location of our manufacturing unit
- Cordial and strong relationships with sugarcane farmers
- Captive Power plant and exportable capacity

For more details on qualitative factors, refer to chapter “*Our Business*” on page no. 130 of this Red Herring Prospectus.

### Quantitative Factors

The information presented in this section for the Fiscal ended March 31, 2019, March 31, 2018, and March 31, 2017 is derived from our Restated Financial Statements. For more details on financial information, investors please refer the chapter titled “*Financial Statements*” on page no. 202, of this Red Herring Prospectus.

Investors should evaluate our Company taking into consideration its earnings and based on its growth strategy. Some of the quantitative factors which may form the basis for computing the price are as follows:

#### 1) Basic and Diluted Earnings / Loss Per Share (“EPS”)

Year ended March 31,	Basic & Diluted	
	EPS (in ₹) <sup>(1)</sup>	Weights
2019	(5.10)	3
2018	(1.23)	2
2017	1.75	1
<b>Weighted Average</b>	<b>(2.67)</b>	

<sup>(1)</sup> Based on Restated Financials of our Company

#### Notes:

- a. Basic EPS has been calculated as per the following formula:

$$\text{Basic EPS (₹)} = \frac{\text{Net profit/ (loss) as restated, attributable to Equity Shareholders}}{\text{Weighted average number of Equity Shares outstanding during the year/period}}$$

- b. Diluted EPS has been calculated as per the following formula:

$$\text{Diluted EPS (₹)} = \frac{\text{Net profit/ (loss) as restated, attributable to Equity Shareholders}}{\text{Diluted Weighted average number of Equity Shares outstanding during the year/period}}$$

- c. Basic and Diluted EPS calculations are in accordance with Indian Accounting Standard 33 (IND AS 33) “Earnings per Share”, notified under section 133 of Companies Act, 2013 read together along with paragraph 7 of Companies (Accounting) Rules, 2014
- d. The above statement should be read in conjunction with Significant Accounting Policies and Notes to Restated Financial Statements as appearing in “Annexure V & VI - Financial Information” on page no. 202 Red Herring Prospectus.

**2) Price Earnings Ratio (“P/E”) in relation to the Price Band of ₹ [●] to ₹ [●] per share of ₹ 10 each**

Particulars	P / E Ratio
P/E ratio based on basic and diluted EPS for the year ended March 31, 2019 at the Lower end of the price band	N. A.
P/E ratio based on weighted average EPS for the year ended March 31, 2019 at the Lower end of the price band	N. A.
P/E ratio based on basic and diluted EPS for the year ended March 31, 2019 at the Higher end of the price band	N. A.
P/E ratio based on weighted average EPS for the year ended March 31, 2019 at the Higher end of the price band	N. A.

*Note: Since the Basic and Diluted EPS for the year ended March 31, 2019 and the Weighted average EPS for the year ended March 31, 2019 is negative, these figures are not computable.*

Industry P/E <sup>(1)</sup>	
Highest – Bannari Amman Sugars Ltd.	20.0
Lowest – Dalmia Bharat Sugar and Industries Ltd.	3.6
Industry Average	6.0

<sup>(1)</sup> Source: Capital Market, Vol. XXXIV/14, Aug 26 – Sep 08, 2019; Segment: Sugar

**3) Return on Networth (RoNW)**

Year ended March 31,	RoNW (%)	Weight
2019	(8.33)%	3
2018	(1.86)%	2
2017	2.61%	1
<b>Weighted Average</b>	<b>(4.35)%</b>	

**Note:** Return on Net worth has been calculated as per the following formula:

$$\text{RoNW} = \frac{\text{Net profit/loss after tax, as restated}}{\text{Net worth excluding preference share capital and revaluation reserve}}$$

**4) Minimum Return on Net Worth after Offer needed to maintain Pre-Offer EPS for the year ended March 31, 2019**

Particulars	Minimum RoNW (%) at the Lower end of the price band	Minimum RoNW (%) at the Higher end of the price band
To maintain Pre-Offer basis & diluted EPS for the year ended March 31, 2019	NA	NA

*Note: Since the Basic and Diluted EPS for the year ended March 31, 2019 is negative, these figures cannot be computed.*

**Note:**

*Net worth is the sum of the share capital, the reserves and the surplus less miscellaneous expenditure not written off.*

## 5) Net Asset Value (NAV)

Financial Year	NAV (₹)
NAV as at March 31, 2019	61.20
NAV after Offer	[●]
Offer Price (₹)	[●]

**Note:** Net Asset Value has been calculated as per the following formula:

$$\text{NAV} = \frac{\text{Net worth excluding preference share capital and revaluation reserve}}{\text{Outstanding number of Equity shares at the end of the year}}$$

## 6) Comparison with Industry Peers

We believe following is our peer group which has been determined on the basis of listed public companies comparable in the similar line of segments in which our Company operates i.e. Sugar, whose business segment in part or full may be comparable with that of our business, however, the same may not be exactly comparable in size or business portfolio on a whole with that of our business.

Name of the Company	EPS	Face Value (₹)	P/E Ratio <sup>(2)</sup>	RoNW <sup>(3)(4)</sup> (%)	NAV Per Share <sup>(5)</sup> (₹)
<b>Peer Group<sup>(1)</sup></b>					
Ugar Sugar Works Ltd.	0.39	1.00	33.08	8.50%	4.54
Dwarikesh Sugar Industries Ltd	5.05	1.00	4.45	20.51%	24.62
Balrampur Chini Mills Ltd	24.98	1.00	5.67	27.40%	91.19
Dhampur Sugar Mill Ltd	38.40	10.00	4.17	20.51%	187.07
<i>Source: Financial Results / Annual Report of the Company filed with the Stock Exchanges</i>					
<b>The Company</b>					
Vishwaraj Sugar Industries Limited	(5.10)	10.00	N. A. <sup>#</sup>	(8.33)%	61.20
<i>Source: Restated Financials of the Company as disclosed on page no. 202 of this Red Herring Prospectus.</i>					

<sup>#</sup> Since the Basic and Diluted EPS for the year ended March 31, 2019 is negative, this figures are not computable.

### Note:

- 1) The peer group figures based on audited standalone financials as on and for the year ended March 31, 2019.
- 2) P/E figures for the peer is computed based on closing market price as on July 31, 2019, of relevant peer companies as available at BSE, (available at [www.bseindia.com](http://www.bseindia.com)) divided by Basic EPS for FY 19 reported in the filings made with stock exchanges.
- 3) Net Worth = Equity Share Capital + Securities Premium Account + General Reserve + Surplus / (Deficit) in the statement of profit and loss + Reserves created out of profits but does not include revaluation reserve.
- 4) Return on net worth (%) = Net profit after tax \* 100 / Net worth at the end of the year
- 5) Net Asset value per share = Net worth at the end of the year / No. of shares outstanding at the end of year

- 7) The Floor Price of ₹ [●] and the Cap Price of ₹ [●] has been determined by our Company and the Selling Shareholders in consultation with the Book Running Lead Manager on the basis of the assessment of market demand from investors for the Equity Shares determined through the Book Building Process and is justified based on the above qualitative and quantitative parameters. Investor should read the above mentioned information along with the section titled "Risk Factors" on page no. 17 of this Red Herring Prospectus and the financials of our Company including important profitability and return ratios, as set out in the section titled "Financial Statements" on page no. 202 of this Red Herring Prospectus. The trading price of the Equity Shares could decline due to the factors mentioned in section titled "Risk Factors" on page no. 17 of this Red Herring Prospectus and an investor may lose all or part of his investment.

## BASIC TERMS OF THE OFFER

### Terms of the Offer

The Equity Shares being offered are subject to the provisions of the Companies Act, our Memorandum and Articles of Association, the terms of the Draft Red Herring Prospectus, the Red Herring Prospectus, the Prospectus, Bid cum Application Form, the Revision Form, the Confirmation of Allocation Note and other terms and conditions as may be incorporated in the allotment advices and other documents/certificates that may be executed in respect of the Offer. The Equity Shares shall also be subject to laws as applicable, guidelines, notifications and regulations relating to the issue of capital and listing and trading of securities issued from time to time by SEBI, the Government of India, the Stock Exchanges, the RBI, RoC and/or other authorities, as in force on the date of the Offer and to the extent applicable.

### Other Details

<b>Authority for the Offer</b>	<p>The Offer has been approved by a resolution of the Board of Directors under section 62 (1)(C) passed at their meeting held on November 20, 2017. The shareholders of our Company authorized and approved this Offer under section 62(1)(C) of the Companies Act, 2013 by a special resolution at the extra-ordinary general meeting of our Company held on December 18, 2017.</p> <p>The Selling Shareholders, pursuant to the Selling Shareholders' Consent Letters, have given their consent to offer their Equity Shares in the Offer.</p>
<b>Face Value</b>	The Equity Shares to be issued pursuant to this Offer, having a face value of ₹ 10/- each are being offered in terms of this Red Herring Prospectus at a price of ₹ [●] per Equity Share. Subject to applicable laws, there shall be, at any given point of time, only one denomination of the Equity Shares of our Company.
<b>Offer Price per Share</b>	<i>Price Band:</i> ₹ [●] to ₹ [●] per Equity share of face value of ₹ 10/- each. The Floor Price is [●] times of the face value and the Cap Price is [●] times the Face Value.
<b>Terms of Payment</b>	<p>Applications should be for a minimum of [●] equity shares and [●] equity shares thereafter. The entire price of the equity shares of ₹ [●] per share (₹ 10/- face value + ₹ [●] premium) is payable on application.</p> <p>In case of allotment of lesser number of equity shares than the number applied, the excess amount paid on application shall be refunded by us to the applicants.</p>
<b>Ranking of the Equity Shares</b>	The Equity Shares issued pursuant to this Offer shall be subject to the Memorandum and Articles of Association of the Company and shall rank <i>pari - passu</i> in all respects including dividends with the existing Equity Shares of the Company. The allottees will be entitled to dividend, voting rights or any other corporate benefits, if any, declared by us after the date of Allotment.
<b>Market Lot and Trading Lot</b>	<p>In terms of Section 29 of the Companies Act, 2013, the Equity Shares shall be allotted only in dematerialised form. In terms of existing SEBI Guidelines, the trading in the Equity Shares shall only be in dematerialised form for all investors.</p> <p>Since trading of the Equity Shares will be in dematerialized mode, the tradable lot is one Equity Share. Allocation and allotment of Equity Shares through this Offer will be done only in electronic form in multiples of 1 Equity Share subject to a minimum allotment of [●] Equity Shares to the successful bidders.</p>

### Minimum Subscription

If our Company does not receive (i) the minimum subscription of 90% of the Fresh Issue; and (ii) a subscription in the Issue equivalent to at least 25% post- Issue paid up Equity Share capital of our Company (the minimum number of securities as specified under Rule 19(2)(b)(i) of the SCRR), including devolvement of Underwriters, if any, within 60 days from the date of Bid/Offer Closing Date, our Company shall forthwith refund the entire subscription amount received. If there is a delay beyond the prescribed time, our Company shall pay interest prescribed under the Companies Act, 2013, the SEBI ICDR Regulations and applicable law. The requirement for minimum subscription is not applicable to the Offer for Sale. In case of an under subscription in the Issue, the Equity Shares in the Fresh Issue will be issued prior to the sale of Equity Shares in Offer for Sale by the Selling Shareholder.

Further, in accordance with Regulation 26(4) of the SEBI ICDR Regulations, our Company shall ensure that the number of prospective allottees to whom the Equity Shares will be Allotted will be not less than 1,000 otherwise, the

---

entire application money will be refunded forthwith. If there is a delay beyond 6 (six) working days after we become liable to pay the amount, we shall pay interest at the rate of 15% per annum for the delayed period.

Any expense incurred by our Company on behalf of the Selling Shareholders with regard to refunds, interest for delays, etc. for the Equity Shares being offered in the Issue will be reimbursed by the Selling Shareholders to our Company in proportion to the Equity Shares being offered for sale by the Selling Shareholders in the Issue.



## STATEMENT OF TAX BENEFITS

To,  
The Board of Directors,  
**Vishwaraj Sugar Industries Limited**  
Bellad Bagewadi,  
Taluka Hukkeri,  
District Belgaum - 591305

Dear Sirs,

**Subject: Statement of Possible Special Tax Benefits available to Vishwaraj Sugar Industries Limited and its shareholders prepared in accordance with the requirements under Schedule VIII – Clause (VII) (L) of the SEBI ICDR Regulations**

We hereby report that the enclosed annexure prepared by Vishwaraj Sugar Industries Limited, states the possible special tax benefits available to Vishwaraj Sugar Industries Limited ('the Company') and the shareholders of the Company under the Income Tax Act, 1961 ('Act'), presently in force in India. Several of these benefits are dependent on the Company or its shareholders fulfilling the conditions prescribed under the relevant provisions of the Act. Hence, the ability of the Company or its shareholders to derive the special tax benefits is dependent upon fulfilling such conditions, which based on the business imperatives, the company may or may not choose to fulfil.

The benefits discussed in the enclosed Annexure cover only special tax benefits available to the Company and the Shareholders and do not cover any general tax benefits available to the Company and the Shareholders. Further, the preparation of enclosed statement and the contents stated therein is the responsibility of the Company's management. We are informed that, this Statement is only intended to provide general information to the investors and is neither designed nor intended to be a substitute for professional tax advice. In view of the individual nature of the tax consequences and the changing tax laws, each investor is advised to consult his or her own tax consultant with respect to the specific tax implications arising out of their participation in the proposed initial public offering of equity shares ("the Offer") by the Company.

We do not express any opinion or provide any assurance as to whether:

- a) The Company or its Equity Shareholders will continue to obtain these benefits in future; or
- b) The conditions prescribed for availing the benefits have been / would be met with.

The contents of the enclosed statement are based on information, explanations and representations obtained from the Company and on the basis of our understanding of the business activities and operations of the Company.

Our views are based on facts and assumptions indicated to us and the existing provisions of tax law and its interpretations, which are subject to change or modification from time to time by subsequent legislative, regulatory, administrative, or judicial decisions. Any such changes, which could also be retrospective, could have an effect on the validity of our views stated herein. We assume no obligation to update this statement on any events subsequent to its Offer, which may have a material effect on the discussions herein.

This report including enclosed annexure are intended solely for your information and for the inclusion in the Red Herring Prospectus / Prospectus or any other Offer related material in connection with the proposed initial public offer of the Company and is not to be used, referred to or distributed for any other purpose without our prior written consent.

For **M/s. Gojanur & Co, Chartered Accountants**  
**Firm Registration No.: 000941S**

Sd/-  
**G. M. Channappa Shetty**  
**Membership No: 020227**  
Place: Shivamogga  
Date: July 08, 2019

---

## ANNEXURE TO THE STATEMENT OF TAX BENEFITS

**You should consult your own tax advisors concerning the Indian Tax implications and consequences of purchasing, owning and disposing of Equity Shares in your particular situation.**

### A. SPECIAL TAX BENEFITS TO THE COMPANY

The Company is entitled to deduction under the sections mentioned hereunder from its total income chargeable to Income Tax

1. Deduction under Section 80IA – Where the gross total income of the Company includes any profits and gains derived from generation or transmission or distribution of power, it shall in accordance with and subject to the provisions of section 80IA, be allowed, in computing the total income of the Company, a deduction of an amount equal to hundred per cent of the profits and gains derived from such business for ten consecutive assessment years within 15 Assessment Years from initial Assessment Year.

### B. SPECIAL TAX BENEFITS TO THE SHAREHOLDER

NIL

#### Note:

1. The statement of tax benefits enumerated above is as per the Income Tax Act 1961 including amendments as set out in the Finance Act 2019.
2. The above statement covers only certain relevant direct tax law benefits and does not cover any indirect tax law benefits or benefit under any other law.
3. This statement is only intended to provide general information to the investors and is neither designed nor intended to be a substitute for professional tax advice. In view of the individual nature of the tax consequences, the changing tax laws, each investor is advised to consult his or her own tax consultant with respect to the specific tax implications arising out of their participation in the Offer.
4. We have not commented on the taxation aspect under any law for the time being in force, as applicable, of any country other than India. Each investor is advised to consult its own tax consultant for taxation in any country other than India.

## SECTION V: ABOUT OUR COMPANY

### INDUSTRY OVERVIEW

*The information in this chapter has been extracted from websites and publicly available documents from various sources. The data may have been re-classified by us for the purpose of presentation. Neither we nor any other person connected with this Issue has independently verified the information provided in this chapter. Industry sources and publications, referred to in this chapter, generally state that the information contained therein has been obtained from sources generally believed to be reliable but their accuracy, completeness and underlying assumptions are not guaranteed and their reliability cannot be assured. Industry sources and publications may also base their information on estimates, projections, forecasts and assumptions that may prove to be incorrect. Industry publications are also prepared based on information as of specific dates and may no longer be current or reflect the current trends. Accordingly, investors should not place undue reliance on, or base their investment decision on this information. The information in this section must be read in conjunction with the sections titled “Risk Factors” and “Our Business” beginning on page nos. 17 and 130, respectively.*

#### Global Economic Overview

After strong growth in 2017 and early 2018, global economic activity slowed notably in the second half of last year, reflecting a confluence of factors affecting major economies. China’s growth declined following a combination of needed regulatory tightening to rein in shadow banking and an increase in trade tensions with the United States. The euro area economy lost more momentum than expected as consumer and business confidence weakened and car production in Germany was disrupted by the introduction of new emission standards; investment dropped in Italy as sovereign spreads widened; and external demand, especially from emerging Asia, softened. Elsewhere, natural disasters hurt activity in Japan. Trade tensions increasingly took a toll on business confidence and, so, financial market sentiment worsened, with financial conditions tightening for vulnerable emerging markets in the spring of 2018 and then in advanced economies later in the year, weighing on global demand. Conditions have eased in 2019 as the US Federal Reserve signalled a more accommodative monetary policy stance and markets became more optimistic about a US China trade deal, but they remain slightly more restrictive than in the fall.

Global growth is expected to level off in the first half of 2019 and firm up after that.

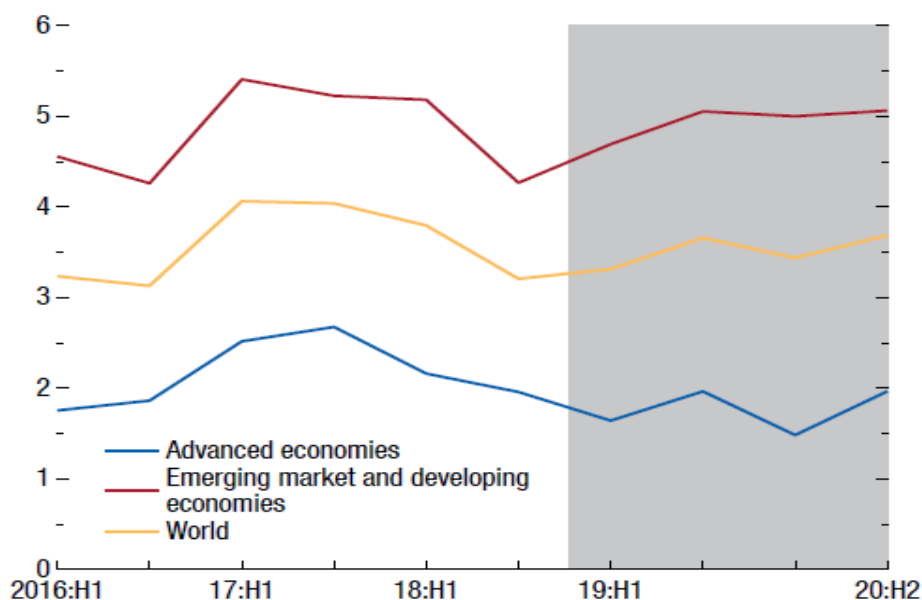

Beyond 2020, global growth is set to plateau at about 3.6 percent over the medium term, sustained by the increase in the relative size of economies, such as those of China and India, which are projected to have robust growth by comparison to slower-growing advanced and emerging market economies (even though Chinese growth will eventually moderate). Tepid labour productivity growth and slowing expansion of the labour force amid population aging will drag advanced economy growth lower over the projection horizon. Growth across emerging market and developing economies is projected to stabilize slightly below 5 percent, though with variations by region and country. The baseline outlook for emerging Asia remains favourable, with China’s growth projected to slow gradually toward sustainable levels and convergence in frontier economies toward higher income levels. For other regions, the outlook is

complicated by a combination of structural bottlenecks, slower advanced economy growth and, in some cases, high debt and tighter financial conditions. These factors, alongside subdued commodity prices and civil strife or conflict in some cases, contribute to subdued medium-term prospects for Latin America; the Middle East, North Africa, and Pakistan region; and parts of sub-Saharan Africa. In particular, convergence prospects are bleak for some 41 emerging market and developing economies, accounting for close to 10 percent of global GDP in purchasing-power-parity terms and with total population close to 1 billion, where per capita incomes are projected to fall further behind those in advanced economies over the next five years.

(Source: “World Economic Outlook, April 2019 Growth Slowdown, Precarious Recovery” by International Monetary Fund)

## Indian Economy Overview

Economic growth will slow somewhat but remain robust, at close to 7½ per cent in 2019 and 2020. Higher oil prices and the rupee depreciation are putting pressure on demand, inflation, the current account and public finances. However, business investment and exports will be strong, as past structural reforms – including the new Insolvency and Bankruptcy Code, smoother implementation of the Goods and Services Tax (GST), better roads and electricity and bank recapitalisation – are paying off.

Monetary policy will need to be tightened as inflation expectations are trending up and there are several upside risks to inflation. Containing the relatively high public debt-to-GDP ratio would require controlling contingent liabilities, such as those stemming from public enterprises and banks. Further subsidy reform would help make social spending more effective. Improving public banks’ governance is also key to avoid a new wave of non-performing loans and to support the investment recovery.

Investment is growing steadily, driven by the gradual increase in capacity utilisation, large infrastructure programmes and recent structural reforms which are supporting investors’ confidence, in particular the new Insolvency and Bankruptcy Code and public bank re-capitalisation. The rebound in exports is supported by a weaker rupee and an easier-to-comply-with Goods and Services Tax. Private consumption remains strong, in particular in rural areas where incomes are benefitting from the good monsoon and steady government spending on rural roads, housing and employment programs.

Consumer price inflation remains within the target band, partly reflecting one-off factors, such as a good monsoon, lower excise taxes on oil products and the government’s request to public-sector oil marketing companies to lower their margins. However, pressures on inflation are rising from the rupee depreciation and recent increases in wages and housing allowances for public employees. Core inflation and inflation expectations are edging up.

The current account deficit is increasing, driven by India’s growth differential with other economies and higher oil prices. Financing the deficit is becoming more challenging as foreign direct investment inflows are sluggish and portfolio capital is being pulled out by higher yields in advanced economies. The government has hiked import duties to limit the current account deficit and lessened constraints on firms’ external borrowing. The depreciation of the real effective exchange rate remains moderate. External vulnerability is now less of a concern than in previous episodes of financial turmoil as macroeconomic fundamentals have improved and foreign exchange reserves have been replenished.

Growth is projected to remain strong in 2019 and 2020. Tighter financial conditions, higher oil prices, adverse terms of trade, lower growth in partner countries, and rising political uncertainties in India and abroad will tend to reduce growth somewhat. Even so, economic activity is projected to slow only marginally from a high level. Recent improvements in the GST administration, enabling exporters to get faster tax refunds, and the depreciation of the rupee will boost exports. Corporate investment will remain vigorous, supported by recent structural reforms and better infrastructure (in particular road and energy provision). Inflation pressures will be reinforced by the decision to raise minimum support prices and government purchases of some agricultural products. The Reserve Bank’s credibility in targeting inflation and the projected marginal increases in policy rates will help anchor inflation. Confidence and investment would suffer from unexpected difficulties in non-bank financial institutions and delays in reducing non-performing loans. A further increase in oil prices and contagion from turbulence in other emerging-market economies are the major external risks. On the other hand, the hike in US tariffs on Chinese imports could benefit India’s exports, in particular in the textile sector.

Tighter financial conditions, higher oil prices, adverse terms of trade, lower growth in partner countries, and rising political uncertainties in India and abroad will tend to reduce growth somewhat. Even so, economic activity is projected to slow only marginally from a high level. Recent improvements in the GST administration, enabling exporters to get

faster tax refunds, and the depreciation of the rupee will boost exports. Corporate investment will remain vigorous, supported by recent structural reforms and better infrastructure (in particular road and energy provision). Inflation pressures will be reinforced by the decision to raise minimum support prices and government purchases of some agricultural products. The Reserve Bank's credibility in targeting inflation and the projected marginal increases in policy rates will help anchor inflation. Confidence and investment would suffer from unexpected difficulties in non-bank financial institutions and delays in reducing non-performing loans. A further increase in oil prices and contagion from turbulence in other emerging-market economies are the major external risks. On the other hand, the hike in US tariffs on Chinese imports could benefit India's exports, in particular in the textile sector.

(Source: <http://www.oecd.org/eco/outlook/economic-forecast-summary-india-oecd-economic-outlook.pdf>)

## India: Demand, output and prices

	2015	2016	2017	2018	2019	2020
	Current prices INR trillion	Percentage changes, volume (2012/2013 prices)				
<b>GDP at market prices</b>	137.6	7.1	6.7	7.5	7.3	7.4
Private consumption	80.9	7.3	6.6	7.2	7.4	7.4
Government consumption	14.3	12.2	10.9	7.0	7.3	5.3
Gross fixed capital formation	39.2	10.1	7.6	6.2	6.0	8.6
Final domestic demand	134.4	8.6	7.3	6.9	7.0	7.5
Stockbuilding <sup>1</sup>	6.4	-1.2	0.0	0.1	0.0	0.0
Total domestic demand	140.8	6.9	8.1	8.3	6.9	7.5
Exports of goods and services	27.3	5.0	5.6	8.9	4.5	6.3
Imports of goods and services	30.4	4.0	12.4	12.0	3.4	6.9
Net exports <sup>1</sup>	-3.2	0.1	-1.5	-0.9	0.1	-0.3
<i>Memorandum items</i>						
GDP deflator	—	3.5	3.1	4.9	4.7	4.3
Consumer price index	—	4.5	3.6	4.5	5.0	4.5
Wholesale price index <sup>2</sup>	—	1.7	2.9	4.8	4.6	4.3
General government financial balance <sup>3</sup> (% of GDP)	—	-7.0	-6.6	-6.4	-6.2	-6.0
Current account balance (% of GDP)	—	-0.6	-1.9	-2.1	-2.8	-3.0

Note: Data refer to fiscal years starting in April.

1. Contributions to changes in real GDP, actual amount in the first column.

2. WPI, all commodities index.

3. Gross fiscal balance for central and state governments.

Source: OECD Economic Outlook 104 database.

StatLink  <http://dx.doi.org/10.1787/888933877791>

## INDIAN SUGAR INDUSTRY

India is at the cusp of another bumper sugar production phase recording, 32-33mnt (vs. consumption of 25-26mnt) in the coming season (Oct'18-Sep'19); this would be led by Uttar Pradesh (UP; higher acreage and yields), but partially offset by Maharashtra (lower yield). Despite record cane arrears, we believe farmers should continue to plant sugarcane crops given robust profitability (vs. alternatives) and assured offtake/cash flows.

The government continues to provide support to the industry through various measures including regulating the minimum selling price (MSP) of sugar, soft loans, export subsidies, cane price assistance, higher ethanol pricing and blending mandates. However, we believe ethanol is unlikely to break the cyclical nature of the sugar sector given its limited impact on sugar production.

After posting record sugar production of 32.2mnt in SS18 (+60% YoY; last peak of 28.3mnt in SS15), India is expected to produce another similar quantum (32-33mnt) in SS19, led by a) higher acreage and yield in UP (growing adoption of

new 'early variety' sugarcane) and b) higher acreage in MH and Karnataka (good monsoon in 2017), offset by lower yields due to pest attacks/drought in key pockets of production. Even after assuming 5mnt of exports, India is likely to end with closing stock of 12mnt in Sep'19, almost 6-7 months' consumption). Moreover, considering the nature of the crop (long duration and sturdy, assured cash flows, adoption of the early variety of sugarcane) and robust profitability, we believe India should mostly have an excess supply scenario, except in case of severe drought or pest attacks. (Source: Sector Update – India Sugar; A New Saviour for The Sugar Industry?; JM Financial; October 2018)

India's centrifugal sugar (henceforth sugar) production in Marketing Year 2018/19 (Oct-Sept) is expected to rise 4.2 percent to a record 33.8 million metric tons (MMT). Uttar Pradesh will be the largest producer of sugar in India, for the third year in a row. A higher sugarcane production forecast of 415 MMT on 5.2 million hectares (MH) will contribute to the above estimates. Assuming normal market conditions, sugar mills will be encouraged to use up surplus inventory of up to 6 MMT. With incentives, this surplus could be exported, as out-year sugar supply will be 31 percent over consumption and normal stock requirements (34.4 MMT).

(Source: USDA Foreign Agricultural Services – Global Agricultural Information Network – India Sugar Annual 2018; [https://gain.fas.usda.gov/Recent%20GAIN%20Publications/Sugar%20Annual\\_New%20Delhi\\_India\\_4-10-2017.pdf](https://gain.fas.usda.gov/Recent%20GAIN%20Publications/Sugar%20Annual_New%20Delhi_India_4-10-2017.pdf))

## Production

As on 15th December, 2018, 462 sugar mills were crushing sugarcane for the year 2018-19 and they have produced 70.52 lakh tons of sugar, i.e. 1.48 lakh tons (2.1%) higher than the sugar production on the corresponding date of previous sugar season, of 69.04 Lakh tons of sugar. Last year on the corresponding date, 476 mills were operating.

(Source: [https://www.business-standard.com/article/news-cm/india-s-sugar-production-up-2-1-in-2018-19-sugar-season-so-far-118121900273\\_1.html](https://www.business-standard.com/article/news-cm/india-s-sugar-production-up-2-1-in-2018-19-sugar-season-so-far-118121900273_1.html))

Marketing Year 2018/19 centrifugal sugar (henceforth sugar) production is forecast to rise 4.3 percent to a record 33.8 MMT, which includes 560,000 metric tons (MT) of khandsari (a local type of low-recovery sugar prepared by open-pan evaporation) and 31.1 MMT of milled sugar (33.3 MMT raw equivalent) (Table 4). An expectation of an improved sugar recovery rate for the second consecutive year, increases in cane crushing volume as a result of larger cane production, and assumed benefits from higher cane by-product production (for integrated mills) should encourage higher sugar production.

However, declining sugar prices in conjunction with a rising Fair and Remunerative Price (FRP)/State Advised Price (SAP) for MY 2017/18 (Table 7) has increased the backlog of the sugar companies' dues payable to the farmers in the ongoing season, particularly in states where cane costs are not directly linked to Revenue Sharing Formula (RSF). In latter case, farmers are paid the FRP as a first installment; if dues to farmers under the RSF are more than the FRP, than they will be entitled to a second payment.



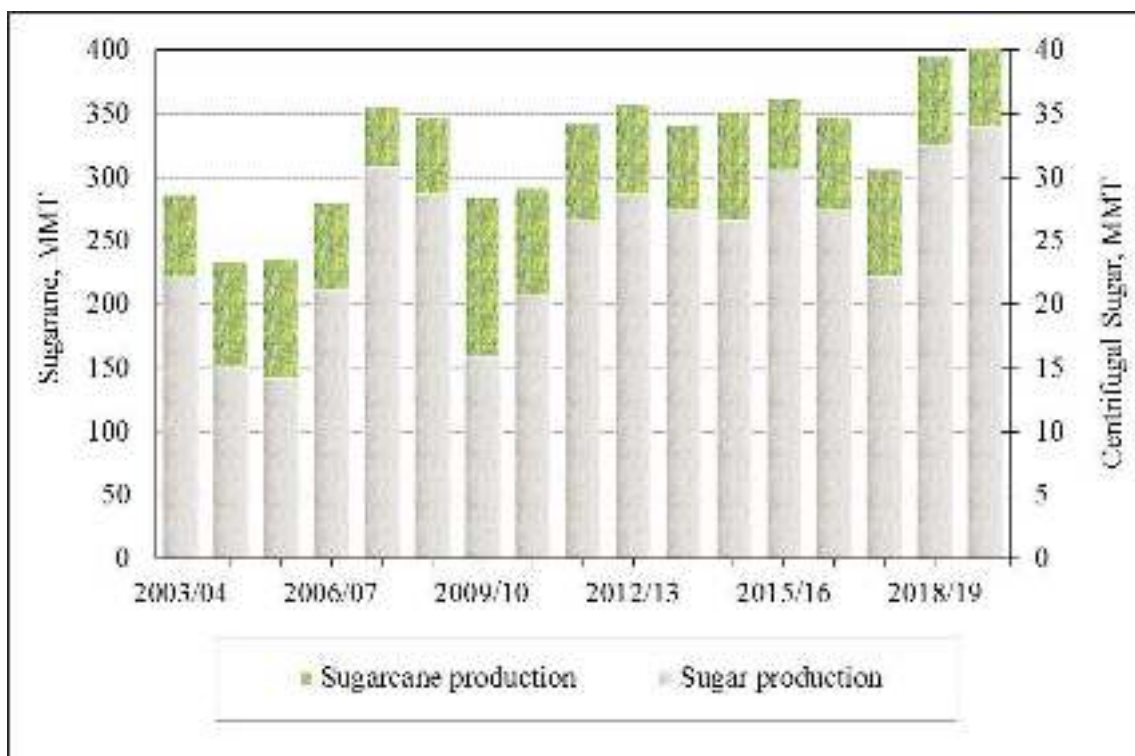

### Consumption

Out-year sugar consumption is forecast at 27.5 MMT, four percent above the current year estimate of 26.5 MMT. A strong demand from bulk buyers, food processors, quick service restaurants, sweet meat shops, households, a growing population, rising income and changing food consumption patterns should support higher consumption in the out-year. Bulk users account for two-third of total sugar consumption in India. In addition to the above, most khandasari sugar is consumed by local sweet shops and gur is mostly consumed in rural households for food, and feed use as well.

(Source: USDA Foreign Agricultural Services – Global Agricultural Information Network – India Sugar Annual 2018; [https://gain.fas.usda.gov/Recent%20GAIN%20Publications/Sugar%20Annual\\_New%20Delhi\\_India\\_4-10-2017.pdf](https://gain.fas.usda.gov/Recent%20GAIN%20Publications/Sugar%20Annual_New%20Delhi_India_4-10-2017.pdf))

Most khandasari sugar is consumed by local sweet shops and gur is mostly consumed in rural households and for feed use. India’s stable economy, rising incomes, growing young population, and changing consumption patterns are key drivers for food consumption.

### Market Prices

Sugar prices dropped more than 21 percent in the last 6 months due to more than sugar production in MY 2017/18. Compared to the corresponding period last year, sugar prices are down 7 percent despite firm Indian demand during the festival season (September – February). In fact, before falling, sugar prices (wholesale) rallied 62 percent in the last 27 months to peak at INR 40,300 per MT in October 2017.

Generally, gur prices move in tandem with sugar prices, either at a premium or at a discount. At current price levels it is selling at a discount to \$60 per MT to sugar (quoted at \$486 per MT). In fact, gur prices fell 26 percent in the last seven months in response to surplus cane production (Figure 2). Gur prices will follow domestic and international price movement for its future direction.

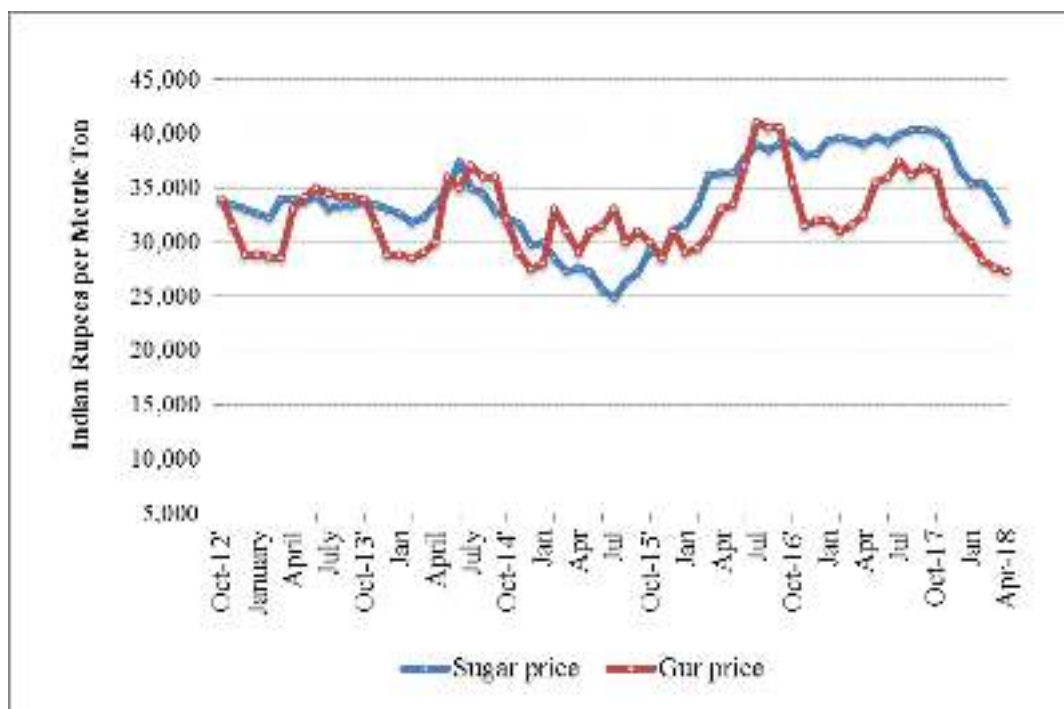

#### Trade:

Assuming normal market conditions, sugar mills will be encouraged to use up surplus inventory, up to 6 MMT. With incentives, this surplus could be exported, as out-year sugar supply will be in excess of 31 percent over consumption and normal stock requirements (34.4 MMT). The commercial export basket will ideally include raw and white sugar in equal proportion. Imports are likely to be negligible as a result.

Post estimates that sugar exports in MY 2017/18 will be close to 2 MMT of which an estimated 1 MMT will be sugar re-exported under the Advance Authorization Scheme (AAS), and the other half (1 MMT) will be commercial sales. If this is accurate, then 300,000 MT of raw and 700,000 MT of white sugar sales looks plausible, but only with incentives as Indian sugar prices are not competitive at the moment (Industry Source). Concurrently, sugar imports in MY 2017/18 are estimated at 1 MMT which is also under the AAS. Trade data suggest that an estimated 550,000 MT was imported in the last 6 months (Oct-March). India mostly imports sugar from Brazil, however other countries such as the UAE, Germany, Italy, France and lately the United States (average annual sales of 130 MT to 190 MT, HS Code: 170199) have started to ship small volumes to India. Myanmar, Sudan, Somalia, UAE, Kenya, Saudi Arabia, and neighbours are important buyers of Indian sugar.

Last year, India imported 2.7 MMT of sugar of which 0.725 MMT was imported under Open General License (OGL) and the remaining under the AAS. Under OGL, an estimated 0.5 MMT was imported at zero percent import duty, of which 480,000 MT actually arrived. Another 300,000 MT was slated for import at 25 percent import duty, of which 245,000 MT was actually imported, thus bringing the total to 725,000 MT. Sugar (refined) re-exports under AAS is reported at 2.15 MMT.

(Source: USDA Foreign Agricultural Services – Global Agricultural Information Network – India Sugar Annual 2018; [https://gain.fas.usda.gov/Recent%20GAIN%20Publications/Sugar%20Annual\\_New%20Delhi\\_India\\_4-10-2017.pdf](https://gain.fas.usda.gov/Recent%20GAIN%20Publications/Sugar%20Annual_New%20Delhi_India_4-10-2017.pdf))

#### Shift to Ethanol

In order to reduce cane arrears and achieve bio-fuel targets, the government has stepped up on ethanol procurement through

- higher ethanol pricing (INR 43.7/litre vs INR 40.8/ litre earlier) and
- Authorising the use of B Heavy molasses as well as sugarcane for ethanol production and accorded priority in procurement.

While the B Heavy molasses and direct sugarcane juice route are viable at current sugar/ethanol prices, we believe the impact on sugar production can be at best 1mnt in 2018-19 and probably 2-3mnt over the medium term considering

capacity constraints, geographical spread and industry dynamics (fragmented industry, competing demand from industrial/potable alcohol, historical unsteady EBP implementation, etc.)

**Exhibit 1. Alcohol Consumption mix and Ethanol Blending (%)**

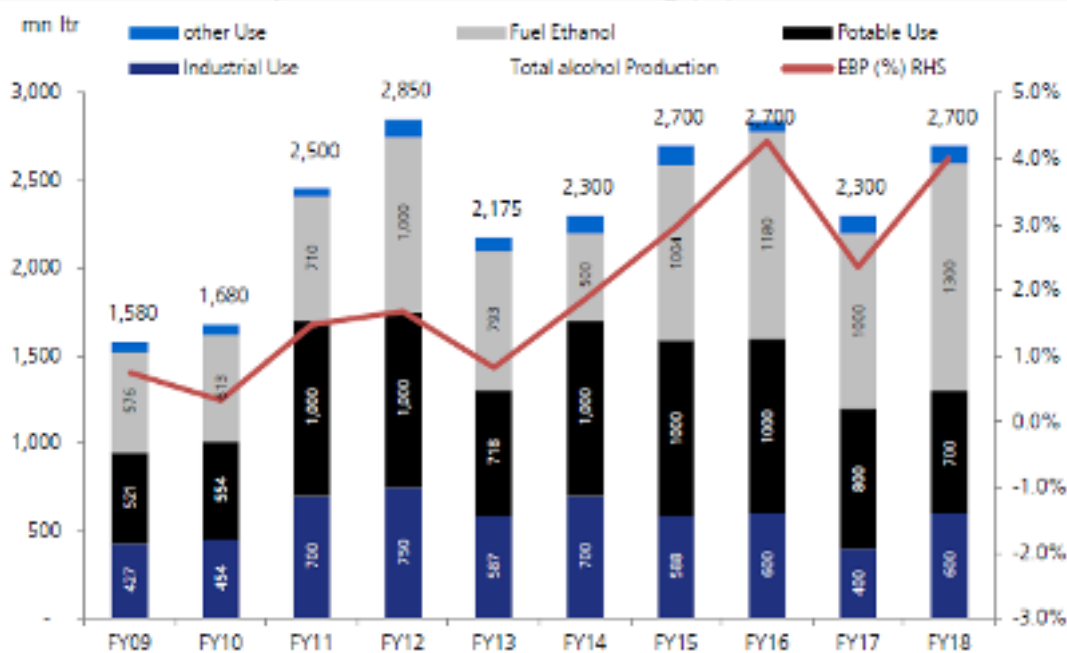

**Exhibit 2. B Molasses and Direct route are viable at current sugar/ethanol prices**

	Unit	Conventional C Molasses	B Molasses	Direct route
cane crushed	tonnes	100	100	100
Sugar recovery rate	%	10.37	8.82	-
Molasses recovery rate	%	4.50	6.58	75 litres per tonne of cane
Ethanol recovery (per tonne of molasses)	Litres	240	295	
<b>Volume</b>				
Sugar	Tonnes	10.37	8.82	-
Ethanol	Litres	1,080	1,941	7,500
<b>Realisation</b>				
Sugar	INR/Kg	29.0	29.0	-
Ethanol	INR/ltr	43.2	52.0	59.0
Profit	INR	-12,013	2,701	81,344
<b>Incremental profit over C molasses route</b>	<b>INR</b>		<b>14,714</b>	<b>93,357</b>

(Source: Sector Update – India Sugar; A New Saviour for The Sugar Industry?; JM Financial; October 2018)

### Regulations in Sugar Industry

With the amendment of the Sugarcane (Control) Order, 1966 on 22.10.2009 and the concept of Statutory Minimum Price (SMP) of sugarcane was replaced with the 'Fair and Remunerative Price (FRP) of sugarcane for 2009-10 and subsequent sugar seasons. The cane price announced by the Central Government is decided on the basis of the recommendations of the Commission for Agricultural Costs and Prices (CACP) after consulting the State Governments and associations of sugar industry. The amended provisions of the Sugarcane (Control) Order, 1966 provides for fixation of FRP of sugarcane having regard to the following factors:-

- (a) Cost of production of sugarcane;

- (b) Return to the growers from alternative crops and the general trend of prices of agricultural commodities;
- (c) Availability of sugar to consumers at a fair price;
- (d) Price at which sugar produced from sugarcane is sold by sugar producers;
- (e) Recovery of sugar from sugarcane;
- (f) The realization made from sale of by-products viz. molasses, bagasse and press mud or their imputed value and
- (g) Reasonable margins for the growers of sugarcane on account of risk and profits.

Under the FRP system, the farmers are not required to wait till the end of the season or for any announcement of profits by sugar mills or the Government. The new system also assures margins on account of profit and risk to farmers, irrespective of the fact whether sugar mills generate profit or not and is not dependent on the performance of any individual sugar mill.

In order to ensure that higher sugar recoveries are adequately rewarded and considering variations amongst sugar mills, the FRP is linked to a basic recovery rate of sugar, with a premium payable to farmers for higher recoveries of sugar from sugarcane.

(Source: <https://dfpd.gov.in/sugar.htm>)

Keeping in view the interest of sugarcane farmers, the Cabinet Committee on Economic Affairs chaired by Prime Minister Shri Narendra Modi has approved the Fair and Remunerative Price (FRP) of sugarcane for sugar season 2018-19 at ₹ 275/- per quintal for a basic recovery rate of 10%; providing a premium of ₹ 2.75/ql for each 0.1 % increase in recovery over and above 10%. The cost of production of sugarcane for the sugar season 2018-19 is ₹ 155 per quintal.

(Source: <http://pib.nic.in/PressReleaseIframePage.aspx?PRID=1539077>)

The FRP of sugarcane payable by sugar factories for each sugar season from 2009-10 to 2017-18 is tabulated below:-

Sugar Season	SMP (Per quintal)	Basic Recovery Level
2009-2010	129.84	9.50%
2010-2011	139.12	9.50%
2011-2012	145.00	9.50%
2012-2013	170.00	9.50%
2014-2015	210.00	9.50%
2015-2016	220.00	9.50%
2016-2017	230.00	9.50%
2017-2018	230.00	9.50%

The year 2013-14 was a water-shed for the sugar industry. The Central Government considered the recommendations of the committee headed by Dr. C. Rangarajan on de-regulation of sugar sector and decided to discontinue the system of levy obligations on mills for sugar produced after September, 2012 and abolished the regulated release mechanism on open market sale of sugar. The de-regulation of the sugar sector was undertaken to improve the financial health of sugar mills, enhance cash flows, reduce inventory costs and also result in timely payments of cane price to sugarcane farmers. The recommendations of the Committee relating to Cane Area Reservation, Minimum Distance Criteria and adoption of the Cane Price Formula have been left to State Governments for adoption and implementation, as considered appropriate by them.

(Source: <https://dfpd.gov.in/sugar.htm>)

## Government Initiatives

Sugar was distributed through the Targeted Public Distribution System (TPDS) by the States / Union Territories (UTs) at subsidized prices for which the Central Government was reimbursing @ ₹ 18.50 per kg of sugar distributed by the participating State Governments /UT Administrations. The scheme was covering all Below Poverty Line population of the country as per 2001 census and all the population of the North Eastern States / special category/ hilly states and Island territories. The National Food Security Act, 2013 (NFSA) is now being universally implemented by all 36 States/UTs. Under the NFSA, there is no identified category of BPL; however, the Antyodaya Anna Yojana (AAY) beneficiaries are clearly identified. The Government of India has reviewed the Sugar Subsidy Scheme and has decided that it is imperative to give access to consumption of sugar as a source of energy in diet, for the poorest of the poor section of the society i.e. AAY families. Accordingly, CCEA in its meeting held on 3.5.2017 has decided that the existing system of sugar distribution through PDS may be continued as per the following:-

(i) The existing scheme of supply of subsidized sugar through PDS may be continued for restricted coverage of AAY families only. They will be provided 1 kg of sugar per family per month.

(ii) The current level of subsidy at ₹ 18.50 per kg provided by the Central Government to States/UTs for distribution of sugar through PDS may be continued for the AAY population. The States/UTs may continue to pass on any additional expenditure on account of transportation, handling and dealers' commission etc. over and above the retail issue price of ₹ 13.50 per kg to the beneficiary or bear it themselves.

(Source: [https://dfpd.gov.in/aay\\_C.htm](https://dfpd.gov.in/aay_C.htm))

### Sugar Prices and Government Measures

- Domestic ex-mill realisations bottomed out decisively during Aug-Sep'15 (INR 27-28/kg in UP) and rose to levels of INR 37-38/kg (+c.36-38% YoY) and remained firm over Feb-May'17 on account of the severe impact of the drought on sugar production and – consequently – tightness in inventories for SS17. However, prices declined and touched INR 27/kg levels in May'18 on account of a) the early start of the crushing season in UP and Maharashtra, b) a significant surplus in SS18 and c) fear of a significant increase in SS19.
- We expect prices to remain stable in the near term given the government's MSP measures (slated to continue until Sep'19) and focus on controlled inflation (various actions such as stock limits, MIEQ, higher blending of ethanol, etc.).
- The global sugar market, which saw turnaround in SS17 (on expectations of a global deficit – hit highs of USD 0.23-0.24/lbs in Nov'16), remained weak on higher production across the globe in SS18 (led by Brazil, India, South America and EU), hitting lows of USD 0.12-0.13/lbs in Jun'17 for a brief period). Prices stabilised and remained rangebound at USD 0.14-0.15/lb. However, in recent months, it has drifted downwards to USD 0.12 0.13/lbs on the anticipation of another global surplus in SS19, led by India.

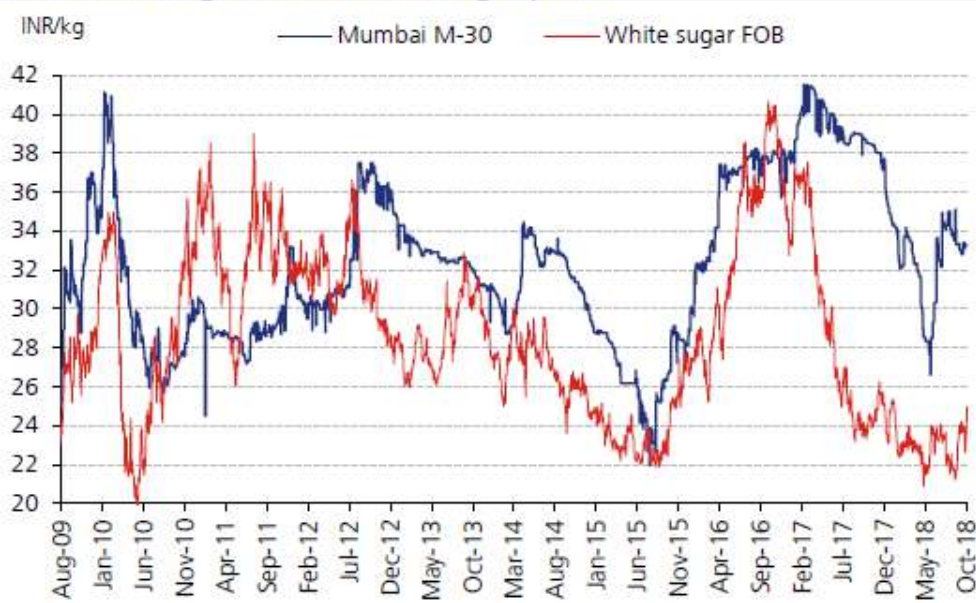

**Exhibit 31. Long-term domestic sugar prices**

(Source: Sector Update – India Sugar; A New Saviour for The Sugar Industry?; JM Financial; October 2018)

## POWER SECTOR IN INDIA

Power is one of the most critical components of infrastructure crucial for the economic growth and welfare of nations. The existence and development of adequate infrastructure is essential for sustained growth of the Indian economy.

India's power sector is one of the most diversified in the world. Sources of power generation range from conventional sources such as coal, lignite, natural gas, oil, hydro and nuclear power to viable non-conventional sources such as wind, solar, and agricultural and domestic waste. Electricity demand in the country has increased rapidly and is expected to rise further in the years to come. In order to meet the increasing demand for electricity in the country, massive addition to the installed generating capacity is required.

In May 2018, India ranked 4th in the Asia Pacific region out of 25 nations on an index that measures their overall power.

India ranks third among 40 countries in EY's Renewable Energy Country Attractiveness Index, on back of strong focus by the government on promoting renewable energy and implementation of projects in a time bound manner.

India has moved up 73 spots to rank 26th in the World Bank's list of electricity accessibility in 2017, according to Mr Piyush Goyal, Minister of State (Independent Charge) for Power, Coal, Renewable Energy and Mines, Government of India.

In September 2017, the Government of India launched the Saubhagya scheme to provide electricity connections to over 40 million families in rural and urban areas by December 2018 at a cost of US\$ 2.5 billion.

(Source: <https://www.ibef.org/industry/power-sector-india.aspx>)

## Bagasse Co-generation Industry In India

When sugarcane is squeezed for its juice, a fibrous pulp material is left over. This material is processed into a usable form called 'bagasse'. For each 10 tonnes of sugarcane crushed, nearly 3 tonnes of wet bagasse is produced. Bagasse is typically used to produce heat and electricity in sugar mills (this is known as cogeneration), but can also be used for a variety of other purposes such as to make paper, cattle feed and even disposable food containers. It helps sugar mills to meet 100% of their energy needs. This is important, as sugar milling is highly energy intensive. Furthermore, sugar milling seasons often coincide with peak demand loads, so sugar mills can benefit immensely from the opportunity to sell surplus electricity to the grid at peak power rates. The facilities needed to generate heat and electricity from bagasse are often located at or near the sugar mill. Generating heat and electricity at the point of energy demand removes the need for costly transportation of the bagasse; involves minimal transmission and distribution costs; and



reduces network losses and augmentation. Energy from bagasse generates less greenhouse gas emissions than conventional fossil-fuel generation.

Sugar industry has been traditionally practicing cogeneration by using bagasse as a fuel. With the advancement in the technology for generation and utilization of steam at high temperature and pressure, sugar industry can produce electricity and steam for their own requirements. It can also produce significant surplus electricity for sale to the grid using same quantity of bagasse. For example, if steam generation temperature/pressure is raised from 400°C to 485°C, more than 80 KWh of additional electricity can be produced for each ton of cane crushed. The sale of surplus power generated through optimum cogeneration would help a sugar mill to improve its viability, apart from adding to the power generation capacity of the country.

The Ministry has been implementing biomass power / co-generation programme since mid nineties. A total of approximately 500 biomass power and cogeneration projects aggregating to 4760 MW capacity have been installed in the country for feeding power to the grid. In addition, around 30 biomass power projects aggregating to about 350 MW are under various stages of implementation. Around 70 Cogeneration projects are under implementation with surplus capacity aggregating to 800 MW. States which have taken leadership position in implementation of bagasse cogeneration projects are Andhra Pradesh, Tamil Nadu, Karnataka, Maharashtra and Uttar Pradesh.

(Source: <http://mnre.gov.in/schemes/grid-connected/biomass-powercogen/>)

Table 1.3 :Source-wise and State-wise Estimated Potential of Renewable Power in India as on 31.03.2017								
States/ UTs	Wind Power	Small Hydro Power	Biomass Power	Cogeneration -bagasse	Waste to Energy	Solar Energy	(in MW)	
	@ 100 m						Total	
							Reserves (E)	Distribution (%)
Andhra Pradesh	44229	409	738	250	123	3840	49590	5.05
Arunachal Pradesh	-	2065	9	-	-	8650	10724	1.09
Assam	-	202	279	-	8	13760	14249	1.45
Bihar	-	527	646	200	73	11200	12646	1.29
Chhattisgarh	77	1098	246	10	24	0	1445	0.15
Goa	1	5	26	-	-	88	120	0.01
Gujarat	84431	202	1226	50	112	35770	121791	12.39
Haryana	-	107	1375	100	24	4560	6167	0.63
Himachal Pradesh	-	3460	142	-	2	33840	37444	3.81
Jammu Kashmir	-	1707	43	-	-	111050	112800	11.48
Jharkhand	-	228	107	-	10	18180	18525	1.88
Karnataka	55857	3726	1222	1400	-	24700	86906	8.84
Kerala	1700	647	864	-	36	6110	9358	0.95
Madhya Pradesh	10484	820	1386	-	78	61660	74429	7.57
Maharashtra	45394	786	1970	2200	287	64	50701	5.16
Manipur	-	100	15	-	2	10630	10747	1.09
Meghalaya	-	230	11	-	2	5860	6103	0.62
Mizoram	-	169	1	-	2	9090	9262	0.94
Nagaland	-	182	10	-	-	7290	7482	0.76
Odisha	3093	286	433	-	22	25780	29614	3.01
Punjab	-	578	3178	160	45	2810	6771	0.69
Rajasthan	18770	52	1122	10	62	142310	162326	16.52
Sikkim	-	267	2	-	-	4940	5209	0.53
Tamil Nadu	33800	604	1164	700	151	17670	54089	5.50
Telangana	4244	102	-	100	2	20410	24858	2.53
Tripura	-	47	3	-	176	2080	2306	0.23
Uttar Pradesh	-	461	1765	2000	5	22830	27061	2.75
Uttarakhand	-	1664	88	80	148	16800	18781	1.91
West Bengal	2	392	529	-	-	6260	7183	0.73

Andaman Nicobar	8	7	-	-	6	-	21	0.00
Chandigarh	-	-	-	-	-	-	0	0.00
Dadar & Nagar Haveli	-	-	-	-	-	-	-	0.00
Daman & Diu	-	-	-	-	131	-	131	0.01
Delhi	-	-	-	-	-	2050	2050	0.21
Lakshadweep	8	-	-	-	3	-	11	0.00
Puducherry	153	-	-	-	1022	-	1175	0.12
Others*	-	-	-	-	-	790	790	0.08
<b>All India Total</b>	<b>302251</b>	<b>21134</b>	<b>18601</b>	<b>7260</b>	<b>2554</b>	<b>649342</b>	<b>982862</b>	<b>100.00</b>
<b>Distribution (%)</b>	<b>30.75</b>	<b>2</b>	<b>1.89</b>	<b>0.74</b>	<b>0.26</b>	<b>66.07</b>	<b>100.00</b>	
* Industrial waste								

Source: Ministry of New and Renewable Energy

(Source: [http://mospi.nic.in/sites/default/files/publication\\_reports/Energy\\_Statistics\\_2018.pdf](http://mospi.nic.in/sites/default/files/publication_reports/Energy_Statistics_2018.pdf))

### Thermal Power Industry In India

As on April 01, 2014, the total coal reserves in India stood at 301.564 billion tonnes, out of which 125.909 billion tonnes were proven reserves. The Government of India has set a generation capacity addition target of 88.5 GW during the period 2012-2017. Against this, generation capacity addition of 101.64 GW is likely to be achieved during said period of 2012-2017. The generation capacity addition during 2017-2022 is being worked out considering the likely generation capacity addition of 101.64 GW during 2012-2017.

The revised tariff policy 2016 ensures adequate return on investment to companies engaged in power generation, transmission and distribution and ensures financial viability of the sector in order to attract investments by companies. Government of India through Ministry of Power launched the initiative of Ultra Mega Power Projects (UMPPs) i.e. 4,000 MW super thermal power projects (both pit head and imported coal based) in November 2005 with the objective to develop large capacity power projects in India. Power Finance Corporation Ltd (PFC) has been appointed as the Nodal Agency to facilitate the development of these projects. Various inputs for the UMPPs are tied up by the Special Purpose Vehicle (SPV) with assistance of Ministry of Power & Central Electricity Authority (CEA). CEA is involved in selection of sites for these UMPPs.

(Source: <http://www.makeinindia.com/sector/thermal-power>)

Total Installed Capacity (as on October 31, 2018)

Fuel	MW	% of total
<b>Total Thermal</b>	2,21,768	64.1%
- Coal	1,95,993	56.6%
- Gas	24,937	7.2%
- Oil	838	0.2%
<b>Hydro</b>	45,487	13.1%
<b>Nuclear</b>	6,780	2.0%
<b>RES (MNRE)*</b>	72,013	20.8%
<b>TOTAL</b>	<b>346,048</b>	

\* Installed Capacity in respect of RES (MNRE) as on 30.09.2017

(Source: <http://powermin.nic.in/en/content/power-sector-glance-all-india>)

The annual growth in power generation during recent years is as under:

Year	Growth in Conventional Generation (%)	Growth in Renewable Generation (%)	Growth in Total Generation (%)
2014-15	8.43	-	-
2015-16	5.64	6.47	5.69
2016-17	4.72	23.97	5.80
2017-18	3.98	24.88	5.21

2018-19 (Upto October 2018)	4.91	29.58	6.91
-----------------------------	------	-------	------

(Source: <http://powermin.nic.in/en/content/overview>)

### SUGARCANE BASED DISTILLERY / ETHANOL INDUSTRY

In India, alcohol is currently produced from molasses. Alcohol is used as a raw material for industrial uses, for production of potable alcohol and as fuel ethanol. Fuel ethanol can be used as a substitute for gasoline. The realization from fuel ethanol is dependent on the government mandated price, which is paid by the oil marketing companies. In addition to this, fuel ethanol has the potential to generate revenues through carbon credits, as is the case with bio-diesel.

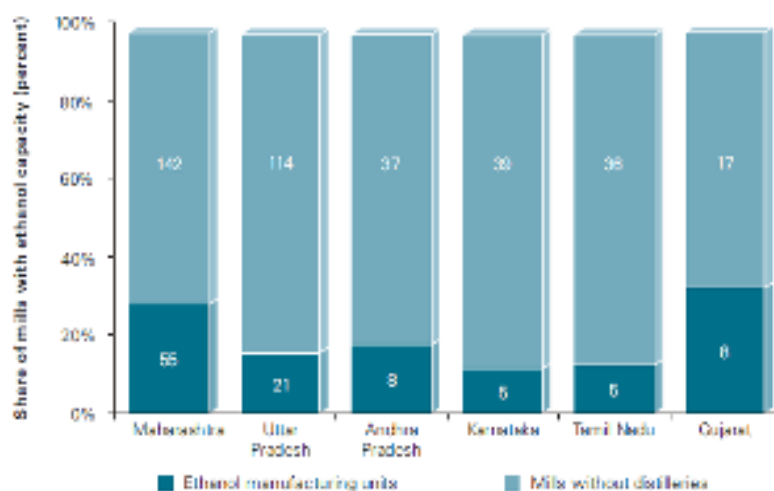

Figure 32: Ethanol producing units (2005)

Source: ISMA Handbook of sugar statistics, Sep. 2008

The Ethanol manufacturing capacity in India as on 2015-16 based on a research by the Indian Sugar Mills Association is as below:

Sl. No.	States	Distilleries attached with sugar mills in						Stand alone distilleries			Total		
		Private Sector			Cooperative Sector			No.	KLPD	KLPA	No.	KLPD	KLPA
		No.	KLPD	KLPA	No.	KLPD	KLPA						
1	Andhra Pradesh	8	290	78300				2	185	59850	10	475	138150
2	Bihar	5	260	70200				1	75	20250	6	335	90450
3	Gujarat				8	220	59400	2	120	32400	10	340	91800
4	Haryana				1	45	12150				1	45	12150
5	Karnataka	14	1100	258600	2	60	16200	1	65	19500	17	1225	294300
6	Maharashtra	18	920	248400	33	1127	304290	21	1150	266340	72	3197	819030
7	Punjab	1	60	16200							1	60	16200
8	Sikkim							1	60	18000	1	60	18000
9	Tamil Nadu	6	260	70200	2	60	16200				8	320	86400
10	Telangana	2	105	28350							2	105	28350
11	Uttar Pradesh	25	2078	544860	4	90	24300	8	392	105510	37	2560	674670
12	Uttarakhand	1	30	8100							1	30	8100
	<b>Total - all India</b>	<b>80</b>	<b>5103</b>	<b>1323210</b>	<b>50</b>	<b>1602</b>	<b>432540</b>	<b>36</b>	<b>2047</b>	<b>521850</b>	<b>166</b>	<b>8752</b>	<b>2277600</b>

(Source: <http://www.indiansugar.com/Ethanol.aspx>)

## INDIAN MADE FOREIGN LIQUOR (IMFL)

India is the third largest global spirits market by volume in the world, just behind China and Russia. In some states, certain alcoholic beverages like wine and beer can be sold in supermarkets that further increase the availability. The Indian alcohol industry is a high-risk industry, on account of the high taxes and innumerable regulations governing it. The Indian liquor industry comprises the Indian Made Foreign Liquor (IMFL), country liquor, foreign Liquor Bottled in Origin (BIO), illicit alcohol, beer and wine segments. The overall IML market is increasing at the rate of 9 to 10 per cent annually. Country liquor produced in local licensed distilleries and is made of cheap raw material, primarily rectified spirits of grains or molasses.

An Alcoholic beverage is a drink containing ethyl alcohol of agricultural origin in any percentage, derived either through natural fermentation, or addition during process. Ethanol or ethyl alcohol is produced through a natural process when the yeast converts the sugar contained in fruit, cereals and sugarcanes, into alcohol. Pure alcohol is a colourless, pure liquid. The process used for its preparation is called fermentation. The Indian liquor market is concentrated in the southern part of the country, with the region accounting for about 60% of total IML sales and 45% of total beer sales. Andhra Pradesh is the largest consumer of both while Karnataka and Maharashtra are the second-largest consumers of IML and beer respectively.

(Source: <http://epaper.livemint.com/epaper/viewer.aspx> dated 25th November 2017)

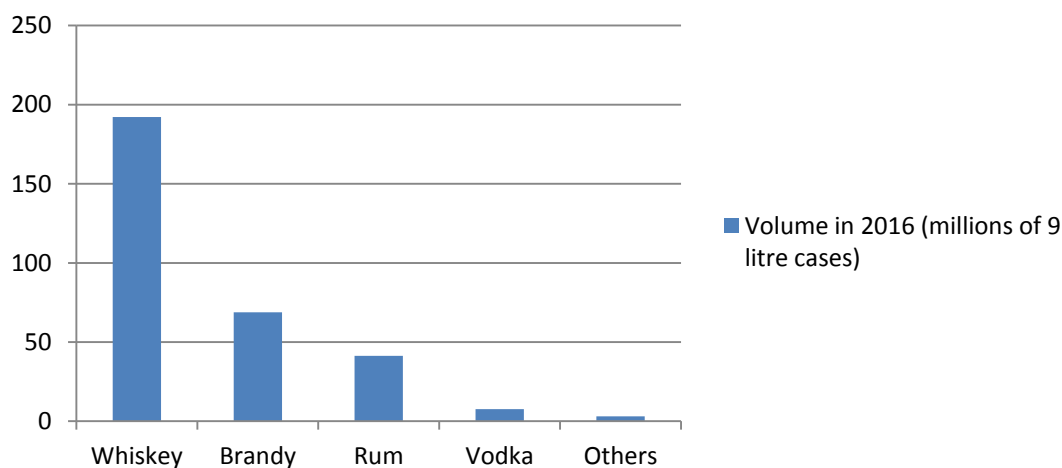

(Source: <http://epaper.livemint.com/epaper/viewer.aspx> dated 25th November 2017)

Flavour wise segmentation of IMFL

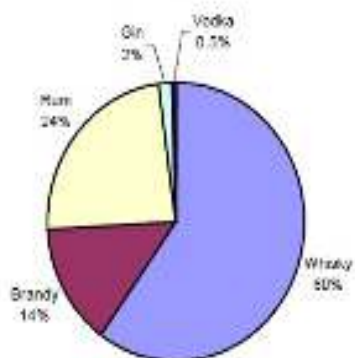

Key IMFL Consuming States

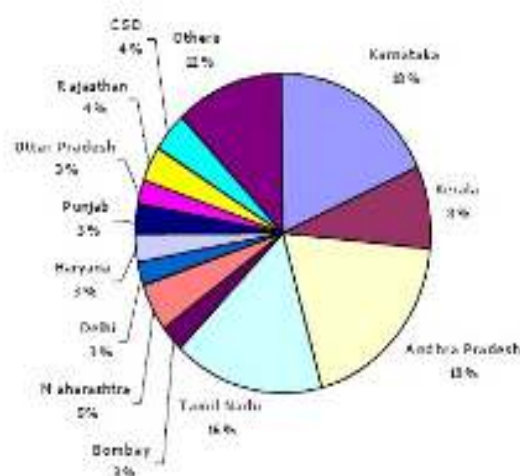

(Source: <https://slidedocument.org/liquor-industry-crisil>)

Government regulation at every level have affected the Indian liquor Industry, introducing structural rigidities. Apart from high level of taxes and levies (that account upto 65% of the consumer price), regulations pertaining to liscencing, creation or expansion of brewing/distilling and bottling capacities, manufacturing processes (grain based or molasses based), distribution and advertising impinge on the industry. Further, liquor being a state subject, every state has different regualtions (including those on distribution) and tax rates for the industry apart from restrictions as well as levies on the inter-state movement of liquor. A global study by Paris-based Organization for Economic Cooperation and Development (OECD) has found that alcohol consumption in India has risen by 55% over a period of 20 years, from 1992 to 2012. The forecast is that 2017-18 will be challenging for most liquor majors as the highway ban continues. The implementation of the Goods & Services Tax is also set to disrupt the trade.

The key raw material for IML players is molasses, which is by-product of sugar. Molasses is processed and distilled to produce refined spirit (ethanol). Players with primary distillation facilities directly consume molasses while others purchase ethanol. Supply of molasses primarily depends on sugarcane production levels, which show cyclicity since sugarcane itself is a cash crop with its production showing cyclicity. This cyclicity also imparts a commodity nature to molasses. As molasses demand arises only from ethanol demand, the demand-supply scenario for ethanol determines the raw material price for IML players. Ethanol is consumed by the liquor industry and to produce industrial alcohol, each segment accounting for roughly half the ethanol consumption.

Ethanol consumption is expected to rise in the future when the commercial blending of ethanol with petrol (for producing gasohol) takes off. In the long term, however, the supply is also expected to increase as more sugar manufacturers are expected to set up primary distilling facilities and as new sugar mills are expected to come up in the form of integrated plants with cogeneration and distillation facilities. Thus, while molasses / spirit prices are likely to increase after the commercial production of gasohol starts, they are likely to come down from increased level in the long term.

## **VINEGAR INDUSTRY IN INDIA**

Vinegar has been used across the world for over thousands of years. Driven by its multifunctional properties, vinegar is increasingly popular with consumers as new blends, applications, and specialty products continue to enter the market. Being a source of vitamin B-1, riboflavin as well as mineral salts, it is gaining popularity among the consumers for its numerous applications. Emerging as a functional food, it is primarily used as flavouring and preserving agent. Although, vinegar is majorly consumed in the food and beverage industry, it also finds applications in the healthcare industry, cleaning industry and agriculture industry. According to IMARC group, the global vinegar market has reached values worth around US\$ 1.26 billion in 2017 growing at a CAGR of 2.1% during 2010-2017.

(Source: <https://www.reportbuyer.com/product/4715194/vinegar-market-global-industry-trends-share-size-growth-opportunity-and-forecast-2017-2022.html>)

## OUR BUSINESS

*This chapter should be read in conjunction with, and is qualified in its entirety by, the more detailed information about our Company and its financial statements, including the notes thereto, in the sections titled 'Risk Factors' and 'Financial Information' and the chapter titled 'Management Discussion and Analysis of Financial Condition and Results of Operations' beginning on page nos. 17, 202 and 252 respectively, of this Red Herring Prospectus.*

*Unless otherwise indicated, the financial information included herein is based on our Restated Consolidated Financial Statements for Financial Year 2015, 2016, 2017, 2018 and 2019 included in this Red Herring Prospectus. For further information, see "Financial Statements" on page no. 202 of this Red Herring Prospectus.*

*Unless the context otherwise requires, in this section, reference to "we", "us", "our", "Company" or "Our Company" refers to Vishwaraj Sugar Industries Limited.*

### OVERVIEW

We are an integrated sugar and other allied products manufacturing company operating from Belgaum District in the State of Karnataka which is designated as one of the "High Recovery zones" for sugar production by Government of India. We operate a single location sugar unit having licensed crushing capacity of 11,000 TCD. In addition to sugar we also manufacture other allied products like Rectified Spirits, Extra-Neutral Spirits, Indian Made Liquor, Vinegar, Compost, Carbon dioxide (CO<sub>2</sub>), etc. and are further engaged in the generation of Power for captive consumption as well as external sale. Our business can hence be broken up into five main segments namely Sugar, Co-Generation, Distillery, Indian Made Liquor (IML) and Vinegar.

In the year 2001, we commenced operations of manufacture of Distillery products such as Ethanol, Rectified Spirit and Extra Neutral Spirit. In the year 2006, our Company implemented backward integration and began commercial operations for Sugar manufacture from sugarcane, along with Co-Generation capabilities. During the year 2008, we began bottling of Indian Made Liquor. Currently our integrated unit processes sugarcane to produce sugar and the by-products are used to generate electricity for captive use and commercial sale, manufacture rectified spirit, ENA, IML, Vinegar, Press-mud and Compost. Over the years, we have expanded the production / manufacturing capacities of all our products. Our present licensed manufacturing capacity for our various products is given below:

Sr. No.	Product	Current Approved Capacity
1.	Sugar	2,42,000 Tons / Year <sup>(1)</sup>
2.	Bagasse	6,60,000 Tons / Year <sup>(1)</sup>
3.	Molasses	88,000 Tons / Year <sup>(1)</sup>
4.	Rectified Spirit	30,000 KL / Year
5.	Extra Neutral Alcohol (ENA)	21,000 KL / Year
6.	Industrial Ethanol	90,000 KL / Year
7.	Electricity / Power	4,96,800 MW / Hr
8.	Brewed Vinegar	10,350 KL / Year

<sup>(1)</sup> The above licensed capacities are equivalent to a total Sugarcane crushing capacity of 11,000 TCD working for approximately 200 days per year (Crushing Season) at an average 11% recovery rate for sugar, 30% for Bagasse and 4% for Molasses.

Production of sugar, power and distillery products requires our Company to adopt stringent Quality Assurance and Quality Control standards (QA/QC). We have set-up indigenous laboratories for each department which ensures that quality of raw material used in the production process and also the finished goods delivered to our customers is subject to various tests. To access and facilitate compliance with applicable requirements, we regularly review our quality systems to determine their effectiveness and identify areas for improvement. This helps in improving our procurement process thus reducing wastages, returns and other related costs.

During the production of sugar; bagasse and molasses are produced which are the basic raw materials for power generation and Distillery (Spirit) manufacturing unit, respectively. The sugar unit of our integrated production facility first crushes sugarcane to extract juice and processes the juice to produce sugar. The sugar manufactured is then graded and packed based on the size of crystals and quality of the sugarcane. During the last fiscal year we produced 98,415 tonnes of sugar. After extracting the juice from sugarcane, the residual fibre leftover called Bagasse is used as a fuel for power generation. The molasses used in the process of sugar production is fermented and distilled to manufacture various spirits (Rectified Spirit and Extra Neutral Spirit) and IML in the distillery unit of our integrated production and manufacturing facility.



Bagasse is the fibrous residual matter used as a bio-fuel to generate steam in high pressure boilers for turning turbines to generate electricity. We obtain enough Bagasse during the crushing seasons, such that the electricity produced is used not just for captive consumption, but also for sale. For electricity generated over and above our captive consumption, we have entered into Power Purchase Agreements with 5 electricity distribution companies in Karnataka to supply a total of 22.4 MW. It is possible that during the year we may produce surplus energy and supply the surplus energy to other Companies / Industries based on demand.

Molasses is the viscous product resultant of refining sugarcane juice. Molasses, which forms the primary raw material for the distillery unit, is fermented, distilled and made to undergo various processes for making rectified spirit and extra neutral spirit. Rectified Spirit is processed to manufacture Industrial Vinegar. Extra- Neutral spirit is further processed for manufacture of IML products. The Extra-Neutral spirit is blended to manufacture Whiskey which is sold by us under our various brands like VSL Deluxe Whisky, District-1 and VSL Black. During the last financial year, we manufactured approximately 1,23,060 boxes of IML, 10,779 KL of Industrial Vinegar, 3,156.59 KL of Rectified Spirit and 969.47 KL of Extra-Neutral Spirit.

Further the waste water extracted from Distillery unit is called as spentwash which is further mixed with mud to form Compost / Organic Manure, which is supplied back to farmers for cultivation of their fields which ensures higher yields. Further the company has set up a CO<sub>2</sub> plant also. Thus, we believe that nothing is wasted, as every single output whether residue or by-product is utilised.

The Revenue Model of the Company for March 31, 2019 is as below:

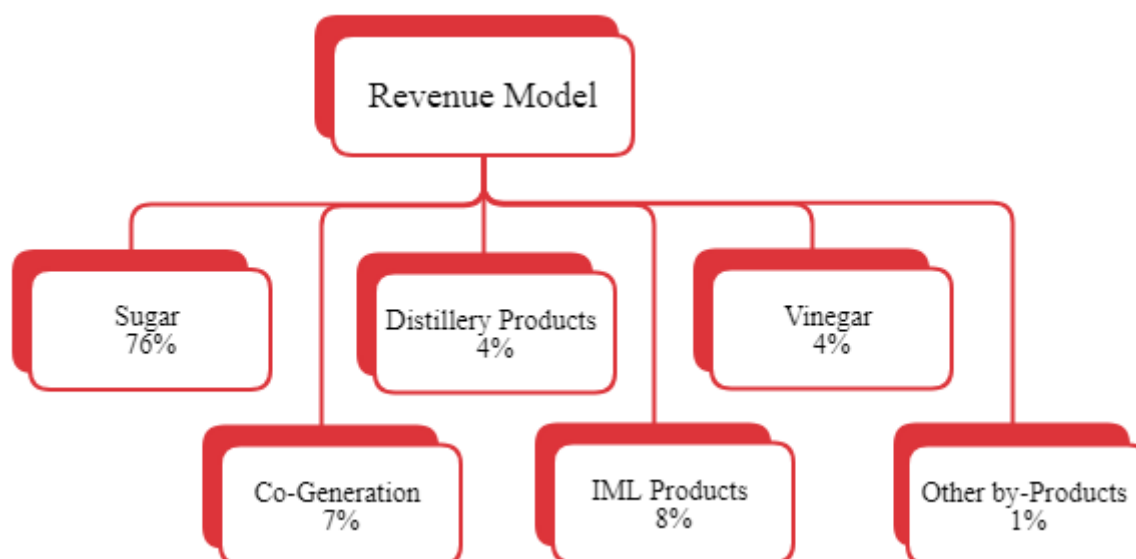

For details of the segment-wise revenue details, please refer the “Annexure VI – Note 35 – Segment Reporting” on page no. 240 of the Red Herring Prospectus.

Our income from the sugar business formed approximately 76%, 66% and 67% of our total net sales in the F. Y. 2019, F. Y. 2018 and F. Y. 2017, respectively; Income from the co-generation business formed 7%, 6% and 5% of our total sales in the F. Y. 2019, F. Y. 2018 and F. Y. 2017, respectively; Income from the Distillery business formed 4%, 3% and 11% of our total sales in the F. Y. 2019, F. Y. 2018 and F. Y. 2017, respectively; whereas, Income from the IML business formed 8%, 18% and 15% of our total sales in the F. Y. 2019, F. Y. 2018 and F. Y. 2017, respectively.

Our revenue from operations for the last 3 years i.e. F. Y. 2016-17, 2017-18 and 2018-19 were ₹ 32,184.21 lakhs, ₹ 25,928.30 lakhs and ₹ 30,679.58 lakhs. Our Company reported losses in 2 of the 3 above periods, mainly due to high sugarcane price and competitive sugar prices. Our net profits / loss for F. Y. 2016-17, 2017-18 and 2018-19 were ₹ 606.25 lakhs, ₹ (426.67) lakhs and further ₹ (1,761.99) lakhs respectively.

As on May 31, 2019, our Company had 950 employees.

## OUR COMPETITIVE STRENGTHS

### Experienced Promoters and strong Executive Team

Our Promoters are engaged in the business of distillery and sugar production from sugarcane for more than a decade and have thus established a proven background and rich experience in the sugar and derived product industry. In the year 2001, our Promoters were part of the commencing business of a small distillery unit in Bellad, near Belgaum, Karnataka with a capacity of 35 KLPD. With their business acumen and foresight, our Promoters, in the year 2006, undertook backward integration and started the sugar production unit and also a co-generation unit with a capacity of 2500 TCD and 14 MW respectively. With the continued support of the farming community in the area we were able to expand our sugar unit capacity from 2500 TCD to 5500 TCD in the year 2009. This further led to the enhancement in our power generation capacity from 14 MW to 36.4 MW. Today our Company has an integrated manufacturing unit for products ranging from Sugar to electricity generation, rectified spirit, IML, vinegar to compost, thus utilising technically the entire waste from sugar production. For further details of our Promoter's experience and background, please refer the chapter titled "*Our Promoters and Promoter Group*" on page no. 188 of this Red Herring Prospectus.

Also, our Company and our Promoters are aided by a team of experienced personnel. The team comprises of personnel having technical, operational and business development experience. We believe that our management team's experience and their understanding of the sugar production & derived product manufacturing business will enable us to continue to take advantage of both current and future market opportunities. It is also expected that our management personnel's experience will help us in addressing and mitigating various risks inherent in our business, including significant competition, reliance on independent agents, and fluctuations in sugar and sugarcane prices.

Our team includes senior executives and managers, many of whom are having over 15-20 years experience in the engineering and sugar industry. We believe our management and executive team has the long-term vision to provide stability and continuity to our businesses.

### Wide range of products

The process of production of sugar produces various residual materials and by-products like Bagasse and Molasses. These residual materials are used by us as raw materials for manufacturing further products. The Bagasse, which is a dry residue after the sugar production process is used to generate electricity by burning the same in the Boilers. Molasses is used in the distillery unit to make a range of products like rectified spirit, ENA and IML and the rectified spirit so produced is used in the production of Industrial Vinegar. Also surplus Molasses is sold directly to other distillery units. Further, the mud generated in the sugar process is used along with certain distillery unit wastes to produce CO<sub>2</sub>, press mud and compost.

The customers of different products cover a wide range of industrial sectors like FMCG, Government agencies, Food industry and Cold Storage industry to name a few. The above wide range of products gives us a large market for each product. We have made sugar sales to various wholesalers, FMCG companies and also to local and state government agencies. Our distillery products; rectified spirit and ENA are sold to various other standalone distillery units who process it for further industrial use or to make liquor. Though the IML manufactured by us is sold only through KSBCL, our products are supplied to various wholesalers and retailers in the state of Karnataka through KSBCL. The Industrial Vinegar manufactured by us is mainly sold as preservatives and also for certain industrial uses. We have entered into a PPA with electricity supply companies for sale of our surplus power so generated. Further, other by-product like CO<sub>2</sub> is sold as a gas and liquefied CO<sub>2</sub> which has different applications in several industries from medicine, food storage, electronics and agriculture. Once the sugar production is started, we are in a position to always provide raw materials to the other products in sufficient quantities for captive consumption and also for external sale. For further details, regarding our product portfolio, please refer "*Our Business – Our Products*" on page no. 136 of this Red Herring Prospectus.

### Integrated operations and economies of scale

We have integrated operations enabling us to meet the time, cost efficiency, quality and quantity requirements. The residual material and by-products generated from the production process of one product is used as a raw material for manufacturing another product. Thus our diversified but integrated business model provides most of the necessary raw materials in-house for the various business segment products leading to reduced costs and control over the input material. Our unit has been setup such that the residual materials from one production process are transported to their respective product units either via pipes or conveyor belts or other in-house transport mechanism. This provides us seamless flow of raw material for all our products and also enables us to transport the surplus materials, if, any, for

direct sale. This integration allows us not only to save enormous costs and have less dependence on third party for input materials, but also helps us achieve economies of scale by controlling the inputs / production based on each previous process, improving our efficiency and margins.

The main raw material for production of our various segments is sugarcane and our integrated unit processes each component of the sugarcane to manufacture a variety of products relating to the food and beverage industry. Further, with approximately 49 villages from whom we procure our sugarcane produce uninterruptedly till date, we are also able to achieve economies of scale by bulk buying from the farmers.

### **Strong Technological Capabilities**

Our integrated manufacturing unit situated at Bellad-Bagewadi has been installed with various latest machinery and technology. We have installed The Distributed Control System (DCS) at our sugarcane milling and co-generation facilities for precision system management. The DCS is a type of automated control system that is distributed throughout a machine to provide instructions to different parts of the machine. Instead of having a centrally located device controlling all machines each section of a machine has its own computer that controls the operation. DCS is commonly used in manufacturing equipment and utilises input and output protocols to control the machine. The entire system of controllers is connected by networks for communication and monitoring. The successful installation of the DCS which enables us to achieve reduced cost, reduced environmental effect, higher efficiency and reduced response time, reliability of equipment, ease of maintenance and conservation of energy.

We have also installed the latest machineries for our Distillery and Vinegar units. In the financial year 2016-17, we installed a Tetra Packaging machine for our IML products which not only saves our considerable bottling cost but also helps us in our endeavour to protect the environment by reducing glass / plastic bottles being discarded after use. The machinery used for manufacture of Vinegar has been imported from China and we use the latest technology for processing the diluted ethanol into Vinegar.

### **Strategic location of our manufacturing unit**

Sugarcane is the principal raw material used for the production of sugar. Our business depends on the availability of sugarcane and any shortage of sugarcane may adversely affect our results of operations. After de-regulation of the sugar industry, there are no restrictions on the farmers to sell their produce to any particular sugar unit. However, due to our continued relations with the farmers, are regular and advance payments, assistance with high quality seeds and timely aid in harvesting and transportation of the cane, we have ensured continuous supply of sugarcane from a large number of farmers in the nearby villages in our vicinity and other areas. As per the earlier cane area allotted order to our Company by the Sugarcane Commissioner, Bangalore, there were 28 villages in Taluka Hukkeri, 12 villages in Taluka Chikkodi and 9 villages in Taluka Gokak in Belgaum District reserved for the supply of sugarcane to our factory.

Over the period of time, there has been a considerable increase in the acreage of sugarcane cultivation in the nearby villages thus increasing the sugarcane growing areas. To tap this increase, in the F. Y. 2015-16 increased our installed capacity from 5,500 TCD to 8,500 TCD. Though, due to poor rainfall the sugarcane production has been affected, in turn impacting our utilisation, we believe that the larger sugarcane area will provide us with ample supply in seasons of good rain. Also, having a large sugarcane supply base ensures that, in times of cane shortage, due to its long standing relationships with farmers, the factory gets a considerable share of the cane available in the vicinity of our factory. Also, a simultaneously large sugarcane crushing capacity also ensures a larger stock of Bagasse for the co-generation of power, as also a substantial increase in the Molasses available for our distillation business.

Besides, our factory unit is located approximately 70 kms from the main city of Belgaum, which has established road and rail connections to various major cities like Bangalore, Chennai, Mumbai, Pune and Goa. The air route from Belgaum is also constantly growing which enables certain urgent transportation possible.

### **Cordial and strong relationships with sugarcane farmers**

We had approximately 49 villages allotted to us under the cane area allotment order by the Sugarcane Commissioner of Bangalore, in the vicinity of our factory unit and have cordial relations with every farmer in the nearby areas. We have maintained good and cordial relations with large sugarcane growing farmer base so as to ensure un-interrupted supply of sugarcane and within the required time period. Besides making timely payments to sugarcane farmers, we provide them with high-quality sugarcane seeds at subsidised rates, thus being an integral part of the cane development process. This not only helps us in ensuring the supply of sugarcane to us but also ensures quality of the sugarcane so that the

recovery from these sugarcane is good. We have entered into agreements for harvesting and transporting of sugarcane produced by the farmers, for no cost to the farmers. The harvesting and transporting groups are paid by our Company and this cane procurement activity ensures the harvested produce is transported to our factory for crushing.

Besides, the raw material procurement, our Company has also established many shops, local hotels and eating places for the convenience of the farmers when they come to our factory unit to sell their produce. These amenities keep the farmers happy and help us build and maintain a good and cordial relationship. Despite the cyclical nature of the sugar industry, we keep strong ties with the desired sugarcane growing farmers. We believe that these relationships are a competitive advantage as farmers have no obligation to sell their produce to us and they are free to sell to any sugar factory. Also, assisting the farmers with seeds, irrigation etc, ensures that the farmers do not switch to other crops that may be more profitable.

### **Captive Power plant and exportable capacity**

Power is an important factor in every manufacturing facility. Considering the integrated nature of our manufacturing unit and its corresponding power requirements, we have installed a power plant with electricity generation capacity of 14 MW and 22.4 MW (from Bagasse / Coal). Our entire electricity requirement during the crushing season is met out of the electricity generated by us in-house. Also, the captive power generation gives us stable and uninterrupted power supply which is very crucial in manufacturing of our products. It further gives us steady and quality supply of steam for our various processes in the sugar, co-generation and distillery units. Uninterrupted power supply helps to avoid any delays in manufacturing process thereby ensuring optimum utilization of our capacities and reducing external electricity costs, especially during the crushing season.

With a total co-generation capacity of 36.4 MW, we ideally use approximately 14 MW for our captive consumption. The remaining electricity generated is sold to third parties through a PPA or an open sale. Currently, we have entered into a PPA for sale of balance MW electricity with 5 different electricity supply companies.

Further, we have installed various energy saving devices at our production facilities such as planetary gear boxes, variable frequency drives, swing type fibrizor, high efficiency pumps and energy efficient motors which help us reducing the consumption of energy in our crushing operations. We have also installed planetary gear boxes in our boiling house section and have further introduced energy efficient condensers and unforced cooling tower as power saving measures. Similarly, in the co-generation unit, our power consumption has been reduced due to installation of a spray pond instead of forced draught cooling tower. Due to the implementation of the above measures we have been able to reduce our captive consumption leading to higher availability of exportable power.

**For risks related to our business, our Company and our industry, see “Risk Factors” on page no. 17 of this Prospectus.**

### **OUR STRATEGIES**

Our strategic objective is to improve and consolidate our position as a sugar manufacturer with a continuous growth philosophy. The diagram below represents our continuous growth philosophy being implemented on a day-to-day basis.

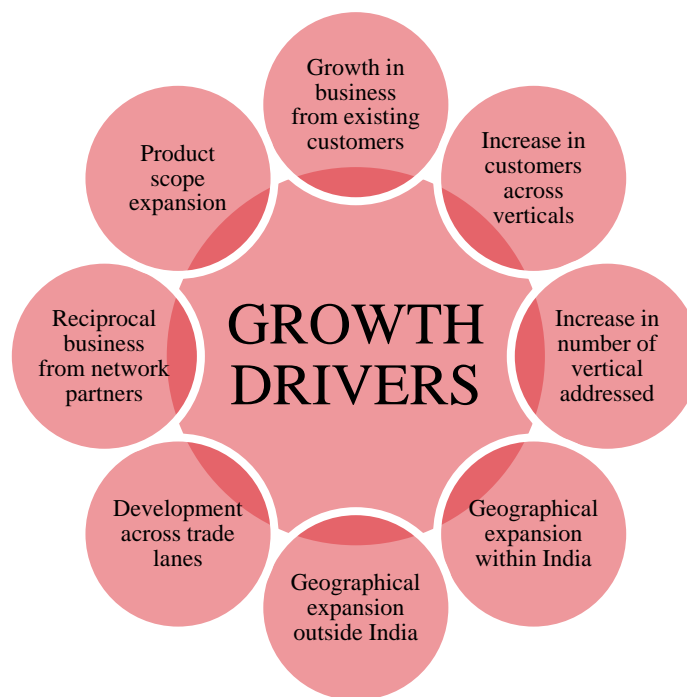

Our continuous growth philosophy is being driven with the strategic levers of operational excellence, strengthening existing services, customer satisfaction, ecosystem development, innovation and marketing.

#### ***Increasing operational efficiency***

Our product portfolio consists of sugar and various other products manufactured by processing its residual products. Hence operational efficiency for each product is related to its previous product's efficiency and quality. We continue to invest in increasing our operational efficiency throughout the organisation. We are addressing the increase in operational output through continuous process improvement, increasing recovery rate through timely sugarcane crushing, technology development throughout the products, consistent quality and customer service. We also strive to achieve alignment of our people towards 'process improvement' through change management and upgrading of skills for latest technology and as required for customer satisfaction is a continuous activity. Awareness of this quality commitment is wide spread among all the employees.

#### ***Explore possibilities of geographical expansion***

Our Company is currently situated in the area of Bellad Bagewadi and our Company intends to propose to explore other geographical locations within the Belgaum District. Our Company, with intent of exploring new location with significant sugarcane cultivation area and abundant sugarcane growth has acquired a land of approximately 9 acres and 12 Gunthas by way of 'Full Paid Power of Attorney'. For details of the land purchased, please see the section "Properties – Our Business" on page no. 151 of this Red Herring Prospectus. However, our Company is still at planning stage and has neither finalised any specific utilisation for the said land nor any plans have been put forth regarding the funding, capacity, products and other details.

#### ***Addition of new IML products***

Our IML products currently consist of only whisky which is mainly sold under our brand "VSL Deluxe Whisky". Besides, we also have whisky brands like "District – 1" and "VSL Black". With the success of our whisky brands, our Company intends to launch other products like Rum, Gin and Vodka under the same brand. Our Company has already obtained the relevant approvals for these products and currently in the testing stage of these products.

Our IML products currently contribute approximately 8% of our total revenue from operations. We believe that the addition of these new products will enable us to cater to a bigger market and also enable us to cater to customers of larger demographic base. Further, different products with the existing brand name will allow us greater brand recognition and also enable us to enter different markets with a large product portfolio.

### ***Augment our fund based capacities in order to scale up business operations***

The sugar industry is characterised by high debtors and advance payments to farmers and harvesting & transportation agents. Our customers, mainly being entities in the food, petroleum, beverages, and also government agencies, we generally offer substantial credit period to them. Further, during the crushing season, we have to make advance payments for various minor raw materials, utilities and other services so as to carry out the un-interrupted crushing. Thus our operations are working capital intensive.

It is hence our strategy to raise funds from this issue and augment our fund based working capital capabilities. We believe that companies with high liquidity on their balance sheet would be able to better negotiate with sugarcane suppliers. With the de-regulation of the sugar industry, farmers are free to sell their produce where they like and are not obligated to sell any portion of the same to us. Better liquidity will also provide us with sufficient incentives to ensure the farmers prefer us for selling their sugarcane produce in each season. Also, we invest a portion of our working capital to provide some of our farmers with high quality seeds for better crop quality. Additional working capital will enable us to offer such high quality seeds on larger quantities and to a large farmer base. Funding this working capital requirement from the proceeds of the Fresh Issue will also enable us to save a considerable interest cost due to lower working capital borrowings. For further details regarding the working capital being raised through this Offer, please refer to section “*Objects of the Offer*” on page no. 102 of the Red Herring Prospectus.

## **DETAILS OF OUR BUSINESS**

### **LOCATION**

We have setup our integrated facility over an area of around 132.85 acres (57,86,946 sq. ft.) which houses our Registered Office, Manufacturing Unit, Packing Unit and Storage Unit. All of these units are located in close proximity to each other within the facility. Our entire premise is located at Bellad Bagewadi, District, Belgaum, Karnataka - 591 305.

For further details of our properties including the above location, please refer to “*Our Business – Properties*” on page no. 151 of this Red Herring Prospectus.

### **OUR PRODUCTS**

Our Company is engaged in the business production of sugar and manufacture of other products including Distillery (Spirits) products, Indian Made Liquor, Vinegar, other by-products and also in the generation of power.

### **SUGAR**

Our Company is involved in the process of production of sugar, with a total capacity crushing capacity of 8,500 tonnes per day. Sugarcane being a seasonal crop, the sugar manufacturing majorly takes place during the sugarcane period of October to April known as Crushing Season. We use modern technology which enables us to optimally utilize the available resources to ensure maximum crushing capacity and thereby maximize the production of sugar. We have a total licensed sugarcane crushing capacity of 11,000 TCD and installed sugarcane crushing capacity of 8,500 TCD.

The sugar produced by us is differentiated on the basis of the size of the sugar crystals. These types are termed as M, M2, S1, S22 and S30 which are in descending order of the size of the crystals.

Since the de-regularization of Sugar, Our Company has developed a robust marketing and sales team which liaisons with various major brands. We sell our manufactured sugar to various wholesalers, stockists and also to several FMCG companies throughout the country, who use sugar for manufacture of various biscuits, confectionery and beverages.

### **Plant & Machineries**

Our Company uses modern technology which enables us to fully utilize the available resources to ensure maximum crushing capacity and thereby maximizes the production of sugar. We have installed latest machinery including a fully automated milling tandem by installation of Distributed Control System (DCS). We have highly automated sugar production facility with plant & machinery ranging from cane loading / unloading cranes, cane cutting machines, mill tandems, different juice heaters, Air Compressors, sulphitation tanks, evaporators, centrifuges, crystallisers, hoppers and automated carriers, elevators and relay belts for transferring products from one process to another. We confirm that our Company has not acquired any second hand machinery for this unit.



## Raw Materials

### *Sugarcane*

Sugarcane is the only and basic raw material for all our product segments. Our Company purchases all our required sugarcane directly from farmers. Currently, we purchase sugarcane from estimated 25,000 - 30,000 farmers who are majorly within and around the area where our manufacturing unit is situated. These Farmers growing sugarcane are based in approximately 49 villages allotted to us around our production facility. We offer sufficient incentives, infrastructure and assistance in various stages of cultivation, thus ensuring loyalty from these farmers. We also appoint contractors who are responsible for harvesting and transporting the sugarcane from the farms to our factory. Further, our Company has and will continue to maintain good relations with the sugarcane farmers in our vicinity which ensures uninterrupted supply of sugarcane to our factory during the crushing season.

### *Sugarcane Cultivation*

We have undertaken several initiatives to improve sugarcane production in our area, and also on improving cane quality and hence recovery, and at the same time developed good relations with the farming community of the area.

Sugarcane development initiatives undertaken by us include conversion of other crop areas to sugarcane cultivation, field-extension activities, providing quality seeds and agri-inputs to the new farmers in the area. Commercial and Co-operative banks have been associated with us in our effort for such activities. Apart from this we have also been associated in helping farmer groups develop irrigation sources like check dams, percolation tanks, individual/group lift irrigation schemes, sump-wells as well as taking up land development to bring additional acreage under cultivation especially the land which is either barren or unsuitable for growing sugarcane in its present state. We have designated areas for cultivation of high quality sugarcane studs which are distributed to various famers as high quality seeds on a subsidised rate.

Our sugar production is based on the grade of sugarcane procured by us. Different grade / types of sugarcane have different recovery rates. Some of the major grades of sugarcane used by us are given below:

Sr. No.	Sugarcane Grade	Description and Quality
1.	COC 671	The Variety CoC671 is sugar rich, early maturing and high sucrose variety. Also very vigorous and quick growing and having good filed keeping quality.
2.	CO 8011	It is mid-late to late maturing variety, sparse/late flowering. Also it is a high fibre variety and good ratooning ability. Low sucrose content variety.
3.	CO 86032	Co 86032 is a medium maturing variety. Grows well in all soil types, has multi – rationing potential, can be grown throughout the year.
4.	CO 94012	This variety has high cane yield. Improved Plant and cane productivity with better juice quality. Moderately tolerant to drought and salinity.
5.	CO 2001-15	It is a mid-late maturing sugarcane variety suitable under normal and drought conditions. The canes are tall and medium thick with light canopy.
6.	CO 740	This is a high yielding variety of sugarcane both in plant and ratoon crops and is suitable for late crushing and adasali planting

Besides the above many other varieties like CO 92005, CO 92020, CO 98012, CO 9805, COM 0265, CO 434, CO 86038, SNK 7680, CO 419, CO 8011, etc. are used by us, depending on the availability.

### **Manufacturing Process**

We obtain sugarcane from various farmers who are within and around the area where our manufacturing unit is situated. Once the sugarcane is received by us, we weigh them to ascertain the quantity of sugarcane received by us so that the farmers can be paid accordingly.

The sugarcane is fed on to the cane feeder through the loader. The sugarcane undergoes cutting, levelling and fiberising through the conveyor belt thereby preparing the cane for the milling process. We have 5 milling tandem one after the other where the cane is crushed and raw juice to the extent of 95% - 98% is extracted from it at each level.

The leftover after extraction of raw juice is called bagasse. This bagasse is used by the boilers as bio-fuel for steam generation. The steam generated is used for the rotation of turbines which in turn generates electricity, which is used for captive consumption and supplied to clients.

The raw juice so extracted passes through the rotary screen where the raw juice is strained for major particles of bagasse and other impurities. A reagent, Phosphoric Acid, is added to the strained juice which clarifies the final impurities in the strained juice. The juice is then transferred to the Boiling containers and is subjected to various degrees of heating. Once it passes through the initial heating process, milk of lime and Sulphuric dioxide is added. The juice is heated in various stages and at varying temperatures ranging from 79° C to 99.5° C.

The output from heating the juice is processed into the juice clarifier and clear juice is extracted by heating the clear juice at a very high temperature of 110° C.

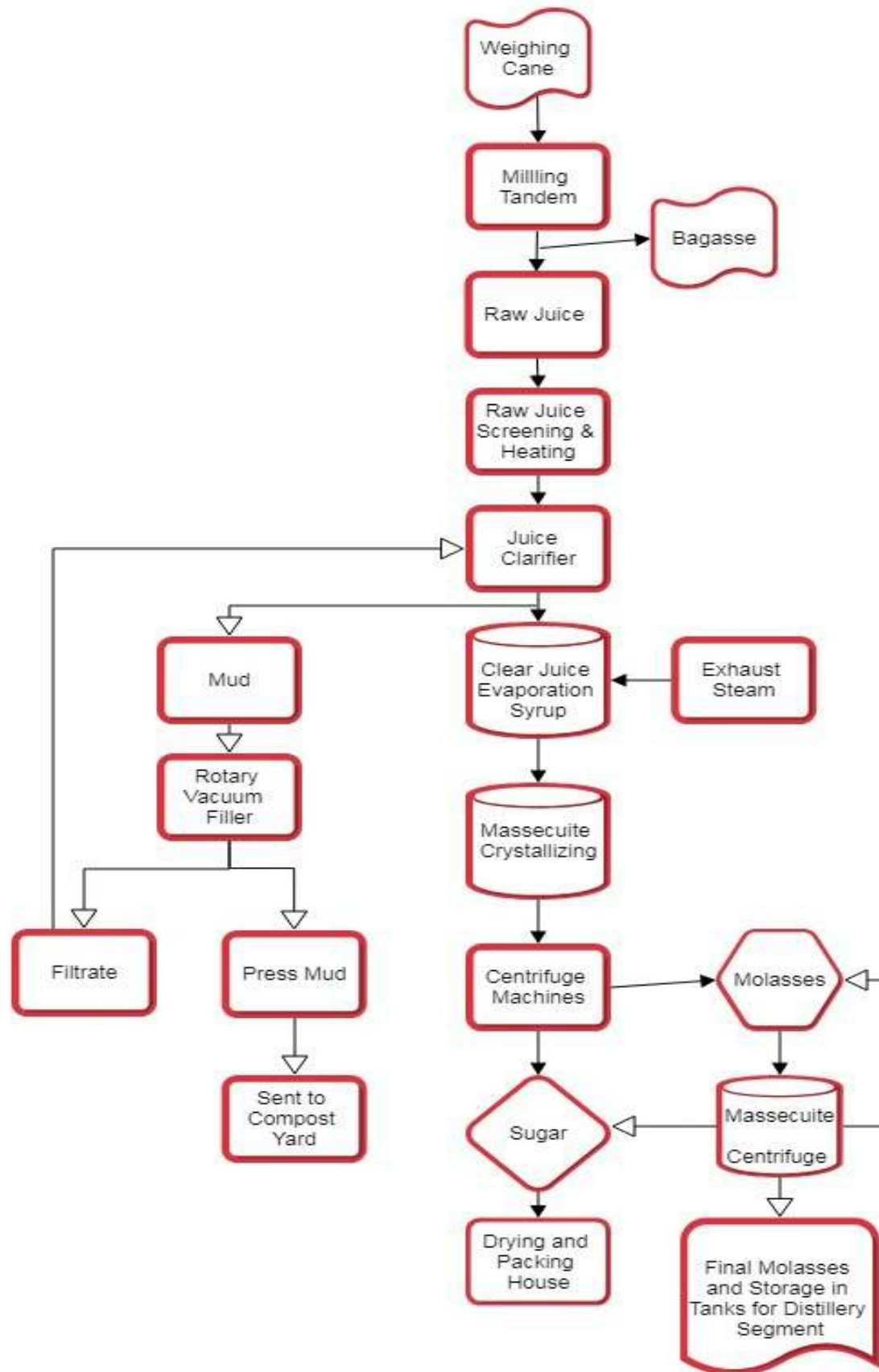

The output from the above process is then inserted in the Multiple Effect Evaporation System which results in Syrup like substance and stored in Syrup supply tanks. The Syrup in the Syrup supply tank is then subjected to the process of Crystallizing and Massecuite in various centrifuge machines giving us sugar crystals.

The viscous product which does not result in sugar is called as Molasses. Molasses is subject to the process of Crystallizing and Masecuite and is further processed in the centrifugal machines for production of sugar. This process is repeated until no further processing is possible. The leftover is stored in the storage tank, and used in the distillery segment for manufacture of distillery products.

The crystallised sugar produced is dried, graded and weighed into various categories based on the size of the crystals and is packed in bags of 50 kgs each.

## **CO-GENERATION**

The activity of sugar manufacturing results in the residue Bagasse, which is used as a bio-fuel for boilers to generate steam and for the rotation of turbines which generates electricity. Our co-generation unit has an installed capacity of total 36.4 MW divided into two turbine generator set of 14 MW and 22.4 MW.

Electricity is a unique commodity which cannot be stored and has to be consumed the moment it is generated. The electricity is partly consumed by our other manufacturing units like Sugar, Distillery and Vinegar. Besides the captive consumption, our Company has installed and maintains transmission lines which transmit the surplus electricity generated by us to our clients. Our Company had entered into a Power Purchase Agreement (PPA) with Electricity Supply Companies (ESCOMs) in the state of Karnataka on February 17, 2017 (PPA). This agreement is valid for a period of five (5) years from the date of commencement of power supply. The distribution companies forming part of the PPA are Bangalore Electricity Supply Company Limited (BESCOM), Mangalore Electricity Supply Company Limited (MESCOM), Gulbarga Electricity Supply Company Limited (GESCOM), Hubli Electricity Supply Company Limited (HESCOM) and Chamundeshwari Electricity Supply Corporation Limited (CESC, Mysore). The aforementioned Power Purchase Agreement mandates us to supply 22.4 MW of power per year. We use approximately 14 MW for captive consumption and the balance is transmitted to various distribution companies as mentioned in the said PPA. However, in times of lower captive electricity consumption, we sell the further surplus through open access market.

## **Plant & Machineries**

For generation of electricity we have installed two (2) boilers, one with a capacity of 70 TPH and the other with a capacity of 80 TPH. Besides, our co-generation unit is equipped with various other state-of-the-art machinery including 2 turbine generation set for 15 MW and 22.4 MW, transformers, alternators, isolators and various boiler and turbine auxiliary machines. We confirm that our Company has not acquired any second hand machinery for this unit.

## **Raw Materials**

### ***Bagasse***

Bagasse is the fibrous residual material that is left after juice has been extracted from sugarcane. The bio-fuel is used for the boilers which generates steam this high pressure steam is blown through the turbines which and is responsible for rotation of turbines. The rotation of turbines generates electricity. The entire bagasse produced as a result of the cane crushing process, is used for the electricity generation process.

### ***Coal***

During off seasons, i.e. May – September, if there is a requirement of production of electricity we procure coal and use the same as bio fuel by burning the same in the Boilers. During this season no crushing takes place and hence there is no supply of bagasse. In this period to continue to generate electricity, we use coal as fuel in the boilers. Also, during crushing season, in case of shortfall of bagasse due to various reasons, we procure coal to fulfil our captive and PPA electricity requirements. Coal is procured through various local and other domestic traders.

## **Manufacturing Process**

The leftover fibrous material after extraction of raw juice from sugarcane is called Bagasse. The technology adopted in co-generation is the Combined Heat and Power cycle, wherein heat and electrical energy is derived from a common source, in our case Bagasse. Bagasse from the mills is carried into the 2 boilers through an automated conveyor belt carrier and used as fuel in the boilers to generate steam. We have two Boilers having 70 TPH and 80 TPH capacities. The burning of fuel results in steam generation which is injected into turbines where it expands and rotates the turbine

at high speed, which in turn rotates the alternator to generate power. This power is used to meet the power requirements to operate the plant and the excess power generated is fed to the grid after upgrading it to 110 KV. The exhaust steam from the turbine, which is at a comparatively low-pressure, is used for boiling in the sugar process.

Also, both our boilers are also equipped to burn coal. This enables us to produce power during off-seasons. Further, the residual steam leaving the turbines still has certain amount of energy, which is utilized in the sugar plant for juice & syrup boiling.

The boilers and turbines of our co-generation plant are equipped with Distributed Control System (DCS). One (1) boiler is installed with Electro Static Precipitator (ESP) and the other boiler has Venturi Wet Scrubber as the air pollution control equipment in order to keep the emissions from the boiler within the prescribed norms of the Pollution Control Board.

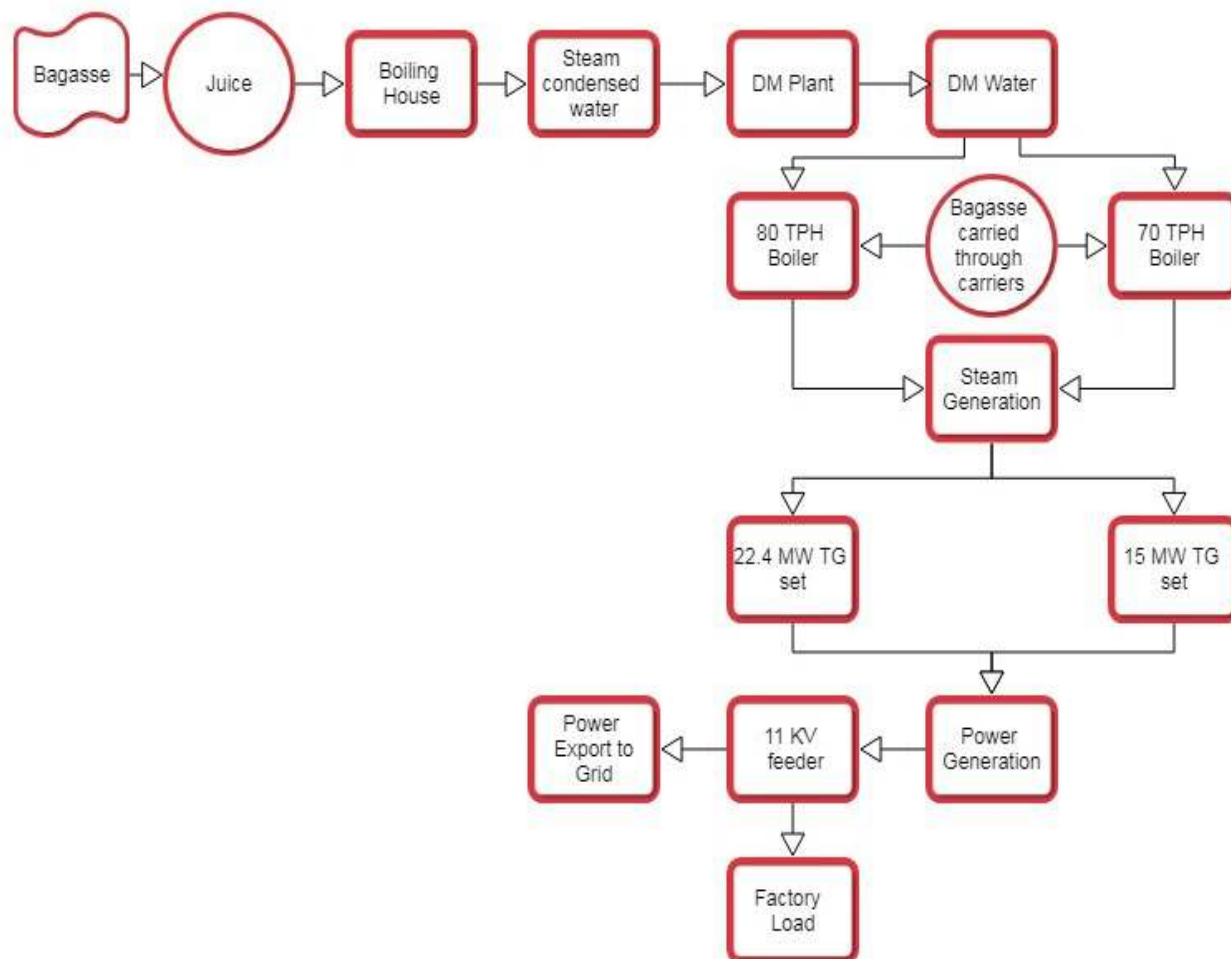

## DISTILLERY PRODUCTS AND INDIAN MADE LIQUOR (IML)

Our Company manufactures Distillery products like Rectified Spirit & Extra-Neutral Spirit and also Indian Made Liquor (IML) from molasses. These products are supplied through Karnataka State Beverages Corporation Limited (KSBCL), who is the sole distributor for all alcoholic products in the State of Karnataka.

Rectified Spirit is a highly concentrated spirit which has been purified by means of repeated distillation. Currently our distillery unit has an installed capacity of 35 KLPD of Rectified Spirit and 30 KLPD of Neutral Spirit. Ethanol produced after fermentation and distillation of Molasses can be further purified into Fuel Ethanol, by removing the water content. The Government, has recently amended the Sugarcane (Control) Order, 1966 vide order S.O. 3663(E)/Ess.Com./Sugarcane dated July 26, 2018 wherein sugar factories have been allowed to manufacture Ethanol from B-Heavy Molasses. Thus our Company intends to manufacture Ethanol which contains a minimum 99.6% ethyl alcohol that is used for blending with petrol and other fuel products. This ethyl alcohol is extracted from the residue mixture using fractional distillation process.

Fuel Ethanol contains various impurities like Esters, Aldehyde and Ketones which needs to be removed to make the Ethanol potable. Once it is re-distilled, the product obtained is devoid of impurities and is odourless which is called Extra Neutral Spirit / Extra Neutral Alcohol (ENA). The ENA is a product suitable for potable purposes and can be further blended and bottled to be marketed as IML products. Ethanol is also denatured and can be used for industrial use.

We manufacture IML products and currently sell Whisky primarily under our brands “VSL Deluxe Whisky”. The ENA manufactured is mixed with demineralised water to form the base liquor which contains about 42% alcohol by volume. To manufacture whisky, special malts, flavours and colouring agents are blended in the base liquor. A good whisky is obtained based on the length of maturing the blended mix is kept for. Upon sufficient maturing period, the blended mix is passed through pressure filters to remove any impurities and then bottled in various marketable packs. Our Company also has obtained a Tetra Packaging machine where whisky is packed in tetra packs which make them easy to carry and dispose.

### **Plant & Machineries**

We have installed the latest machinery for fermentation, distillation, blending processes required for manufacture of Rectified Spirit, ENA and IML. The major plant and machineries used in our distillery unit includes various types of condensers, separators, Aldehyde column, coolers, boilers & re-boilers, decanters and tanks, rotameters and pumps. We also use 2 small boilers in the distillery unit for 12 TPH and 10 TPH. The effluent treatment machines used post the distillation process includes bio-digester, various pumps, biogas breakers, air compressors, vacuum breakers, vents and tanks.

Our IML unit is equipped with the latest machineries including tanks for different stages of process, filter machines and different types of pumps. Further, we have set-up a manual line, an auto line and an auto gravity machine for our IML bottling section. Besides, we have also recently installed a Tetra Packaging machine for our IML products providing us latest technology in IML packaging.

We confirm that our Company has not acquired any second hand machinery for this unit.

### **Raw Material**

The main raw material for production of Rectified Spirit is Molasses, which is a by-product of sugar production process. Molasses retain some amount of sugar, but this sugar cannot be extracted by usual technology used for sugar production. It is used as an input in distilleries where the sugar present in the molasses is fermented into Ethanol / Rectified Spirit. Our Company produces enough molasses for the manufacture of all distillery related products in our Company. Also, after captive consumption, we sell the surplus molasses, if any, to other distillery units.

Apart from molasses, we also use other raw materials, mainly in the manufacture of IML products. Essence blend is added to the base liquor and is required to impart a good taste to the IML. Malt is obtained by soaking a base cereal (such as wheat, rye, oat, rice etc.), allowing it to germinate and then stopping the germination with heat. Malt is purchased by us and added to the matured blended mix. Essence Blend and Malt are mainly procured from Tamil Nadu, as it is a major market for these products. We also purchase Bottles for bottling process of the final purified IML. These bottles are sterilised and the bottling takes place on an automated bottling machine. The bottles are procured from various manufactures and vendors available locally.

### **Manufacturing Process**

The manufacture of Rectified Spirit is a two stage process–

The required amount of acidified yeast is transferred to the pre-fermentation tank and filled with molasses. This mix is allowed to ferment for 5 to 7 hours and during this period the yeast starts its activity. Air is bubbled for a few minutes. After initial fermentation, the mix is transferred to the main fermentation tank and filled with molasses. Fermentation tanks are filled to three forth of their capacity; this is to accommodate the increase in volume due to forming during the periods of fermentation. It takes a total of 40 hours to complete the fermentation process. The end result of the process is “fermented wash” and is transferred to the Clarified wash tank.

The alcohol in the pre-heated Fermented Wash is stripped off by ascending the vapours in the Analyser column. The alcoholic vapours are condensed in the Evaporators in the Integrated Evaporation Machine known as the De-Gassing machine.



Column. The condensed alcoholic vapours are taken to the pre-rectifier feed tank. Analyser Condensate (alcohol condensate) is concentrated in pre-rectifier column, which operates under atmospheric pressure. Condensing steam provides energy to pre-rectifier column through a vertical boiler. A Technical Alcohol cut, of a substantial percentage of total spirit is taken from the pre-rectifier column. Concentrated alcohol draw from the Pre-Rectifier column is fed to extractive distillation column for purification. This process leads to manufacture of Rectified Spirit. It is then transferred to the Azeotropic Dehydration Column and results in production of Ethanol which is either sold or used for captive consumption for manufacture of Vinegar.

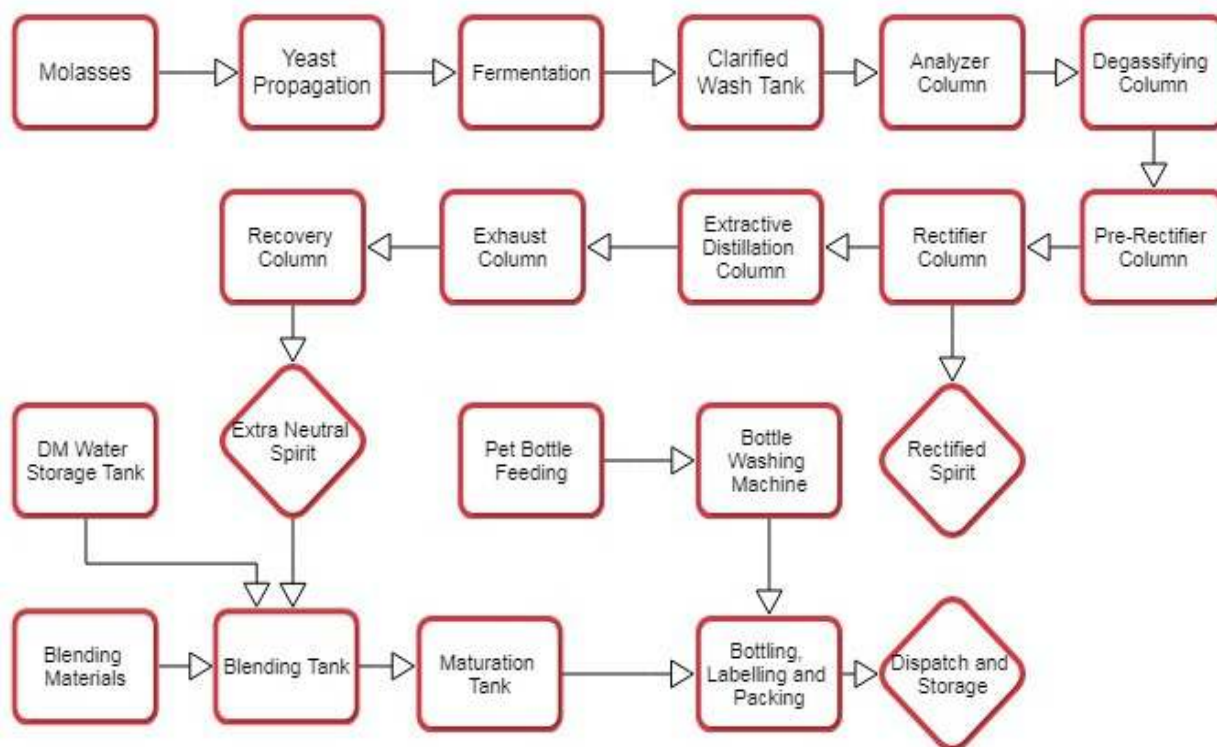

Spent lees and Rectified Spirit are mixed together in the mixing tank and this mixture is taken to the Extractive Distillation column for heating. The top of the Extractive Distillation column is transferred to the exhaust column where the vapours are condensed whereas the bottom of the Extractive Distillation is transferred back to the Rectifier column to enhance the alcoholic content. The condensed liquid from the Exhaust column is transferred to the recovery column from which Extra Neutral Spirit / ENA is recovered.

For manufacture of IML, ENA is mixed with demineralised water to form the base liquor which containing alcohol ranging from 40% – 50% concentration by volume. The base liquor along with essence blend, malt, flavours and colouring agents is mixed in the Blending Tank and transferred to the Maturation Tank to allow the blend to mature for a minimum of seventy two (72) hours. The blend is tested in our in-house labs for colour and base consistency and upon approval, each batch processed by passing it through pressure filters to remove any impurities.

The pet bottles used for bottling the alcohol are cleaned in the bottle washing machine. The final IML is then bottled, labelled and packed into boxes / cartons for either dispatch or to the warehouse.

## VINEGAR

We primarily manufacture vinegar which is non-potable in nature and mainly sold either for industrial purposes or for further processing to convert it as a preservative and for domestic consumption purposes. Basic Vinegar, being a mild acid, has large industrial application mainly as a cleaning agent. However, our major Vinegar sales are for use as a preservative while exporting raw vegetables and fruits. We have an installed capacity for manufacture of Vinegar of 75 KL per annum.

## Plant & Machineries

The various plant and machinery used in our Vinegar Unit include an acetator, air aspiration system, filtration unit and various types & sizes of tanks & pumps. We confirm that our Company has not acquired any second hand machinery for this unit.

## Raw Materials

The basic raw material required for production of vinegar is diluted ethanol which is further fermented. The Ethanol produced by us in the distillery process is used in the manufacture of Vinegar. For the fermentation process, a special bacterium is used, which oxidizes the sugars or ethanol and produce acetic acid during fermentation. We import the bacteria from Germany only once a year and the same is cultivated for a year by our in-house lab chemists.

## Manufacturing Process

The raw materials viz. alcohol, water and imported bacteria (collectively called as “mash”) are mixed into the Charge Tank in the correct proportion. The tank is provided with an agitator through a transfer pump to ensure proper mixing of the raw materials.

The acetator facilitates fermentation of the mash under controlled atmospheric conditions. Since conversion of alcohol into vinegar is basically an oxidation process, fresh oxygen is supplied vide natural air aspirator. The temperature required is maintained by circulating chilled water inside a coil mounted within the acetator. The vinegar obtained from the acetator is cloudy in nature and requires filtration. The cloudy vinegar is received at the discharge tank and then pumped for filtration. The filtration process may not adequately filter the vinegar to the desired levels and is hence re-transferred to the circulation tank where it is goes through the process again and when no further processing is possible, sludge is released in the sludge storage tank. The filtered Vinegar is stored at the filtrate tank and is pumped to the vinegar storage tank.

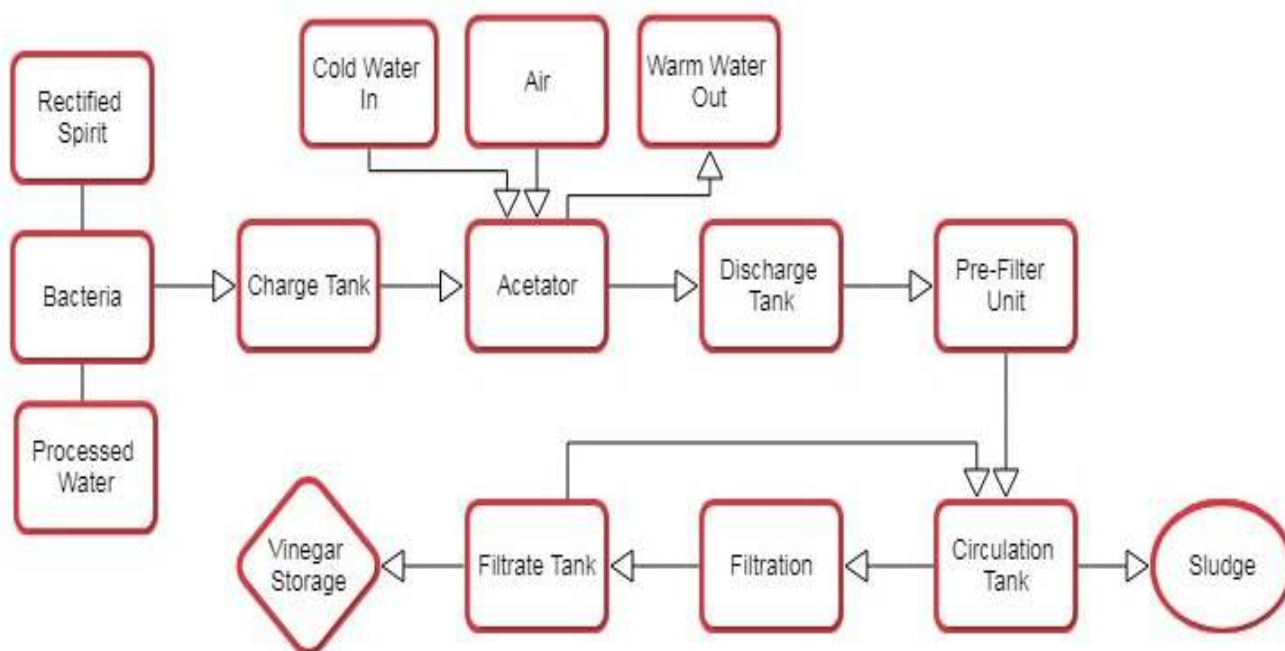

## OTHER BY-PRODUCTS

Besides the above described products, we generate other captive use and / or saleable by-products, mainly from the manufacture of Sugar and Vinegar.

### Carbon Di-Oxide

The process of fermentation of Molasses into Ethanol releases Carbon Di-Oxide (CO<sub>2</sub>) gas which is in a crude form. This crude CO<sub>2</sub> undergoes a series of processes including pre-chilling, water scrubbing, chiller compressing and is also

passed through an activated carbon filter for purification resulting in Liquefied CO<sub>2</sub>. Our Company supplies Liquefied CO<sub>2</sub> to various clients who use it for industrial purposes like chilling and cold storage, industrial cleaning, and also some agricultural uses.

We also sell the Crude CO<sub>2</sub> to Excellences Carbonic Pvt. Ltd. with whom we have entered into an Inclusive Agreement for sale of Crude CO<sub>2</sub> and simultaneously providing to them electricity, water and steam for processing the CO<sub>2</sub> into Liquid CO<sub>2</sub>.

### **Press Mud**

Pressmud is used as manure in sugarcane fields to increase the fertility of the soil and ensure improved yields. Press mud is produced from the residue which comes out from the factory after the filtration of sugarcane juice. The clarification process separates the juice into a clear juice that rises to the top and goes for manufacture, and a mud that collects at the bottom. Press Mud is used for manufacture of Compost fertilizers. However Press Mud is also sold to vendors who use it for various purposes such as manufacture of fertilizers, manufacture of cement etc.

### **Compost**

Compost is a organic manure prepared from waste arising from the factory. The composting process involves an interaction between the organic waste, microorganisms, moisture and oxygen. It mainly involves mixing of two waste materials, one from the Sugar manufacturing process (Press Mud) and one from the Distillery unit (Spent Wash). Spent wash is the unwanted residual liquid waste generated during alcohol production. The Compost is an organic matter that has been decomposed and recycled as a fertilizer and soil amendment and is one of the key ingredient in organic farming.

### **Boiler Ash**

Boiler Ash generated from burning bagasse and / or coal in the Boilers installed in our Co-generation unit. It is sold by our Company to various cement and brick manufacturing companies.

## **INSTALLED CAPACITY**

Below is the Installed and Utilised Capacity for the last three years:

Product	Particulars	for the Financial Year		
		2016-17	2017-18	2018-19
<b>(A) Sugar Unit</b>				
Sugar	Installed Cane Crushing Capacity (TCD)	8,500.00	8,500.00	8,500.00
	No. of days worked	62.00	104.00	119.00
	Average Sugar Capacity (MT / year)	54,544.50	98,389.20	1,13,288.00
	Total Sugar Production (MT / year)	32,170.00	56,335.00	98,415.00
	Capacity Utilised (%)	58.98%	57.26%	86.87%
	Total Bagasse Production (MT / year)	91,960.00	1,43,842.00	2,52,400.00
	Total Molasses Production (MT / year)	15,500.00	24,800.00	43,050.00
<b>(B) Co-Generation Unit</b>				
Power Generation	Installed Capacity MW	36.40	36.40	36.40
	No. of days worked	83.00	203.00	159.00
	Utilised Capacity MW	28.01	12.08	21.18
	Utilised Capacity (%)	76.95%	33.18%	58.19%
<b>(C) Distillery Unit</b>				
Rectified Spirits	Installed Capacity (KLPD)	35.00	35.00	35.00
	Utilised Capacity (KLPD)	31.12	30.74	30.35
	Utilised Capacity (%)	88.92%	87.82%	86.72%
Neutral Spirits	Installed Capacity (KLPD)	30.00	30.00	30.00
	Utilised Capacity (KLPD)	7.99	6.59	14.92
	Utilised Capacity (%)	26.63%	21.96%	49.72%

<b>(D) IML</b>				
Indian Made Liquor	Installed Capacity (Boxes per day)	5,000.00	5,000.00	5,000.00
	Utilised Capacity (Boxes per day)	1,266.71	876.39	615.30
	Utilised Capacity (%)	25.33%	17.53%	12.31%
<b>(E) Vinegar Unit</b>				
Industrial Vinegar	Installed Capacity (KL / per year)	75.00	75.00	75.00
	Utilised Capacity (KL / per year)	18.97	38.46	35.93
	Utilised Capacity (%)	25.30%	51.27%	47.91%

We have proposed the below Installed capacity and Utilisation for the next three (3) years based on the assumption of normal Sugarcane crop during each year:

Product	Particulars	for the Financial Year		
		2019-20	2020-21	2021-22
<b>(A) Sugar Unit</b>				
Sugar	Installed Cane Crushing Capacity (TCD)	8,500.00	8,500.00	8,500.00
	No. of days worked	120.00	120.00	120.00
	Average Sugar Capacity (MT / year)	112,200.00	112,200.00	112,200.00
	Capacity Utilised (%)	85.00%	90.00%	90.00%
<b>(B) Co-Generation Unit</b>				
Power Generation	Installed Capacity MW	36.40	36.40	36.40
	Utilized Capacity (%)	58.00%	60.00%	60.00%
<b>(C) Distillery Unit<sup>(1)(2)</sup></b>				
Rectified Spirits	Installed Capacity (KLPD)	100.00	100.00	100.00
	Utilized Capacity (%)	40.00%	50.00%	55.00%
Neutral Spirits	Installed Capacity (KLPD)	50.00	50.00	50.00
	Utilized Capacity (%)	20.00%	25.00%	35.00%
<b>(D) IML</b>				
Indian Made Liquor	Installed Capacity (Boxes per day)	5,000.00	5,000.00	5,000.00
	Utilized Capacity (%)	20.00%	25.00%	35.00%
<b>(E) Vinegar Unit</b>				
Industrial Vinegar	Installed Capacity (KLPD)	75.00	75.00	75.00
	Utilized Capacity (%)	50.00%	50.00%	50.00%

<sup>(1)</sup> Our Company is in the process of expansion of its distillery capacity and the construction and installation is under process. The Company will be applying for the increased capacity with the relevant authorities upon completion of the construction and installation work.

<sup>(2)</sup> Based on the recent amendment to the Sugarcane (Control) Order, 1966 vide order S.O. 3663(E)/Ess.Com./Sugarcane dated July 26, 2018, our Company intends to manufacture Ethanol from B-Heavy Molasses and accordingly the installed capacity of Ethanol currently is 30 KLPD and relevant applications will be made for the same upon completion of the construction and installation work of the distillery unit.

Our capacity utilisation is primarily based on sugarcane crushed during each Crushing Season and thus there is substantial fluctuation in the capacity utilisation of majority of our products in case of lower or higher sugarcane availability. Correspondingly, our projected capacities are based on the assumption of normal sugarcane production and thus the projections may be higher than 25% of the actual average production of the last three years. For risks involved, please see the risk factor – “We may not be able to achieve our projected capacity in case of low availability of sugarcane and / or higher sugarcane prices, which may affect our business strategies and financial condition”; on page no. 30 of the Red Herring Prospectus.

## OUR MAJOR CUSTOMERS & SUPPLIERS

Our Company is primarily engaged in the production of sugar, power generation (electricity), distillery (Rectified Spirit and Extra Neutral Spirit), IML, Vinegar and other products.

The contribution of the top ten (10) customers to the total turnover of our Company in the last three financial years is as given below:

(₹ in lakhs)

Particulars	For year ended					
	March 2019	%	March 2018	%	March 2017	%
Sales from Top 10 Customers <sup>(1)</sup>	12,657.02	41.26%	8,201.22	31.63%	16,638.77	51.70%

<sup>(1)</sup> We confirm that there is no direct/indirect relationship between the customers forming part of the above top 10 and our Company and our promoters/directors.

The contribution of the top five (5) suppliers to the total purchases of our Company in the last three financial years along with the direct/indirect relationship, if any, between such entities and our Company, and our promoters/directors is as given below:

(₹ in lakhs)

Particulars	For year ended					
	March 2019	%	March 2018	%	March 2017	%
Purchases from Top 5 Suppliers <sup>(1)</sup>	1,845.34	6.67%	6,308.66	27.80%	1,323.29	10.32%

<sup>(1)</sup> We confirm that there is no direct/indirect relationship between the suppliers forming part of the above top 5 and our Company and our promoters/directors.

\* There is no routine concentration of suppliers as a percentage of total purchases, however, during the F. Y. 2017-18, due to lower availability of sugarcane, we have made substantial purchase for raw sugar leading to high amount of purchases from certain entities in this period.

## UTILITIES

### Power & Fuel

We have set up our own co-generation unit. Other than for off-season period (May to August) our Company is self sufficient in generating the entire power for its need. During the off-season period the company meets its power requirement by procuring electricity from the Hubli Electricity Supply Company Limited.

In addition to the said self generated power and sanctioned power, the company has installed DG Sets as standby arrangement in all its manufacturing units, which is used in case of need / shortage or requirement of additional power. The DG Set gets its fuel requirement from the petrol pump owned by the Company.

### Water

Owing to the nature of business of the Company, we need uninterrupted water supply, which is why the integrated facility is strategically located at a place where water is adequately available. The reservoir Dhupdal has been built on the confluence of the rivers Hiranyakeshi and Ghatprabha to facilitate irrigation for various industries. After having obtained the necessary approvals from the Irrigation Department of the Government of Karnataka, our Company has laid water lines for uninterrupted supply of water. Our Company has entered into an extension agreement dated July 21, 2016 with the Government of Karnataka for utilization of water from the Ghatprabha River for use of rift irrigation.

### Steam

Steam is used for various processes in the production of sugar, manufacture of distillery products and power generation. We generate our entire steam requirement on a captive basis wherein we use the bagasse (generated during sugar production) and coal (if required) for burning in the boilers installed thus generating steam.

### Emission and Effluent Treatment Plant

Our Company has installed various effective treatment plants which broadly cover our segment wise operations with adequate capacities to treat the effluent generated from all units as per the consent granted by the Karnataka State Pollution Control Board (KSPCB). An effluent from the distillery, the spent wash, is mixed with press mud, which is discharged from sugar plant, and is used to make organic compost. Being involved in the business of Sugar and Distillery the company also produces liquid effluents. All liquid effluents are treated in sophisticated effluent treatment

plants and the treated water is used for plantations within the plant premises. The ash produced as result of burning bagasse or coal is sold to brick and cement manufacturers.

## **OTHER RAW MATERIALS**

### ***Sulphate***

Sulphate is essential for manufacture of sugar. It is the ingredient which is used for the crystallization of syrup obtained from clear juice. We source our requirement of Sulphate from various local vendors and also from vendors in Bangalore.

### ***Lime***

Milk of lime is added to the Juice Sulphater for cleaning process. Lime is obtained from local vendors in our vicinity and is sufficiently available as it is a common chemical substance.

### ***Caustic Soda***

Caustic Soda is used for cleaning the turbine blades which in turn are used in the power generation activity. Caustic Soda is available from various local vendors as it is a common chemical substance.

### ***Packing Material***

The company uses packing material for bottling and boxing of IML, packing of Sugar and other distillery products. The company generally opens an open tender for procuring the various packing materials and orders are placed in bulk quantities.

## **QUALITY CONTROL & QUALITY ASSURANCE**

We place strong emphasis on product and process quality, which we believe is the critical factor contributing to our success. Being in the business of sugar production, alcoholic spirits manufacture by distillation including ethanol, blending and bottling of Indian Made Liquor (IML) and generation of power; requires that we adhere and adopt stringent quality control measures. To assess and facilitate compliance with applicable requirements, we regularly review our quality systems to determine their effectiveness and identify areas for improvement. We operate on dedicated Standard Procedures for all of our product segments, which is critical in quality control.

Following quality control measures are currently adopted by our Company in relation to our Sugar production, Distillery products and Co-generation unit:

### **Sugar Production**

Our Company uses various methods to assess the quality of sugarcane being used for production of sugar along with the quality of bagasse and the sugarcane juice extracted from these sugarcanes. We also monitor the juice clarification process and thereafter syrup and massecuite quality is checked. We have a well equipped laboratory which enables our Company to ensure, monitor and check all the parameters in the various stages of sugar production. The produced sugar undergoes grading for determining the quality and price to be commanded.

### **Distillery products and IML**

The processes involved in the distillery unit use molasses, water and certain chemical processes. In order to obtain alcohol content above 99.60% and the water content only in traces, our Company adheres to strict quality measures for blending and for manufacture of Ethanol or Vinegar as required. Our Company has all the facilities to maintain the quality standards and well equipped laboratory and manpower to check the same. The spirits manufactured are sent to our laboratory on sample basis for testing the alcoholic levels.

We ensure that every batch of Indian Made Liquor (IML) manufactured is tested in-house. Also, a sample of the IML is sent to the Government laboratory, designated by Commissioner of State Excise.



## **Co-generation Unit**

Our Co-generation unit operates boilers at high pressure where the quality of the boiler feed is very stringent and has to be maintained strictly as per the norms of the boiler manufacturer. The water quality is constantly monitored in our in-house laboratory where all testing facilities are available for this purpose and is under constant monitoring.

## **HEALTH, SAFETY AND ENVIRONMENT**

We are committed to protecting the health and safety of our employees and workers working in our factories. We have policies in place for health and safety for our workmen which have the following salient features:

- Compliance with relevant Safety and Statutory Regulations and Rules both in letter and in spirit
- Ensuring cleanliness of work place in compliance with the relevant regulations
- Providing work force with appropriate tools like helmets, gloves, aprons, face masks, etc.
- Knowledge / instructions on work procedures and safety precautions
- Conducting safety training on induction of new employees and workers as well as periodic refresher training
- Conducting classes on first aid training, fire fighting, mock drills, safety audit, risk analysis studies, etc.
- Ongoing assessment on the status of safety, health and environment at the work place and take appropriate measures to improve the same
- Obligation and responsibility on every employee to perform the tasks ensuring complete safety.

## **Unit Monitoring**

We have a state of the art control room set-up inside the manufacturing unit which monitors the entire process of sugar manufacturing and Co-generation unit in real time. It also maintains the various raw material inputs, heating temperatures, air pressure, electricity generation load, etc. from a single work station. The monitoring unit is built with various safety measures and redundancies to give prior alarms in case of any overload or mishap.

## **MARKETING, SALES AND DISTRIBUTION SETUP**

Our Company undertakes marketing for all of its manufactured products, from Sugar to Compost. Our marketing set-up for each segment is explained below:

### ***Sugar Production***

Since the de-regularization of Sugar, our Company has developed a robust marketing and sales team which liaisons with various major brands. Also, after the de-regulation, the price has become highly dynamic and we need to price our products according to these market dynamics. For this, we constantly endeavour to acquire new clients and also retain the existing ones. We sell our manufactured sugar to various wholesalers, stockists and to several FMCG companies. Our Marketing team consists of well experienced and qualified people to maintain and increase relations with our customers.

### ***Co-Generation***

Electricity is a commodity which cannot be stored and has to be consumed the moment it is generated. Our co-generation unit has an installed capacity of 36.4 MW per annum. After our captive consumption requirement is met, we sell the surplus power generated to various Electricity Supply Companies. For this, our Company has currently entered into a Power Purchase Agreement with the Five (5) Electricity Supply Companies namely; Bangalore Electricity Supply Company Limited (BESCOM), Mangalore Electricity Supply Company Limited (MESCOM), Gulbarga Electricity Supply Company Limited (GESCOM), Hubli Electricity Supply Company Limited (HESCOM) and Chamundeshwari Electricity Supply Corporation Limited (CESC, Mysore) and the same is valid for a period of five (5) years from the date of commencement of power supply. The aforementioned PPA mandates us to supply 22.4 MW of power per year. Also, any further surplus power is sold to other local distributors, industrial units or plants on an invoice basis.

### ***Brewery and Distillery Manufacturing:***

In the state of Karnataka, sale of all IML and Distillery products viz. Rectified Spirit / Extra-Neutral Spirit is controlled through a government agency viz. Karnataka State Beverages Corporation Limited (KSBCL). Accordingly, our distillery products and IML are sold through KSBCL, who in turn ensures the sale of these products to several verified

customers. The marketing team of our Company regularly participates in e-tenders / tenders opened by called by various government and Non Government agencies and factories at competitive rates for winning bids for sale of Rectified Spirit. Due to the restrictions placed by the Government, KSBCL is our sole customer for our IMFL sales.

#### **Industrial Vinegar:**

Our Company produces Vinegar which is non-potable and widely used for various industrial purposes or for further processing for domestic consumption. We mainly sell Vinegar to several companies in the food and beverage industry and in the agri-product processing industry. Our marketing team directly approaches various companies for sales pitch. Currently we have several agri-product companies as part of our client list who use our Vinegar as a preservative for raw vegetables and other agricultural products.

#### **By-Products:**

The crushing of sugarcane and subsequent production and manufacture of our products results in the production of various by-products such as Bagasse, Molasses, Carbon Di-Oxide, Boiler Ash and Compost. Bagasse and Molasses is majorly used for captive consumption in our co-generation unit and distillery unit respectively. However, on certain occasions, surplus molasses is sold to other distillery units in the vicinity based on the demand. Our marketing team keeps good relations with various distillery units for ensuring the sale of surplus quantities. The liquefied CO2 is sold to various cold storage houses, medical equipment makers and other industrial users who are regularly contacted by our marketing team. Further, we have entered into an agreement with Excellences Carbonic Pvt. Ltd. for sale of crude Carbon Di-Oxide. Boiler Ash is sold to various local manufacturers of bricks and related products. With the growing infrastructure in Bellad-Bagewadi and other nearby areas, many brick manufacturers have a constant demand for Boiler Ash. Compost is largely sold on a highly subsidised rate to the farmers who grow sugarcane in the nearby villages. This ensures that the farmers in turn sell the sugarcane produce to us on a priority.

#### **MANPOWER**

The production of sugar, manufacturing of distillery and ancillary products and the power generation process requires an appropriate mix of skilled, semi-skilled and un-skilled labour. Belgaum being a border city to both Karnataka, Maharashtra and Goa, labour – skilled, semi-skilled and unskilled – is easily available here. As on July 31, 2019, Our Company had 949 employees.

Besides the above, we also hire labourers from local and nearby areas at our factory premises on a daily wages basis as and when required. Our employees are not unionized into any labourers' or workers' union. We do not employ any Contract Labour in our factory and hence no compliance with The Contract Labour (Regulation & Abolition) Act, 1970 or Rules thereunder is required. We have not experienced any major work stoppages due to labour disputes or cessation of work in the last five years. We believe that we share good and cordial relations with our employees.

The detailed break-up of our employees is as under:

Segment	Directors	KMP / Admin	Workers	Total
Office / General		40	234	274
Sugar Production		51	141	192
Co-Generation		7	201	208
Distillery Unit		5	106	111
Vinegar Unit		-	11	11
By-Products & Miscellaneous		7	142	149

The frequency distribution of the salary of the above employees for the month of July 31, 2019 is as given below:

Frequency (Monthly Salary Range)		No. of Employees
From	To	
1	10,000	682
10,001	20,000	241
20,001	30,000	16
30,001	40,000	1
40,001	50,000	2
60,001	70,000	1

80,001	90,000	2
1,90,001	2,00,000	2
2,20,001	2,30,000	1
2,90,001	3,00,000	1

## EXPORTS AND EXPORT OBLIGATIONS

The total exports of the company for the last three fiscal years i.e., 2018-19, 2017-18 and 2016-17 is ₹ NIL each.

As per the Authorization Forwarding Letter issued by the Additional DGFT dated November 07, 2016, our Company has an export obligation of 6 times the value of duty saved; to be fulfilled within a period of 6 years (the duty saved being ₹ 48,33,203).

## COLLABORATIONS

The Company has so far not entered into any technical or financial collaboration agreement.

## COMPETITION



India is one of the largest sugar producer and consumer in the world. Our Company faces severe competition in the business of Sugar production from sugar mills operating not only in Karnataka and Maharashtra but throughout the country and also from international markets. Though our direct sugar competitors are the sugar mills operating out of North West Karnataka and South West Maharashtra, with the de-regulation of sugar prices, we now have to set sugar prices as per national competition. The competition faced by us is also in the form of sugarcane purchase from farmers from villages in our vicinity and also outside the area of our factory. Further, competition in the sugar industry arises from organised as well as from un-organised sector.

We face scarce competition in our power generation segment in lieu of existing PPA with 5 electricity supply companies, huge demand from our customers and limited competitors.

Our distillery segment faces stiff competition from domestic players as well as local players with regards to pricing our brands vis-à-vis the other IML and IMFL products. Competition in IML is relatively strong from the un-organised market. The distillery segment being highly price sensitive, we respond to our competitors by pricing our alcoholic products suitably.

## INTELLECTUAL PROPERTY

We have registered 2 trademarks as explained below:

Sr. No.	Description		Class	Trademark No.	Status
1.	VSL (Device)		33	2152827	Registered
2.	VSL (Device)		30	2152826	Registered

## PROPERTY

### Freehold Property

The details of the Free Hold property are as under:

Sr. No.	Schedule of property and area	Purpose
1.	Land bearing Survey Nos. 136, 139, 140:1, 140:2, 140:3, 140:4, 141:1, 148:3, 149:1, 149:2, 149:3, 149:4, 150:1, 150:2A, 150:2B, 151:1, 151:2A, 151:2B, 151:2C and 152 situated at Bellad Bagewadi, Taluka Hukkeri, Bellad Bagewadi 591305, Karnataka, India	Factories, Buildings, Godowns and Sheds

Sr. No.	Schedule of property and area	Purpose
	Area – 132 Acres and 34 Gunthas	
2.	Residential Apartment bearing No. M-104, First Floor of “M-Wing – Lynx” in “Brigade Gateway”, situated in Industrial Suburb, Subramanyanagar, Municipal Ward No. 9, Rajinagar Extension (Malleswaram West), Bangalore – 560010  Area – 2300 square feet  AND  Vacant Land bearing Municipal Nos. 26 and 26/1, New No. 26/1, situated in Industrial Suburb, Subramanyanagar, Municipal Ward No. 9, Rajinagar Extension (Malleswaram West), Bangalore – 560010  Area – 404 square feet	Guest House
3.	Freehold Land situated at R. Sy. No. 204 / 2A, Navage Village, Uchagaon Revenue Circle, Belgaum  Area – 20 Gunthas	Future Expansion purposes <sup>(1)</sup>
4.	Freehold Land situated at R. Sy. No. 206 / A, Navage Village, Uchagaon Revenue Circle, Belgaum  Area – 3 Acres and 34 Gunthas <sup>(2)</sup>	Future Expansion purposes <sup>(1)</sup>
5.	Freehold Land situated at R. Sy. No. 206 / B, Navage Village, Uchagaon Revenue Circle, Belgaum  Area – 3 Acres and 6 Gunthas <sup>(2)</sup>	Future Expansion purposes <sup>(1)</sup>
6.	Freehold Land situated at R. Sy. No. 207 / 1, Navage Village, Uchagaon Revenue Circle, Belgaum  Area – 1 Acre and 32 Gunthas <sup>(2)</sup>	Future Expansion purposes <sup>(2)</sup>

<sup>(1)</sup> These properties have been acquired pursuant to registered POA and the final sale deeds for the same are under process. We confirm that none of the Sellers are belongs to our Promoter, Promoter Group & Directors of our Company. Please refer the risk factor – “We have acquired certain land for a proposed expansion, where the power of attorney (‘POA’) holder for the seller is the Whole time Director of our Company. Further, the final sale deed has not yet been executed” on page no. 26 of this Red Herring Prospectus.

<sup>(2)</sup> Each R. Sy. No. has been acquired from multiple owners of small parcels of land. We confirm that none of the Sellers are belongs to our Promoter, Promoter Group & Directors of our Company.

#### Lease Property

Sr. No.	Name of the Lessor	Premises Leased and area	Term of the Lease	Purpose
1.	Prakash Shrishailappa Katti	Survey No. 134/2, Off Ghartprabha – Chikodi Road, Hukkeri Taluka, District Belgaum, 591 305  Area – 2 Acres	20 years from August 16, 2006 to August 15, 2026.	Consumer Diesel Pump
2.	Prakash Shrishailappa Katti	Survey No. 134/2, Off Gokak Road, Hukkeri Taluka, District Belgaum, 591 305  Area – 5 Acres	20 years from June 07, 2017 to June 06, 2037	Staff Quarters
3.	Nikhil Umesh Katti	4 <sup>th</sup> Floor along with terrace, CTS No. 8692/A, Sector No. III, Shivbasv Nagar, Mal-Maruti Extension, Belgaum  Area – 1543 Yards / 0.32 Acre	10 years from August 21, 2013 to August 20, 2023	Guest House

## INSURANCES

The insurance policies covered by the company are:

Sr. No.	Name of the Insurance Company	Type of Policy	Validity Period	Description of cover under the policy	Policy No.	Sum Insured (₹ lakhs)	Premium p.a. (₹ in lakhs)
1.	New India Assurance Company Limited	Standard Fire & Special Perils Policy	From January 23, 2019 to January 22, 2020	As per Note 1	68040011180100000423	1,600.00	1.51
2.	New India Assurance Company Limited	Standard Fire & Special Perils Policy	From January 23, 2019 to January 22, 2020	As per Note 2	68040011180100000424	400.00	1.84
3.	New India Assurance Company Limited	Boiler and Pressure Plant Policy	From January 23, 2019 to January 22, 2020	As per Note 3	68040044185200000004	2,200.00	1.04
4.	New India Assurance Company Limited	Boiler and Pressure Plant Policy	From January 23, 2019 to January 22, 2020	As per Note 4	68040044185200000005	2,000.00	1.75
5.	New India Assurance Company Limited	Standard Fire & Special Perils Policy	From January 23, 2019 to January 22, 2020	As per Note 5	68040011180100000428	4,600.00	2.78
6.	New India Assurance Company Limited	Machinery Insurance Policy	From January 23, 2019 to January 22, 2020	As per Note 6	68040044185100000021	2,975.00	13.51
7.	New India Assurance Company Limited	Machinery Insurance Policy	From January 23, 2019 to January 22, 2020	As per Note 7	68040044185100000022	776.03	5.49
8.	New India Assurance Company Limited	Electronic Equipment Insurance Policy	From January 23, 2019 to January 22, 2020	As per Note 8	68040044185800000010	191.64	0.61
9.	New India Assurance Company Limited	Employees – Hospitalization Insurance	From January 23, 2019 to January 22, 2020	As per Note 9	68040048186800000016	As per Note 9	2.03
10.	New India Assurance Company Limited	Employees Accident Insurance	From January 23, 2019 to January 22, 2020	As per Note 10	68040042180100000054	2,832.00	3.01
11.	New India Assurance Company Limited	Standard Fire & Special Perils Policy	From January 23, 2019 to January 22, 2020	As per Note 11	68040011180100000431	500.00	0.21
12.	New India Assurance Company Limited	Marine Cargo Open Policy	From January 23, 2019 to January 22, 2020	As per Note 12	68040021180200000004	10,000.00	4.72
13.	New India Assurance Company Limited	Standard Fire & Special Perils Policy	From January 23, 2019 to January 22, 2020	As per Note 13	68040011180100000426	750.00	0.35

14.	New India Assurance Company Limited	Standard Fire & Special Perils Policy	From January 23, 2019 to January 22, 2020	As per Note 14	68040011180100000427	180.00	0.64
15.	New India Assurance Company Limited	Standard Fire & Special Perils Policy	From January 23, 2019 to January 22, 2020	As per Note 15	68040011180100000429	19,500.00	9.33
16.	New India Assurance Company Limited	Burglary Insurance	From January 23, 2019 to January 22, 2020	As per Note 16	68040046180100000040	10,000.00	2.36
17.	New India Assurance Company Limited	Standard Fire & Special Perils Policy	From January 23, 2019 to January 22, 2020	As per Note 17	68040011180100000432	160.00	0.76
18.	New India Assurance Company Limited	Standard Fire & Special Perils Policy	From January 23, 2019 to January 22, 2020	As per Note 18	68040011180100000421	12,000.00	6.37
19.	New India Assurance Company Limited	Standard Fire & Special Perils Policy	From January 23, 2019 to January 22, 2020	As per Note 19	68040011180100000422	12,000.00	6.37
20.	New India Assurance Company Limited	Standard Fire & Special Perils Policy	From January 31, 2019 to January 30, 2020	As per Note 20	68040011180100000420	5,800.00	8.04
21.	New India Assurance Company Limited	Burglary Insurance Policy	From January 31, 2019 to January 30, 2020	As per Note 21	68040046180100000039	5,800.00	2.05
22.	New India Assurance Company Limited	Machinery Insurance Policy	From January 23, 2019 to January 22, 2020	As per Note 22	68040044185100000019	2,300.00	12.21
23.	New India Assurance Company Limited	Machinery Insurance Policy	From January 23, 2019 to January 22, 2020	As per Note 23	68040044185100000020	1,375.00	7.30
24.	New India Assurance Company Limited	Standard Fire & Special Perils Policy	From January 23, 2019 to January 22, 2020	As per Note 24	68040011180100000425	2,525.00	1.43

**Notes:**

1. On stock of loose or press bales Baggase in open in Baggase yard situated at Bellad Bagewadi, Taluka Hukkeri, District Belgaum – 591 305
2. On stock of loose or press bales Baggase in open in outside manufacturing compound situated at Bellad Bagewadi, Taluka Hukkeri, District Belgaum – 591 305
3. Boiler – ISGECJHON THOMPSON Boiler with it accessories – 80 TPH KTK 3478 MICR 67 Kg/SQCM, 510 DEG.C
4. Boiler – ISGECJHON THOMPSON Boiler with it Accessories – 70 TPH KTK 2760 MICR. 67 Kg/SQCM, 485 DGC
5. Various buildings including P & F etc., P & M & all its accessories, F/F/F including E/I, IML stored in various tanks and bottles and stock of Molasses in open & in tanks or in process.
6. Various Electrical and Mechanical Equipments & Transformers, Gear Boxes in various departments of VSIL
7. All electrical motors & sugar mill electrical VFD in various departments in sugar factory and co generation unit.
8. All types of electronic equipment in various departments of VSIL



9. Raasta Aaptti Kavach policy for 944 employees of VSIL (all departments) with sum insured of ₹ 1,00,000 as compensation for Road Accident, ₹ 1,00,000 as hospitalization for Road Accident and ₹ 1,00,000 hospitalization expenses for employment extension; per employee.
10. Accident Insurance for 944 employees of VSIL (all departments)
11. Guest House building including F / F / F, interior decoration, electrical installation, air conditioner, kitchenware, utensils, fridge, ovens, crockery & glass ware and such others.
12. IML packed in cartons containing pet, glass bottles and tetra pack of 90ml, 180ml, 375ml, 750ml and 1ltr.
13. On Administrative Office Building, F.F.F. Interior Decoration, Electrical Installation, Air Conditioner, Computers and accessories and Stationery etc.
14. On 112 No. of staff residential quarters / flats in six blocks, each flat and each flat F.F.F. & electrical installation.
15. Building including superstructure, plinth and foundation, plant, machinery & accessories, F.F.F. and compound wall for the Sugar & Co-gen Plant of VSIL
16. On stock of sugar in PP gunny bags or gunny bags stored in sugar godown nos. 1, 2, 3 & 4 situated at VSIL.
17. On Class A construction godowns know as godown nos. 1, 2, 3 & 4 in VSIL compound including plinth and foundation.
18. On stock of sugar in PP bags or gunny bags / loose, stored in class A construction godown nos. 1 & 2 situated within factory premises of VSIL.
19. On stock of sugar in PP bags or gunny bags / loose, stored in class A construction godown nos. 3 & 4 situated within factory premises of VSIL.
20. On stock of sugar in PP bags or gunny bags / loose, stored in open (open stacking covered with poletthne tarpaulin), situated within factory premises of VSIL.
21. On stock of sugar in PP / gunny bags, stored in open stacking at VSIL.
22. Description of machinery insured – a) Turbo Generator Shin Nippon Japan 22.4 MW 4922 RPM SL No. 21901. b) Turbo Generator Seisa Gear Box 1500 RPM Sl. No. 07KADA61. c) Turbo Generator Sl. No. 2K80862301.
23. Description of machinery insured – a) Turbo Generator Shin Nippon Japan 15 MW SL No. 21100. b) SEISA Gear Box 8000/1500 RPM NDM 6067 Sl. No. 6067. c) TDPS Turbine Generator Set 18750 KVA Sl. No. 2K3022401.
24. On VSIL vinegar unit, building, plant & machinery, stock - raw material & finished product and stock in process of various grades and stored in various tanks and such others belonging to vinegar project.

## KEY REGULATIONS AND POLICIES

In carrying on our business as described in the section titled “*Our Business*” on page no. 130 of this Red Herring Prospectus, our Company is regulated by the following legislations in India. The following description is a summary of the relevant regulations and policies as prescribed by the Government of India and other regulatory bodies that are applicable to our business. The information detailed in this Chapter has been obtained from the various legislations, including rules and regulations promulgated by the regulatory bodies and the bye laws of the respective local authorities that are available in the public domain. The regulations and policies set out below may not be exhaustive and are only intended to provide general information to the investors and are neither designed nor intended to be a substitute for professional legal advice. For details of Government Approvals obtained by the Company in compliance with these regulations, kindly refer to the Chapter titled “*Government and Other Key Approvals*” beginning on page no. 300 of this Red Herring Prospectus.

### A. INDUSTRY RELATED LEGISLATIONS:

#### 1. The Food Safety and Standards Act, 2006

The Food Safety and Standards Act, 2006 (the “**FSS Act**”) is the primary legislation in India relating to food and the corresponding safety standards. The FSS Act *inter-alia* mandates that no food business operator shall himself or by any person on his behalf manufacture, store, sell or distribute any article of food—

- i. which is unsafe; or
- ii. which is misbranded or sub-standard or contains extraneous matter; or
- iii. for which a licence is required, except in accordance with the conditions of the licence; and
- iv. which is for the time being prohibited by the Food Authority or the Central Government or the State Government in the interest of public health.

Section 3(j) of the FSS Act defines ‘food’ and *inter-alia* includes packaged drinking water within the scope of the definition of ‘food’. Further, every person who carries on food business is required to obtain a license under the FSS Act. The Food Safety and Standards Authority of India (“**FSSAI**”) has been established under the FSS Act.

The FSSAI has the power to regulate and monitor the manufacture, processing, distribution, sale and import of food so as to ensure safe food. It *inter-alia* has the power to regulate the quality control of articles of food imported in India, limits on use of additives, metals, drugs and anti-biotics in food, certification of bodies engaged in food safety management systems and food labelling standards. The FSSAI is obliged to provide scientific advice and technical support to the Central Government and the State Governments in framing the policies and rules in areas which have a direct or indirect bearing on food safety and nutrition. The FSS Act also provides power to the Food Safety Officer to enter and inspect any place where articles of food are manufactured, or stored for sale, or stored for the manufacture of any other article of food, or exposed or exhibited for sale and where any adulterant is manufactured or kept, and take samples of such articles of food or adulterant for analysis. Further, any person who whether by himself or by any other person on his behalf manufactures for sale or stores or sells or distributes or imports any article of food for human consumption which is sub-standard, shall be liable to a penalty which may extend to five lakh rupees. The FSSAI has also framed the several rules and regulations relating to food safety and standards with regard to sale, packaging and labelling, analysis, additives and contaminants.

#### 2. The Factories Act, 1948

The Factories Act, 1948 (“**Factories Act**”) seeks to regulate labour employed in factories and makes provisions for the safety, health and welfare of the workers. An occupier of a factory under the Factories Act, means the person who has ultimate control over the affairs of the factory. The occupier or manager of the factory is required to obtain a registration for the factory. The Factories Act also requires *inter alia* the maintenance of various registers dealing with safety, labour standards, holidays and extent of child labour including their conditions. Further, notice of accident or dangerous occurrence in the factory is to be provided to the inspector by the manager of the factory.

### **3. The Indian Boiler Act, 1923**

The Indian Boiler Act expressly provided in the Act that no owner of a boiler shall use the boiler or permit it to be used unless it has been registered in accordance with the provisions of this Act. The Act Further provides that any owner of a boiler who, in any case in which a certificate or provisional order is required for the uses of the boiler under this Act, uses the boiler either without any such certificate or order being in force or at a higher pressure than that allowed thereby, shall be punishable with fine which may extend to five hundred rupees, and in the case of a continuing offence, with an additional fine which may extend to one hundred rupees for each day after the first day in regard to which he is convicted of having persisted in the offence.

### **4. The Petroleum Act, 1934**

The Petroleum Act, 1934 (“Petroleum Act”) has been enacted to provide for the regulation of import, transport, storage, production, refining and blending of petroleum. The Petroleum Act mandates that no one shall import, transport, store, produce, refine and blend any petroleum save in accordance with the rules made under Act. Further, every person who carries on import, export or storage of petroleum is required to obtain a license in accordance with the conditions for the purpose which he may be required to obtain by the rules made under the Petroleum Act.

Further, if any person acts in contravention of any of the provisions or of any of the rules made thereunder, imports, transports, stores, produces, refines or blends any petroleum shall be punishable with simple imprisonment which may extend three months, or with fine which may extend to five thousand rupees, or with both.

### **5. The Legal Metrology Act, 2009**

The Legal Metrology Act, 2009 (“**L.M. Act**”) governs the standards/units/denominations used for weights and measures as well as for goods which are sold or distributed by weight, measure or number. It also states that any transaction/contract relating to goods/class of goods shall be as per the weight/measurement/numbers prescribed by the L.M. Act. Moreover, the L.M. Act prohibits any person from quoting any price, issuing a price list, cash memo or other document, in relation to goods or things, otherwise than in accordance with the provisions of the L. M. Act. The specifications with respect to the exact denomination of the weight of goods to be considered in transactions are contained in the Rules made by each State. The L.M. Act also provides for Legal Metrology (General) Rules, 2011, which may be followed for due compliance, if the respective State does not provide for rules in this regard.

Additionally, the L.M. Act provides for the following penalties in case of contravention of certain provisions thereof:

1. Penalty for use of weight, measure or numeration in contravention of the L.M. Act;
2. Penalty for alteration or tampering with the weight or measure;
3. Penalty for making a transaction, deal or contract in contravention of the L.M. Act.
4. Penalty for the buyer (buying in excess of the quantity specified, or price paid for) and seller (selling less the quantity specified, or price paid for).

### **6. Electricity Act, 2003**

The Electricity Act repealed the previous Indian legislation pertaining to electricity in India namely the Indian Electricity Act, 1910, the Electricity (Supply) Act, 1948 and the Electricity Regulatory Commissions Act, 1998 and was brought into force on June 10, 2003. The Electricity Act and the rules and regulations made there under primarily govern the generation, transmission, distribution, trading and use of electricity

### **7. The National Electricity Policy, 2005**

On February 12, 2005, the Ministry of Power has notified the National Electricity Policy. The National Electricity Policy lays down guidelines for accelerated development of the power sector, providing supply of electricity to all areas and protecting interests of consumers and other stakeholders keeping in view availability of energy resources,

technology available to exploit these resources, economics of generation using different resources, and energy security issues with an aim of providing universal access to electricity.

#### **8. Essential Commodities Act, 1955**

The Essential Commodities Act, 1955 (the "Essential Act") provides for the control of the production, supply, sales, storage, distribution etc. in certain commodities including sugar. Section 3 of the Essential Act empowers the Central Government to issue directions to control production, supply, distribution etc. of the 'essential commodity' produced by the manufacturer or stock holders, and also makes specific provision with regard to the amount payable for the levy sugar sold by the producer. The levy sugar price is fixed by the Central Government as per the provisions of Section 3C of the Essential Act. The Central Government is also empowered to direct that no producer, importer or exporter shall sell or otherwise dispose of or deliver any kind of sugar or remove from the bonded godown of the factory in which it is produced, except in accordance with the directions issued by the Government. Further, all kinds of sugar including plantation white sugar, raw sugar and refined sugar, whether indigenously produced or imported, fall within the scope of powers of the Central Government for directions in regard to, inter alia, stock, disposal or delivery.

#### **9. Prevention of Food Adulteration Act, 1976**

Usually under the Prevention of Food Adulteration Act, 1976, a license is required to be obtained from the Local Health Authority for the production and sale of sugar and Molasses.

#### **10. Sugar Control Order, 1966**

The Sugar (Control) Order 1966 provides for power to the Government to regulate production of sugar, restrict sale etc. of sugar by producers, movement of sugar and quality of sugar, call for information from producer or recognised dealer, inspection, entry, search, sampling and seizure of sugar and delegation of powers conferred by the Sugar (Control) Order, 1966 to any officer or authority of the Central or State Government. On the basis of the quarterly free sale quota decided by the Government, month-to-month release orders for sale of sugar in open market are issued under clause 5 of the Sugar (Control) Order, 1966.

#### **11. Sugarcane (Control) Order, 1966**

Under the aforesaid Order, the Central Government is empowered to fix the minimum price of sugarcane to be paid by producers of the sugar for sugarcane purchased by them having regard to certain factors as mentioned in Clause 3 of the said Order. Further, a different price may be fixed for different areas or different qualities or varieties of sugarcane. Further, the Central Government or the State Government with the approval of the Central Government, may, subject to such conditions as specified in the Order, allow a suitable rebate in the price so fixed. The said Order also contains various provisions for regulating the 133 supply and distribution of sugarcane. The Central Government is empowered to direct the producers of the sugar to pay additional price for sugarcane in addition to the minimum sugarcane prices fixed in accordance with the provisions of the second schedule to the said Order. The Central Government is empowered to delegate certain powers conferred upon it by this Order subject to such restrictions, exceptions and conditions, if any, as the Central Government may think fit.

#### **12. Molasses Control Order, 1966**

The Molasses Control Order, 1961 includes various provisions for regulation of the storage, grading, sale and removal of Molasses. It empowers the Government to fix maximum prices of Molasses.

#### **13. Sugar (Regulation of Production) Act, 1961**

The Sugar (Regulation of Production) Act, 1961 ("Sugar Act") empowers the Central Government to fix the quantity of sugar, which may be produced, in a factory during any year. The Act was meant to provide for the regulation of production of sugar in the interests of general public and for the levy and collection of a special excise duty on sugar produced by a factory in excess of the quota fixed for the purpose.

The following legislations are also applicable to the Company:

- 1) Sugar (Packaging and Marketing) Order, 1970

- 2) Sugar Cess Act, 1982
- 3) Levy Sugar Supply (Control) Order, 1979 as amended by Levy Sugar (Control) Amendment Order, 2000
- 4) Levy Sugar Price Equalization Fund Act, 1976
- 5) Sugar Development Fund Act, 1982
- 6) Sugar Development Fund Rules, 1983

## **B. LABOUR RELATED LEGISLATIONS:**

### **1. Employees Provident Fund and Miscellaneous Provisions Act, 1952 (“EPF Act”)**

Under the Employees Provident Fund and Miscellaneous Provisions Act, 1952 (“**EPF Act**”), compulsory provident fund, family pension fund and deposit linked insurance are payable to employees in factories and other establishments. The legislation provides that an establishment employing more than 20 (twenty) persons, either directly or indirectly, in any capacity whatsoever, is either required to constitute its own provident fund or subscribe to the statutory employee’s provident fund. The employer of such establishment is required to make a monthly contribution to the provident fund equivalent to the amount of the employee’s contribution to the provident fund. There is also a requirement to maintain prescribed records and registers and filing of forms with the concerned authorities. The EPF Act also prescribes penalties for avoiding payments required to be made under the abovementioned schemes.

### **2. Industrial Disputes Act, 1947 and Industrial Dispute (Central) Rules, 1957**

Industrial Dispute Act, 1947 and the Rules made thereunder provide for the investigation and settlement of industrial disputes. The Industrial Disputes Act, 1947 (“**IDA**”) was enacted to make provision for investigation and settlement of industrial disputes and for other purposes specified therein. Workmen under the IDA have been provided with several benefits and are protected under various labor legislations, whilst those persons who have been classified as managerial employees and earning salary beyond a prescribed amount may not generally be afforded statutory benefits or protection, except in certain cases. Employees may also be subject to the terms of their employment contracts with their employer, which contracts are regulated by the provisions of the Indian Contract Act, 1872. The IDA also sets out certain requirements in relation to the termination of the services of the workman. The IDA includes detailed procedure prescribed for resolution of disputes with labor, removal and certain financial obligations up on retrenchment. The Industrial Dispute (Central) Rules, 1957 specify procedural guidelines for lock-outs, closures, lay-offs and retrenchment.

### **3. The Employees’ Compensation Act, 1923**

The Employees’ Compensation Act, 1923 (“**EC Act**”) has been enacted with the objective to provide for the payment of compensation to workmen by employers for injuries caused by accident(s) arising out of and in the course of employment, and for occupational diseases resulting in death or disablement. The EC Act makes every employer liable to pay compensation in accordance with the EC Act if a personal injury/disablement/ loss of life is caused to a workman by accident arising out of and in the course of his employment. In case the employer fails to pay compensation due under the EC Act within 1 (one) month from the date it falls due, the commissioner appointed under the EC Act may direct the employer to pay the compensation amount along with interest and may also impose a penalty.

### **4. Payment of Gratuity Act, 1972**

The Payment of Gratuity Act, 1972 provides for payment of gratuity to employees employed in factories, shops and other establishments who have put in a continuous service of 5 (five) years, in the event of their superannuation, retirement, resignation, death or disablement due to accidents or diseases. The rule of ‘five year continuous service’ is however relaxed in case of death or disablement of an employee. Gratuity is calculated at the rate of 15 (fifteen) days’ wages for every completed year of service with the employer. Presently, an employer is obliged for a maximum gratuity pay out of ₹ 10,00,000/- for an employee.

## 5. The Minimum Wages Act, 1948

The Minimum Wages Act, 1948 (“**MWA Act**”) was enacted to establish minimum wages for certain categories of employees. Under this Act, the Central and the State Governments stipulate the scheduled industries and establishments and fix minimum wages.

## 6. Payment of Bonus Act, 1965

Pursuant to the Payment of Bonus Act, 1965, as amended, an employee in a factory or in any establishment where 20 (twenty) or more persons are employed on any day during an accounting year, who has worked for at least 30 (thirty) working days in a year, is eligible to be paid a bonus. Contravention of the provisions of the Payment of Bonus Act, 1965 by a company is punishable with imprisonment up to six months or a fine up to ₹ 1,000/- or both.

## 7. The Maternity Benefit Act, 1961

The purpose of the Maternity Benefit Act, 1961 is to regulate the employment of pregnant women in certain establishments for certain periods and to ensure that they get paid leave for a specified period before and after childbirth, or miscarriage or medical termination of pregnancy. It inter alia provides for payment of maternity benefits, medical bonus and prohibits the dismissal of and reduction of wages paid to pregnant women.

## 8. The Payment of Wages Act

The Payment of Wages Act, 1936 (“**PWA**”) is applicable to the payment of wages to persons in factories and other establishments. PWA ensures that wages that are payable to the employee are disbursed by the employer within the prescribed time limit and no deductions other than those prescribed by the law are made by the employer.

## 9. Equal Remuneration Act, 1979

Equal Remuneration Act, 1979 provides for payment of equal remuneration to men and women workers and for prevention discrimination, on the ground of sex, against female employees in the matters of employment and for matters connected therewith.

## 10. The Sexual Harassment of Women at Workplace (Prevention, Prohibition and Redressal) Act, 2013

The Sexual Harassment of Women at Workplace (Prevention, Prohibition and Redressal) Act, 2013 (“**SHWW Act**”) provides for the protection of women at work place and prevention of sexual harassment at work place. The SHWW Act also provides for a redressal mechanism to manage complaints in this regard. Sexual harassment includes one or more of the following acts or behaviour namely, physical contact and advances or a demand or request for sexual favours or making sexually coloured remarks, showing pornography or any other unwelcome physical, verbal or non-verbal conduct of sexual nature. The SHWW Act makes it mandatory for every employer of a workplace to constitute an Internal Complaints Committee which shall always be presided upon by a woman. It also provides for the manner and time period within which a complaint shall be made to the Internal Complaints Committee i.e. a written complaint is to be made within a period of 3 (three) months from the date of the last incident. If the establishment has less than 10 (ten) employees, then the complaints from employees of such establishments as also complaints made against the employer himself shall be received by the Local Complaints Committee. The penalty for non-compliance with any provision of the SHWW Act shall be punishable with a fine extending to ₹ 50,000/-

## 11. Child Labour (Prohibition and Regulation) Act, 1986

The Child Labour (Prohibition and Regulation) Act, 1986 (the “**CLPR Act**”) seeks to prohibit the engagement of children in certain employments and to regulate the conditions of work of children in certain other employments. It also prescribes hours and periods of work, holidays, the requirement of keeping a register, etc for the establishments falling under this act. A shop or a commercial establishment is included under the definition of an “establishment” according to Section 2(iv).

## C. ENVIRONMENTAL REGULATIONS:

Our Company is also required to obtain clearances under the Environment (Protection) Act, 1986, and other environmental laws such as the Water (Prevention and Control of Pollution) Act, 1974, the Water (Prevention



and Control of Pollution) Cess Act, 1977 and the Air (Prevention and Control of Pollution) Act, 1981, before commencing its operations. To obtain an environmental clearance, a no-objection certificate from the concerned state pollution control board must first be obtained, which is granted after a notified public hearing, submission and approval of an environmental impact assessment report and an environment management plan.

Our Company must also comply at all times with the provisions of The Hazardous Waste (Management and Handling) Rules, 1989, as amended, and as superseded by the Hazardous Wastes (Management, Handling and Transboundary Movement) Rules, 2008, and the Manufacture, Storage and Import of Hazardous Chemicals Rules, 1989.

#### **1. Environment Protection Act, 1986 and Environment (Protection) Rules, 1986**

The Environmental Protection Act, 1986 is an "umbrella" legislation designed to provide a framework for co-ordination of the activities of various central and state authorities established under various laws. The potential scope of the Act is broad, with "environment" defined to include water, air and land and the interrelationships which exist among water, air and land, and human beings and other living creatures, plants, micro-organisms and property.

#### **2. Water:**

Legislations to control water pollution are listed below:

The *Water (Prevention and Control of Pollution) Act, 1974* prohibits the discharge of pollutants into water bodies beyond a given standard, and lays down penalties for non-compliance. The Water Act also provides that the consent of the State Pollution Control Board must be obtained prior to opening of any new outlets or discharges, which is likely to discharge sewage or effluent.

The *Water (Prevention and Control of Pollution) Cess Act, 1977* provides for the levy and collection of a cess on water consumed by persons carrying on certain industries and by local authorities, with a view to augment the resources of the Central Board and the State Boards for the prevention and control of water pollution constituted under the Water (Prevention and Control of Pollution) Act, 1974.

#### **3. Air:**

Legislations to control air pollution are listed below:

The *Air (Prevention and Control of Pollution) Act, 1981* requires that any individual or institution responsible for emitting smoke or gases by way of use as fuel or chemical reactions must apply in a prescribed form and obtain consent from the state pollution control board prior to commencing any activity. National Ambient Air Quality Standards (NAAQS) for major pollutants were notified by the Central Pollution Control Board in April 1994.

#### **4. Hazardous Wastes:**

There are several legislations that directly or indirectly deal with hazardous wastes. The relevant legislations are:

- The Hazardous Wastes (Management, Handling and Transboundary Movement) Rules, 2008;
- The Public Liability Insurance Act, 1991

#### ***Hazardous Wastes (Management, Handling and Transboundary Movement) Rules, 2008:***

These rules require that the occupier and the operator of the facility, that treats hazardous wastes, must properly collect, treat, store or dispose the hazardous wastes without adverse effects on the environment.

### **D. TAX RELATED LEGISLATIONS:**

#### **1. Income-tax Act, 1961**

The Income-tax Act, 1961 ("**IT Act**") is applicable to every Company, whether domestic or foreign whose income is taxable under the provisions of the IT Act or Rules made thereunder depending upon its "Residential Status" and "Type of Income" involved. The IT Act provides for the taxation of persons resident in India on global income and

persons not resident in India on income received, accruing or arising in India or deemed to have been received, accrued or arising in India. Every Company assessable to income tax under the IT Act is required to comply with the provisions thereof, including those relating to Tax Deduction at Source, Advance Tax, Minimum Alternative Tax and like. Every such Company is also required to file its returns by September 30 of each assessment year.

## **2. Central Goods and Services Tax Act, 2017**

The Central Goods and Services Tax Act, 2017 (“**CGST Act**”) regulates the levy and collection of tax on the intra-State supply of goods and services by the Central Government or State Governments. The CGST Act amalgamates a large number of Central and State taxes into a single tax. The CGST Act mandates every supplier providing the goods or services to be registered within the State or Union Territory it falls under, within 30 days from the day on which he becomes liable for such registration. Such registrations can be amended, as well as cancelled by the proper office on receipt of application by the registered person or his legal heirs. There would be four tax rates namely 5%, 12%, 18% and 28%. The rates of GST applied are subject to variations based on the goods or services.

## **3. Professional Tax**

The professional tax slabs in India are applicable to those citizens of India who are either involved in any profession or trade. The State Government of each State is empowered with the responsibility of structuring as well as formulating the respective professional tax criteria and is also required to collect funds through professional tax. The professional taxes are charged on the incomes of individuals, profits of business or gains in vocations. The professional tax is charged as per the List II of the Constitution. The professional taxes are classified under various tax slabs in India. The tax payable under the State Acts by any person earning a salary or wage shall be deducted by his employer from the salary or wages payable to such person before such salary or wages is paid to him, and such employer shall, irrespective of whether such deduction has been made or not when the salary and wage is paid to such persons, be liable to pay tax on behalf of such person and employer has to obtain the registration from the assessing authority in the prescribed manner. Every person liable to pay tax under these Acts (other than a person earning salary or wages, in respect of whom the tax is payable by the employer), shall obtain a certificate of enrolment from the assessing authority. The following legislation pertaining to Professional Tax is applicable to Company:

Karnataka State Tax on Profession, Trades, Callings and Employments Act, 1976;

## **4. Central Excise Act, 1944**

The Central Excise Act, 1944 (“**Central Excise Act**”) consolidates and amends the law relating to Central Duties of Excise on goods manufactured or produced in India. Excisable goods under the Act means goods specified in the Schedule to the Central Excise Tariff Act, 1985 as being subject to duty of excise. Factory means any premises, including the precincts thereof, wherein or in any part of which excisable goods are manufactured, or wherein or in any part of which any manufacturing process connected with the production of these goods being carried on or is ordinarily carried out. Under the Act a duty of excise is levied on all excisable goods, which are produced or manufactured in India as and at the rates set forth in the First Schedule to the Central Excise Tariff Act, 1985.

## **5. Karnataka Excise Act, 1965**

The Karnataka Excise Act, 1965 relates to the production, manufacture, possession, import, export, transport, purchase and sale of liquor and intoxicating drugs and the levy of duties of excise thereon, in the State of Karnataka. It lays down rules for import, export and transportation of intoxicants, manufacture, possession and sale of excisable items given under the Karnataka Excise Act, 1965 and for establishment of warehouse and distilleries. It also provides for levy of excise duty on the goods listed under the Karnataka Excise Act, 1965 as well as grievance redressal mechanism for any offence mentioned under the Karnataka Excise Act, 1965.

## **E. OTHER LAWS**

### **1. The Karnataka Stamp Act, 1957**

Stamp duty on instruments in the state of Karnataka is governed by the Karnataka Stamp Act. This act levies stamp duty on documents/instruments by which any right or liability is or purports to be created, transferred, limited, extended, extinguished or recorded. All instruments chargeable with duty and executed by any person are required to be stamped before or at the time of execution or immediately thereafter on the next working day following the

day of execution. It authorises the State Government on receiving information from any source, to call for examination of any instrument to satisfy itself that the market value of the property referred therein has been truly set forth and the duty paid on it is adequate. Instruments not duly stamped are incapable of being admitted in court as evidence of the transaction in question. The State Government has the authority to impound insufficiently stamped documents.

## **2. The Indian Stamp Act, 1899**

Under the Indian Stamp Act, 1899, stamp duty is payable on instruments evidencing a transfer or creation or extinguishment of any right, title or interest in immovable property. Stamp duty must be paid on all instruments specified under the Stamp Act at the rates specified in the schedules to the Stamp Act. The applicable rates for stamp duty on instruments chargeable with duty vary from state to state. Instruments chargeable to duty under the Stamp Act, which are not duly stamped are incapable of being admitted in court as evidence of the transaction contained therein and it also provides for impounding of instruments that are not sufficiently stamped or not stamped at all.

## **3. The Registration Act, 1908**

The Registration Act, 1908 has been enacted with the objective of providing public notice of the execution of documents affecting, inter alia, the transfer of interest in immovable property. The purpose of the Registration Act is the conservation of evidence, assurances, title and publication of documents and prevention of fraud. It details the formalities for registering an instrument. Section 17 of the Registration Act identifies documents for which registration is compulsory and includes, among other things, any non-testamentary instrument which purports or operates to create, declare, assign, limit or extinguish, whether in present or in future, any right, title or interest, whether vested or contingent, in any immovable property of the value of one hundred rupees or more, and a lease of immovable property for any term exceeding one year or reserving a yearly rent. A document will not affect the property comprised in it, nor be treated as evidence of any transaction affecting such property (except as evidence of a contract in a suit for specific performance or as evidence of part performance under The Transfer of Property Act 1882 or as collateral), unless it has been registered. Evidence of registration is normally available through an inspection of the relevant land records, which usually contains details of the registered property. Further, registration of a document does not guarantee title of land. Karnataka Registration Rules 1965 have been implemented in the State of Karnataka in order to enforce and carry out the provisions of this Act. 89

## **4. The Indian Contract Act, 1872**

The Indian Contract Act, 1872 (“Contract Act”) codifies the way in which a contract may be entered into, executed, implementation of the provisions of a contract and effects of breach of a contract. A person is free to contract on any terms he chooses. The Contract Act consists of limiting factors subject to which contract may be entered into, executed and the breach enforced. It provides a framework of rules and regulations that govern formation and performance of contract. The contracting parties themselves decide the rights and duties of parties and terms of agreement. The Specific Relief Act, 1963 The Specific Relief Act is complimentary to the provisions of the Contract Act and the Transfer of Property Act, as the Act applies both to movable property and immovable property. The Act applies in cases where the Court can order specific performance of a contract. Specific relief can be granted only for purpose of enforcing individual civil rights and not for the mere purpose of enforcing a civil law. ‘Specific performance’ means Court will order the party to perform his part of agreement, instead of imposing on him any monetary liability to pay damages to other party.

## **5. The Competition Act, 2002**

The Competition Act 2002 (the “Competition Act”) aims to prevent anti-competitive practices that cause or are likely to cause an appreciable adverse effect on competition in the relevant market in India. The Competition Act regulates anti-competitive agreements, abuse of dominant position and combinations. The Competition Commission of India (the “Competition Commission”) which became operational from May 20, 2009 has been established under the Competition Act to deal with inquiries relating to anti-competitive agreements and abuse of dominant position and regulate combinations. The Competition Act also provides that the Competition Commission has the jurisdiction to inquire into and pass orders in relation to an anti-competitive agreement, abuse of dominant position or a combination, which even though entered into, arising or taking place outside India or signed between one or more non-Indian parties, but causes an appreciable adverse effect in the relevant market in India.

## 6. The Companies Act, 1956

The Companies Act, 1956 deals with laws relating to companies and certain other associations. It was enacted by the parliament in 1956. The Act primarily regulates the formation, financing, functioning and winding up of companies. The Companies Act, 1956 prescribes regulatory mechanism regarding all relevant aspects, including organizational, financial and managerial aspects of companies. It deals with issue, allotment and transfer of securities and various aspects relating to company management. It provides for standard of disclosure in public issues of capital, particularly in the fields of company management and projects, information about other listed companies under the same management, and management perception of risk factors. In the functioning of the corporate sector, although freedom of companies is important, protection of the investors and shareholders, on whose funds they flourish, is equally important. The Companies Act, 1956 plays the balancing role between these two competing factors, namely, management autonomy and investor protection.

## 7. The Companies Act, 2013

The Companies Act, 2013 (“Companies Act”), has been introduced to replace the existing Companies Act, 1956 in a phased manner. The Companies Act deals with laws relating to companies and certain other associations. The Companies Act primarily regulates the formation, financing, functioning and winding up of companies. The Companies Act prescribes regulatory mechanism regarding all relevant aspects, including organizational, financial and managerial aspects of companies. It deals with issue, allotment and transfer of securities and various aspects relating to company management. It provides for standard of disclosure in public issues of capital, particularly in the fields of company management and projects, information about other listed companies under the same management, and management perception of risk factors.

## 8. The Trademarks Act, 1999

Under the Trademarks Act, 1999 (“**Trademarks Act**”), a trademark is a mark capable of being represented graphically and which is capable of distinguishing the goods or services of one person from those of others used in relation to goods and services to indicate a connection in the course of trade between the goods and some person having the right as proprietor to use the mark. A ‘mark’ may consist of a device, brand, heading, label, ticket, name signature, word, letter, numeral, shape of goods, packaging or combination of colors or any combination thereof. Section 18 of the Trademarks Act requires that any person claiming to be the proprietor of a trade mark used or proposed to be used by him, must apply for registration in writing to the registrar of trademarks. The trademark, once applied for and which is accepted by the Registrar of Trademarks (“**the Registrar**”), is to be advertised in the trademarks journal by the Registrar. Oppositions, if any, are invited and, after satisfactory adjudications of the same, a certificate of registration is issued by the Registrar. The right to use the mark can be exercised either by the registered proprietor or a registered user. The present term of registration of a trademark is 10 (ten) years, which may be renewed for similar periods on payment of a prescribed renewal fee.

## F. REGULATIONS REGARDING FOREIGN INVESTMENT

Foreign investment in companies in the roadway transport industry is governed by the provisions of the FEMA read with the applicable regulations. The Department of Industrial Policy and Promotion (“**DIPP**”), Ministry of Commerce and Industry has issued ‘Consolidated FDI’ (“**FDI Policy**”) which consolidates the policy framework on Foreign Direct Investment (“**FDI**”), with effect from August 28, 2017. The FDI Circular consolidates and subsumes all the press notes, press releases, and clarifications on FDI issued by DIPP till August 27, 2017. All the press notes, press releases, clarifications on FDI issued by DIPP till August 27, 2017 stand rescinded as on August 28, 2017. Vide an Office Memorandum dated June 5, 2017 (“**Office Memorandum**”), issued by Ministry of Finance, Department of Economic Affairs the Government of India has abolished Foreign Investment Promotion Board (“**FIPB**”).

Foreign investment is permitted (except in the prohibited sectors) in Indian companies either through the automatic route or the approval route, depending upon the sector in which foreign investment is sought to be made. Subsequent to the abolition of FIPB, the work of granting government approval for foreign investment under the FDI Policy and FEMA Regulations has now been entrusted to the concerned Administrative Ministries/Departments. FDI for the items or activities that cannot be brought in under the automatic route may be brought in through the approval route. Where FDI is allowed on an automatic basis without the approval of the Government, the RBI would continue to be the primary agency for the purposes of monitoring and regulating Foreign Investment. In cases where Government approval is obtained, no approval of the RBI is required except

with respect to fixing the issuance price, although a declaration in the prescribed form, detailing the foreign investment, must be filed with the RBI once the foreign investment is made in the Indian company.

The RBI, in exercise of its power under the FEMA, has also notified the Foreign Exchange Management (Transfer or Issue of Security by a Person Resident outside India) Regulations, 2017 to prohibit, restrict or regulate, transfer by or issue security to a person resident outside India. The FDI Policy issued by the DIPP does not prescribe any cap on the foreign investments in the sector in which the Company operates. Therefore, foreign investment up to 100% is permitted in the Company under the automatic route. No approvals of the Administrative Ministries/Departments or the RBI are required for such allotment of equity Shares under this Issue. The Company will be required to make certain filings with the RBI after the completion of the Issue.

## HISTORY AND CERTAIN CORPORATE MATTERS

### Brief History of Our Company

Our Company was incorporated as a public limited company under the Companies Act, 1956 in the name of Vishwanath Sugars Limited vide Certificate of Incorporation dated May 02, 1995 with the Registrar of Companies, Bangalore bearing Registration Number - 017730. Our Company was granted the Certificate of Commencement of Business by the RoC, Bangalore on December 21, 1999. The name of our Company was subsequently changed to Vishwanath Sugar and Steel Limited and a Fresh Certificate of Incorporation dated December 28, 2010 was issued by the Registrar of Companies, Bangalore. The name of our Company was further changed to Vishwaraj Sugar Industries Limited vide Certificate of Incorporation dated November 29, 2012 granted by the Registrar of Companies, Bangalore. The Corporate Identification Number of our Company is U85110KA1995PLC017730.

### Business and Management

For information on our Company's profile, activities, products, services, market segment, growth, technological prowess, managerial expertise, work skill, technical know-how, standing with reference to prominent competitors, major vendors and suppliers, see "Our Business", "Our Management", "Industry Overview", "Management's Discussion and Analysis of Financial Condition and Results of Operations" and "Financial Statements" on page nos. 130, 171, 115, 252 and 202 respectively of this Red Herring Prospectus.

As of the date of this Red Herring Prospectus there are 9,921 Equity shareholders.

### MAJOR EVENTS

Calendar Year	Event
1995	Incorporation of our Company.
1997	Letter of Intent issued by the Government of India.
1999	Grant of Certificate of Commencement of Business.
	Allotment of command area for sugarcane.
	Grant of Distillery License by Government of Karnataka
2000	Land award of 132 acres and 34 gunthas done by Government of Karnataka for the purpose of setting up of sugar factory and staff quarters.
2001	Commencement of commercial operations for our Distillery segment.
2006	Commencement of commercial operations for the Sugar segment and Co-generation segment.
2008	Commencement of commercial operations for the Indian Made Liquor segment.
2009	Commercial operations of enhanced capacity of sugar unit and 2 <sup>nd</sup> unit of co-generation power plant commenced.
	Industrial Entrepreneurs Memorandum approval for increase in production of white sugar to 1,21,000 TPA and a corresponding increase in Molasses to 44,000.
	Manufacturing of Indian Made Liquor brands of our company commenced at Yelahanka, Bangalore
2011	Industrial Entrepreneurs Memorandum approval for increase in production of white sugar to 1,58,400 TPA and a corresponding increase in Molasses to 57,600 TPA.
2012	Industrial Entrepreneurs Memorandum approval for increase in production of white sugar to 2,42,000 TPA and a corresponding increase in Molasses to 88,000 TPA
2015	Cessation of production of Indian Made Liquor at Yelahanka Unit.
2016	Commencement of commercial operations for the Vinegar segment.
2017	Entered into current PPA with Bangalore Electricity Supply Company Limited (BESCOM), Mangalore Electricity Supply Company Limited (MESCOM), Gulbarga Electricity Supply Company Limited (GESCOM), Hubli Electricity Supply Company Limited (HESCOM) and Chamundeshwari Electricity Supply Corporation Limited (CESC, Mysore)
2018	Began construction work for increase in capacity of the Distillery unit from 35 KLPD to 100 KLPD



## MAIN OBJECTS OF OUR COMPANY

The main objects of our Company as contained in our MoA are:

1. *“To purchase, manufacture, produce, boil, prepare, brew, import, export, buy, sell and generally to deal in all varieties of sugar candy, jaggery, khandasari sugar, sugar beet, sugar cane, molasses, syrups, melada, alcohol, spirits and all products and by-products, thereof such as confectionery, glucose, bagasse boards, paper, paper pulp, alcohol, acetone, carbon-dioxide, hydrogen, potash, cane wax, fertilizers, cattle feed and food products generally.*
2. *To plant, cultivate, produce and raise and/or get cultivated through others or purchase sugar cane, sorghum, sugar beet sago, palmyra juice and crops or raw materials used in the production of sugar and its products and by-products.*
3. *To buy, develop, erect, install, engage generators, turbines, apparatus and other equipments to generate electricity for the business of the company using coal, oils, water, any other substances, solar energy, wind energy, atomic energy or any other form of energy, and to buy, distribute and utilize electricity for the aforesaid business or otherwise.”*

The main objects and objects incidental and ancillary to the attainment of the main objects, as contained in the Memorandum of Association, enable our Company to carry on our existing business and the activities for which the working capital is required, which is proposed to be funded from the Net Proceeds. For further details, please refer the chapter “*Objects of the Offer*” on page no. 102 of this Red Herring Prospectus.

## CHANGES IN REGISTERED OFFICE

Except as disclosed below, there has been no change in the Registered Office of Our Company since the date of our Incorporation:

Date of Change	Change of the Registered Office		Reason for Change
	From	To	
April 1, 2001	Vaccine Depot Road, Katti Building, Tilakwadi, Belgaum - 590 006, Karnataka	Bellad Bagewadi, Taluka Hukkeri Bellad Bagewadi - 591 305, Karnataka	Administrative Convenience

## AMENDMENTS TO MEMORANDUM OF ASSOCIATION

Dates on which some of the main clauses of the Memorandum of Association of our Company have been changed citing the details of amendment as under:

Date	Nature of Amendments
December 11, 2000	The initial authorised share capital of ₹ 50,00,000 divided into 5,000 Equity Shares of ₹ 1,000 each was increased to ₹ 10,00,00,000 divided into 1,00,000 Equity Shares of ₹ 1,000 each.
February 15, 2002	The authorised share capital of ₹ 10,00,00,000 divided into 1,00,000 equity shares of ₹ 1,000 each was increased to ₹ 20,00,00,000 divided into 2,00,000 equity shares of ₹ 1,000 each.
January 18, 2003	The authorised share capital of ₹ 20,00,00,000 divided into 2,00,000 equity shares of ₹ 1,000 each was increased to ₹ 30,00,00,000 divided into 3,00,000 equity shares of ₹ 1,000 each.
August 02, 2004	Object Clause III(c) was altered by adding new clause 20 after sub Clause 19 –  20. To promote, run, establish, takeover, or set up mini steel plants, integrated steel plants, composite steel plants, hot rolling steel mills, cold rolling mills, blooms and billet mills, steel furnaces, concasts, rolling mills, induction furnaces, for the manufacturing, producing, converting, extracting, treating, or proceeding of all types grades and sizes of steels, stainless steels, special steels, high speed steels, dies steels electrical steels, forging steels, alloy steels including direct hardening steels, case hardening steels, nit riding steels, ball bearing steels, corrosion resisting steels, heat resisting steels, free cutting steels, spring steels, silico manganese steels, ship building quality steels, armour steels, magnet steels, hot rolled and cold rolled grain oriented electrical steels, structural and torque steels such as hangers, building sections, bridges sections, lock gates, lattice masts, roofs, rollings, beams, pillars, girders, columns, door frames, window frames, purlings, frame works, transmission towers, shutters and other allied items, used in transportation,

Date	Nature of Amendments
	defence public utilities, power stations and lines railways, industries, buildings, tullels, dams, m.s. plates, or any other types of steel, present or future and any products, by products, compounds, and alloys thereof and to act as agent, broker, stockiest trader, buyer, seller, importer, exporter, job worker, or otherwise to deal in all goods materials or things incidental to the attainment of the above objects.
July 05, 2005	The authorised share capital of ₹ 30,00,00,000 divided into 3,00,000 equity shares of ₹ 1,000 each was increased to ₹ 35,00,00,000 divided into 3,50,000 equity shares of ₹ 1,000 each.
May 13, 2010	Split in authorised share capital ₹ 35,00,00,000 divided into 3,50,000 equity shares of ₹ 1,000/- each into 3,50,00,000 equity shares of ₹ 10/- each.
	The authorised share capital of ₹ 35,00,00,000 divided into 3,50,00,000 equity shares of ₹ 10 each was increased to ₹ 50,00,00,000 divided into 5,00,00,000 equity shares of ₹ 10 each
October 19, 2010	Object Clause III(a) was altered by adding Clause 4 to 7 after sub Clause 3 –
	4. To carry on the business of manufacturers of, dealers in, exporters and importers of, all varieties of steel, special steel, mild steel and any other kind and grades of steel and to carry on and execute the work of steel engineers including manufacturing and dealing in steel billets, steel rods, steel ingots, steel sheets, steel wires and all kind of steel products whether forged, rolled or drawn and consequently to manufacture, sell and deal in all or any of the by- products which will be obtained in the process of manufacturing these steel products. To carry on the business of manufacturers, fabricators and dealers of all types of steel, sheet and metal parts, pressure vessels, components, castings, machinery and in particular to undertake fabrication on contract or otherwise of sheet metal parts, pressure vessels, components, castings and machinery.
	5. To carry on the business of miners, importers and exporters of and dealers in iron ores, chromium ores, magnesite ores, thorium, uranium, asbestos, nickel, copper, lead, tin, bauxite ores and all ferrous and non-ferrous ores of every description and grades whatsoever in any part of the world and to carry on the business of processing, cleaning, melting, forging, grading and machining to convert the ores into marketable metals.
	6. To carry on any business relating to the mining and working of minerals, the production and working of metals and the production, manufacture and preparation of any other materials which may be usually or conveniently combined with the engineering or manufacturing business of the Company or any contracts undertaken by the Company, and either for the purpose only of such contracts or as an independent business.
	7. To carry on the business of crushing, winning, getting, quarrying, smelting, calcining, refining, dressing, cutting, polishing and preparing for market, ores, metals, mineral substances, of all kinds of metal and its allied products.
February 15, 2012	Name of the Company is changed to Vishwanath Sugar and Steel Industries Limited vide Certificate of Incorporation dated December 28, 2010.
February 15, 2012	The authorised share capital of ₹ 50,00,00,000 divided into 5,00,00,000 equity shares of ₹ 10 each was increased to ₹ 60,00,00,000 divided into 6,00,00,000 equity shares of ₹ 10 each
September 10, 2012	Name of Company changed to Vishwaraj Sugar Industries Limited vide Certificate of Incorporation dated November 29, 2012.
December 24, 2012	Object Clause III(a) was altered by shifting Clause 4 to 7 to Clause III(c) after existing Clause III(c) sub-clause 19 –
	20. To carry on the business of manufacturers of, dealers in, exporters and importers of, all varieties of steel, special steel, mild steel and any other kind and grades of steel and to carry on and execute the work of steel engineers including manufacturing and dealing in steel billets, steel rods, steel ingots, steel sheets, steel wires and all kind of steel products whether forged, rolled or drawn and consequently to manufacture, sell and deal in all or any of the by- products which will be obtained in the process of manufacturing these steel products. To carry on the business of manufacturers, fabricators and dealers of all types of steel, sheet and metal parts, pressure vessels, components, castings, machinery and in particular to undertake fabrication on contract or otherwise of sheet metal parts, pressure vessels, components, castings and machinery.  21. To carry on the business of miners, importers and exporters of and dealers in iron ores, chromium ores, magnesite ores, thorium, uranium, asbestos, nickel, copper, lead, tin, bauxite ores and all

Date	Nature of Amendments
	<p>ferrous and non-ferrous ores of every description and grades whatsoever in any part of the world and to carry on the business of processing, cleaning, melting, forging, grading and machining to convert the ores into marketable metals.</p> <p>22. To carry on any business relating to the mining and working of minerals, the production and working of metals and the production, manufacture and preparation of any other materials which may be usually or conveniently combined with the engineering or manufacturing business of the Company or any contracts undertaken by the Company, and either for the purpose only of such contracts or as an independent business.</p> <p>23. To carry on the business of crushing, winning, getting, quarrying, smelting, calcining, refining, dressing, cutting, polishing and preparing for market, ores, metals, mineral substances, of all kinds of metal and its allied products.</p>

#### **HOLDING COMPANY**

Our Company does not have a holding company.

#### **OUR SUBSIDIARIES**

As on the date of this Red Herring Prospectus, our Company does not have any subsidiaries.

#### **CHANGES IN THE ACTIVITIES OF OUR COMPANY IN THE LAST FIVE (5) YEARS**

There have been no changes in the activities of our Company during the last five years from the date of this Red Herring Prospectus, which may have had a material effect on our profits or loss.

#### **RAISING OF CAPITAL IN THE FORM OF EQUITY OR DEBT**

Except as disclosed in the chapter titled “*Capital Structure*” on page no. 69 of this Red Herring Prospectus, our Company has not raised any capital in the form of equity or debt.

#### **DEFAULTS OR RESCHEDULING OF BORROWINGS WITH FINANCIAL INSTITUTIONS/ BANKS AND CONVERSION OF LOANS INTO EQUITY**

There have been no defaults or rescheduling or restructuring of borrowings with the financial institutions/ banks. None of our outstanding loans have been converted into Equity Shares.

#### **STRIKE, LOCK-OUTS, ETC.**

There have been no instances of any strikes, lockouts or instances of labour unrest in Our Company.

#### **TIME & COST OVERRUN**

There have been no time/cost overruns pertaining to our business operations.

#### **THE AMOUNT OF ACCUMULATED PROFIT/ (LOSSES) NOT ACCOUNTED FOR BY OUR COMPANY**

Except as stated in “*Risk Factors*” and “*Financial Statements*” on page no. 17 and 202 of this Red Herring Prospectus respectively, there are no accumulated profits or losses that are not accounted for by our Company in the Restated Financial Statements.

#### **REVALUATION OF ASSETS**

Our Company has not revalued its assets since incorporation as on the date of this Red Herring Prospectus.

---

## **INJUNCTIONS OR RESTRAINING ORDER AGAINST OUR COMPANY**

As on the date of this Red Herring Prospectus, there are no injunctions / restraining orders that have been passed against the Company.

## **DETAILS REGARDING ACQUISITION OF BUSINESS/UNDERTAKINGS, MERGERS, AMALGAMATIONS**

Our Company has not acquired any business or undertaking, and has not undertaken any mergers, amalgamation.

## **JOINT VENTURES OF OUR COMPANY**

As on the date of this Red Herring Prospectus, our Company has not entered into any joint venture agreements.

## **STRATEGIC AND FINANCIAL PARTNERSHIPS**

As on the date of this Red Herring Prospectus, our Company does not have any strategic or financial partners.

## **SHAREHOLDER'S AGREEMENTS**

Our Company has not entered into any Shareholder's Agreement or any other Key Agreement as on the date of this Red Herring Prospectus.

## **OTHER AGREEMENTS**

Except the contracts / agreements entered in the ordinary course of the business carried on or intended to be carried on by our Company, we have not entered into any other agreement / contract as on the date of this Red Herring Prospectus.

## OUR MANAGEMENT

### BOARD OF DIRECTORS

In terms of the Articles of Association, our Company is required to have not less than 3 Directors and not more than 15 Directors. As on date of this Red Herring Prospectus, our Board has 10 Directors comprising of one (1) Chairman and Non-Executive Director, four (4) Executive Directors & five (5) Non-Executive Independent Directors.

The following table sets forth details regarding our Board as on the date of this Red Herring Prospectus:

Name, Father's Name, Address, Occupation, Term and DIN	Age	Designation	Other Directorships
<p><b>Mr. Umesh Katti</b> (S/o: Vishwanath Katti)</p> <p><b>Address:</b> 341, Town / Village: Bellad Bagewadi, Taluka Hukkeri, Belgaum – 591 305</p> <p><b>Date of Appointment:</b> May 02, 1995</p> <p><b>Term:</b> Liable to retire by rotation</p> <p><b>Occupation:</b> Agriculturist</p> <p><b>Nationality:</b> Indian</p> <p><b>DIN:</b> 01461050</p>	60 years	Chairman & Non-Executive Director	<ul style="list-style-type: none"> <li>• U R Agrofresh Private Limited</li> <li>• Vishwaraj Infrastructure Private Limited</li> <li>• UK27 Hospitality Services (India)Limited</li> </ul>
<p><b>Mr. Nikhil Katti</b> (S/o: Umesh Katti)</p> <p><b>Address:</b> No. 828, Vaccine Depot Road, Tilakwadi, Belgaum 590006.</p> <p><b>Date of Appointment:</b> April 01, 2016</p> <p><b>Term:</b> For a period of 5 years from April 01, 2016 to March 31, 2021</p> <p><b>Occupation:</b> Business</p> <p><b>Nationality:</b> Indian</p> <p><b>DIN:</b> 02505734</p>	36 years	Managing Director	<ul style="list-style-type: none"> <li>• U R Agrofresh Private Limited</li> <li>• Vishwaraj Infrastructure Private Limited</li> <li>• UK27 Hospitality Services (India)Limited</li> <li>• Shree Hiranyakeshi Sahakari Shakkare Karkhane Niyammit</li> </ul>
<p><b>Mr. Lava Katti</b> (S/o: Ramesh Katti)</p> <p><b>Address:</b> H. No. 341, Katti Oni, Bellad Bagewadi, Belagavi – 591 309</p> <p><b>Date of Appointment:</b> June 30, 2013</p> <p><b>Term:</b> For a period of 3 years from June 30, 2018 to June 29, 2021</p> <p><b>Occupation:</b> Business</p> <p><b>Nationality:</b> Indian</p> <p><b>DIN:</b> 02777164</p>	32 years	Whole – time Director	<ul style="list-style-type: none"> <li>• Vishwaraj Encivil India Private Limited</li> </ul>

Name, Father's Name, Address, Occupation, Term and DIN	Age	Designation	Other Directorships
<p><b>Mr. Kush Katti</b> (S/o: Ramesh Katti)</p> <p><b>Address:</b> H. No. 341, Katti Oni, Bellad Bagewadi, Belagavi – 591 309</p> <p><b>Date of Appointment:</b> June 30, 2013</p> <p><b>Term:</b> For a period of 3 years from June 30, 2018 to June 29, 2021</p> <p><b>Occupation:</b> Business</p> <p><b>Nationality:</b> Indian</p> <p><b>DIN:</b> 02777189</p>	32 years	Whole – time Director	<ul style="list-style-type: none"> <li>• Bellad-Bagewadi Urban Souharda Sahakari Bank</li> <li>• Vishwaraj Encivil India Private Limited</li> </ul>
<p><b>Mr. Mukesh Kumar</b> (S/o: Paras Nath Sharma)</p> <p><b>Address:</b> F-201, Mantri Paradise, Bannerghatta Road, Opp. Reliance Mart, Arekere Gate, Bilekahalli, Bangalore – 560 076</p> <p><b>Date of Appointment:</b> March 01, 2019</p> <p><b>Term:</b> Until the ensuing General Meeting</p> <p><b>Occupation:</b> Service</p> <p><b>Nationality:</b> Indian</p> <p><b>DIN:</b> 02827073</p>	55 years	Whole Time Director (Additional Director)	<ul style="list-style-type: none"> <li>• NIL</li> </ul>
<p><b>Mr. Surendra Khot</b> (S/o: Shantaveer Khot)</p> <p><b>Address:</b> 116, Ramtirth Nagar Belgaum (Kanbargi) Belgaum - 590015</p> <p><b>Date of Appointment:</b> September 22, 2014</p> <p><b>Term:</b> For a period of 5 years from September 22, 2014 to September 21, 2019</p> <p><b>Occupation:</b> Retired</p> <p><b>Nationality:</b> Indian</p> <p><b>DIN:</b> 03504813</p>	74 years	Non-Executive Independent Director	<ul style="list-style-type: none"> <li>• NIL</li> </ul>
<p><b>Mr. Shivanand Tubachi</b> (S/o: Basavanneppa Tubachi)</p> <p><b>Address:</b> Anugraha Plot No. 278, 2<sup>nd</sup> Sector, Shivabasav Nagar, Belgaum – 590 010</p> <p><b>Date of Appointment:</b> September 30, 2017</p> <p><b>Term:</b> For a period of 5 years from</p>	69 years	Non-Executive Independent Director	<ul style="list-style-type: none"> <li>• NIL</li> </ul>



Name, Father's Name, Address, Occupation, Term and DIN	Age	Designation	Other Directorships
<p>September 30, 2017 to September 29, 2022</p> <p><b>Occupation:</b> Service</p> <p><b>Nationality:</b> Indian</p> <p><b>DIN:</b> 07852525</p>			
<p><b>Mr. Basavaraj Hagaragi</b> (S/o: Veerappa Hagaragi)</p> <p><b>Address:</b> House No. 1460/42, Pragati Housing Colony, Bellad Bagewadi, Hukkeri, Belgaum 591305</p> <p><b>Date of Appointment:</b> September 30, 2017</p> <p><b>Term:</b> For a period of 5 years from September 30, 2017 to September 29, 2022</p> <p><b>Occupation:</b> Retired</p> <p><b>Nationality:</b> Indian</p> <p><b>DIN:</b> 07852512</p>	63 years	Non-Executive Independent Director	• NIL
<p><b>Mrs. Pratibha Munnolli</b> (W/o: Pramod Munnolli)</p> <p><b>Address:</b> AT Post, Bellad Bagewadi, Taluka Hukkeri, Belgaum – 591 305</p> <p><b>Date of Appointment:</b> September 30, 2017</p> <p><b>Term:</b> For a period of 5 years from September 30, 2017 to September 29, 2022</p> <p><b>Occupation:</b> Profession</p> <p><b>Nationality:</b> Indian</p> <p><b>DIN:</b> 07852508</p>	34 years	Non-Executive Independent Director	• NIL
<p><b>Mr. R. V. Radhakrishna</b> (S/o: Venkata Subrahmanya Sastry Racharla)</p> <p><b>Address:</b> 7-2-1760/A/104, Aakruti Avenue, St. No.4, Czech Colony, Sanathnagar, Hyderabad, Telangana- 500 018.</p> <p><b>Date of Appointment:</b> December 18, 2017</p> <p><b>Term:</b> For a period of 5 years from December 18, 2017 to December 17, 2022</p> <p><b>Occupation:</b> Service</p> <p><b>Nationality:</b> Indian</p> <p><b>DIN:</b> 00763862</p>	46 years	Non-Executive Independent Director	• Tanvi Foods (India) Limited

For further details on their qualification, experience etc., please see their respective biographies under the heading “*Brief Biographies*” below.

We confirm that the appointment of the above Independent Directors is in compliance with SEBI (LODR) Regulations, 2015, as amended from time to time.

## **BRIEF BIOGRAPHIES OF OUR DIRECTORS**

### **Mr. Umesh Katti**

Mr. Umesh Katti, aged 60 years, is the founding Promoter of our Company. He is designated as Chairman & Non-Executive Director on the Board of the Company. He has done his Pre-University Course from K. L. E. Society’s Lingaraj College, Belgaum. He has over 16 years of experience in the sugar industry. He has been elected as an M.L.A. of the Karnataka Legislature eight times from Hukkeri. He was a Cabinet Minister in the Government of Karnataka between 1996-1999 holding the portfolio of the Sugar Ministry as well as Public Works. He had held various positions in the Government of Karnataka over the years being Minister in Charge of Belgaum District, Minister in charge of Prisons, Horticulture Minister etc. Currently, besides, being a Member of Legislative Assembly, he is also a member of the Committee on Public Undertaking of Karnataka Legislative Assembly. The expertise of Mr. Umesh Katti in the sugar industry as well as in agriculture helps in the formulation of the policies of our Company.

### **Mr. Nikhil Katti**

Mr. Nikhil Katti, aged 36 years, is a Promoter and the Managing Director of our Company. He holds a Bachelor degree of Business Administration from Karnataka University, Dharwad as well as a degree of Masters in Business Administration (MBA) in International Marketing from the University of Wales. He was serving on the Board of our Company since 2009. Having gained over 8 years experience in the sugar industry, he is responsible for the overall growth and development of all our segments especially the distillery unit. He is also involved in the marketing of the products of our Company and has been instrumental in the brand positioning and expansion of our Indian Made Liquor (IML) products. He is also a Member of Zilla Panchayat Ammanagi.

### **Mr. Mukesh Kumar**

Mr. Mukesh Kumar, aged 55 years, has been appointed as an Executive Director of our Company. He has completed his Bachelor of Science (Chemical Engineering) from Ranchi University. He has more than 3 decades of experience in petroleum, distillery and sugar industry including approximately 13 years in our Company from the year 2003 to 2016. He has also acted as a Whole Time Director of our Company from 2009 till 2016 wherein he has been responsible for our Company achieving various milestones. After approximately 3 years, he was recently re-appointed as a Director in our Company to manage various day to day activities.

### **Mr. Lava Katti**

Mr. Lava Katti, aged 32 years, is a Promoter and Whole-time Director of our Company. He holds a Bachelor degree of Business Administration from Karnataka University, Dharwad. He also completed his Master in Business Administration from Cardiff Metropolitan University. He was serving on the Board of our Company since 2013. He has experience in administrating distillery and co-generation units of the Company and also looking after agriculture. He is also part of many social works in this region of Hukkeri Taluka and surrounding villages. He is on the advisory panel of a century old financial institution named Prathamika Krishi Patin Sahakari Sangh Limited, Bellad Bagewadi which caters to the needs of thousands of Farmers. He is serving many social activities through Rahul Katti sports and social club.

### **Mr. Kush Katti**

Mr. Kush Katti, aged 32 years, is a Promoter and Whole-time Director of our Company. He has completed his Master degree in Business Administration from ESC Pau Business School, France. He has been serving on the Board of our Company since 2013 and is instrumental in maintaining cordial relations with farmers and ensuring sugarcane supply to the factory. He is also associated as a Director with Bellad Bagewadi Urban Souhard Bank located in Bellad Bagewadi. He is also part of many social works in this region and takes active part in administrating Shri V. M. Katti Educational Trust, which includes primary, secondary, PU college and ITI colleges. Further, he undertakes many social activities through Rahul Katti Sports and Social Club.

---

**Mr. Surendra Khot**

Mr. Surendra Khot, aged 74 years, is the Non-Executive Independent Director of our Company. He has completed Master degree in Arts from Karnataka University. He was associated with the D.C.C. Bank Limited in Belgaum. He has over 35 years of experience working with the bank as a Deputy General (Banking and Accounts) & General Manager of D.C.C. Bank Limited.

**Mr. Shivanand Tubachi**

Mr. Shivanand Tubachi, aged 69 years, is the Non-Executive Independent Director of our Company. He has completed his Bachelor degree of Arts from Karnataka University. He has over 20 years of experience of working in banking sector. He worked as general manager in the Belgavi District Co-operative Bank Ltd. for 2006 – 2011 and is currently associated with the bank in advisory capacity.

**Mr. Basavaraj Hagaragi**

Mr. Basavaraj Hagaragi, aged 63 years, is the Non-Executive Independent Director of our Company. He has completed his Bachelor degree of Arts from Karnataka University. He has over 20 years of experience in Banking Sector. He has worked in BDCC Bank as Branch Manager, Senior Manager since 1981 and was promoted as General Manager in 2007. He is currently retired.

**Mrs. Pratibha Munnolli**

Mrs. Pratibha Munnolli, aged 34 years, is the Non-Executive Independent Director of our Company. She holds Bachelor degree in Ayurvedic Medicine and Surgery from Rajiv Gandhi University of Health Sciences, Karnataka. She has more than 5 years of experience as medical practitioner.

**Mr. R. V. Radhakrishna**

Mr. R.V. Radhakrishna, aged 46 years, is the Non-Executive Independent Director of our Company. He is an Associate Member of the Institute of Company Secretaries of India. He possesses over 20 years of experience working with various listed and unlisted companies in India. As the Independent Director of our Company he is responsible for providing his expertise & inputs and for ensuring the board adheres to the required corporate governance requirements.

**Confirmations**

None of our Directors is or was a director of any listed companies during the last five years preceding the date of the Draft Red Herring Prospectus, whose shares have been or were suspended from being traded on any Stock Exchange during the term of their directorship in such companies.

None of our Directors is or was a director of any listed companies which have been or were delisted from any stock exchange in India during the term of their directorship in such company.

None of the Directors is categorized as a wilful defaulter, as defined under SEBI (ICDR) Regulations. No proceedings / investigations have been initiated by SEBI against any company, the board of directors of which also comprises any of the Directors of our Company.

None of the Directors have been appointed pursuant to any arrangement or understanding with major shareholders, customers, suppliers or others.

**Relationship between Directors**

None of the Directors of the Company are related to each other except as stated below:

Mr. Umesh Katti is the father of Mr. Nikhil Katti. Mr. Lava Katti and Mr. Kush Katti are Brothers and further are nephew of Mr. Umesh Katti and cousins of Mr. Nikhil Katti.

## Arrangement or Understanding with Major Shareholders, Customers, Suppliers or Others

None of our Directors have been appointed to the Board pursuant to any arrangement or understanding with major Shareholders, customers, suppliers or others.

## Bonus or Profit-Sharing Plan with our Directors

None of the Directors is party to any bonus or profit sharing plan of our Company.

## Loans to Directors

There are no loans that have been availed by our Directors from our Company that are outstanding as on the date of this Red Herring Prospectus.

## Service contracts with Directors

Except for our Managing Director, Mr. Nikhil Katti, no Director has entered into a service contract with our Company pursuant to which they are entitled to any benefits upon termination of employment. Further, the employment agreement dated April 01, 2016 entered into with Mr. Nikhil Katti does not provide any benefit upon termination of their employment from our Company or on their retirement. For further details of the remuneration during their term on our Board, please refer the section “*Remuneration of Executive Directors – Our Management*” on page no. 176 of this Red Herring Prospectus.

## Borrowing Powers of our Board of Directors

Our Company at its Annual General Meeting held on September 30, 2017 passed a resolution authorizing Board of Directors pursuant to the provisions of Section 180 (1) (c) of the Companies Act, 2013 for borrowing from time to time any sum or sums of money from any person(s) or bodies corporate (including holding Company) or any other entity, whether incorporated or not, on such terms and conditions as the Board of Directors may deem fit for the purpose of the Company’s business. The monies so borrowed together with the monies already borrowed by our Company (apart from temporary loans obtained from the banks in the ordinary course of business) may exceed the aggregate of the paid up share capital of our Company and its free reserves, that is to say, reserves not set apart for any specific purpose, provided that the total amount of such borrowings together with the amount already borrowed and outstanding shall not, at any time, exceed ₹ 1,000.00 crores.

## REMUNERATION OF EXECUTIVE DIRECTORS

### Mr. Nikhil Katti (Managing Director)

Pursuant to a resolution passed by the Board of Directors at the meeting held on April 01, 2016 and pursuant to employment agreement dated April 01, 2016 entered between Nikhil Katti and our Company, Nikhil Katti was re – appointed as the Managing Director of our Company for a period of 5 years with effect from April 01, 2016 along with the terms and conditions of his employment as the Managing Director of the Company.

During the tenure Mr. Nikhil Katti will not, directly or indirectly either by himself or through any firm or company or person engage in any business activity similar to that carried on by the Company and/or any of its subsidiaries or affiliates nor engage in any activity that Conflicts with the Nikhil Katti ‘s obligation to the Company, other than on behalf of the Company, whether such engagement is an officer, director, proprietor, employee, partner, agent principal, investor, consultant, advisor agent or otherwise.

<b>Basic Salary</b>	₹ 36,00,000/- per annum
<b>Other Benefits</b>	<ul style="list-style-type: none"> <li>• Reimbursement of reasonable travelling, boarding, lodging and other incidental expenses for attending Board Meetings or the Company’s work outside Bellad Bagewaadi</li> <li>• Entitled to paid vacation each year during the term in addition to public holidays in accordance with the Company’s vacation policies.</li> </ul>

Remuneration paid to him for fiscal 2019 was ₹ 36.00 lakhs.

### Mr. Lava Katti (Whole-time Director)

Pursuant to a resolution passed at the annual general meeting held on September 27, 2018, Mr. Lava Katti was – re-appointed as the Whole-time Director of our Company for a period of 3 years with effect from June 30, 2018 along with the terms of remuneration.

<b>Basic Salary</b>	₹ 24,00,000/- per annum for the financial years 2018-19, 2019-20 and 2020-21
<b>Other Benefits</b>	Nil

Remuneration paid to him for fiscal 2019 was ₹ 24.00 lakhs.

### Mr. Kush Katti (Whole-time Director)

Pursuant to a resolution passed at the annual general meeting held on September 27, 2018, Mr. Kush Katti was – re-appointed as the Whole-time Director of our Company for a period of 3 years with effect from June 30, 2018 along with the terms of remuneration.

<b>Basic Salary</b>	₹ 24,00,000/- per annum for the financial years 2018-19, 2019-20 and 2020-21
<b>Other Benefits</b>	Nil

Remuneration paid to him for fiscal 2019 was ₹ 24.00 lakhs.

### Mr. Mukesh Kumar

Pursuant to Resolution passed by the Board of Directors at the meeting held on February 28, 2019, Mr. Mukesh Kumar was appointed as an Additional (Executive) Director with effect from March 01, 2019 until the ensuing general meeting, along with the terms of remuneration.

<b>Basic Salary</b>	₹ 27,00,000/- per annum for a period of five years from the date of appointment i.e. March 01, 2019
<b>Other Benefits</b>	Nil

Remuneration paid to him for fiscal 2019 was ₹ 2.25 lakhs.

### Compensation of Non-Executive Independent Directors

Pursuant to a resolution passed at the meeting of the Board of the Company on December 18, 2017 the Non-Executive Independent Directors will be paid ₹ 10,000/- per sitting fee for each Board and Audit Committee meetings held.

### Payment or benefit to Directors of Our Company

Except as disclosed in this Red Herring Prospectus, no amount or benefit has been paid or given within the two preceding years or is intended to be paid or given to any of our executive Directors except the normal remuneration for services rendered as a Director of our Company.

### Shareholding of Directors in our Company

Except as disclosed below, none of the Directors hold any Equity Shares in our Company as on the date of filing of this Red Herring Prospectus:

Name of Directors	No. of Equity Shares held	% of Pre-Offer Paid Up Capital
Mr. Umesh Katti	14,18,575	4.11%
Mr. Nikhil Katti <sup>(1)</sup>	36,92,875	10.69%
Mr. Lava Katti <sup>(1)</sup>	12,00,275	3.47%
Mr. Kush Katti <sup>(1)</sup>	12,45,075	3.60%
Mr. Basavaraj Hagaragi	54,900	0.16%

<sup>(1)</sup> Mr. Nikhil Katti, Mr. Lava Katti and Mr. Kush Katti are part of the Selling Shareholders in this Offer

### Appointment of relatives of our Directors to any office or place of profit

Except as mentioned in “*Our Management*” and “*Annexure VI – Note 34 - Related Party Transactions*” on page nos. 171 and 238 respectively of this Red Herring Prospectus, none of the relatives of our Directors currently holds any office or place of profit in our Company.

### Interest of the Directors

All of our Directors may be deemed to be interested to the extent of fees payable to them for attending meetings of the Board or a committee thereof as well as to the extent of other remuneration and reimbursement of expenses payable to them under our Articles of Association, and to the extent of remuneration paid to them of our Company.

Our Directors may also be regarded as interested in the Equity Shares, if any, held by them or allotted to the companies in which they are interested as Directors, Members, and Promoter, pursuant to this Offer. Our Directors may also be deemed to be interested to the extent of any dividend payable to them and other distributions in respect of the said Equity Shares.

Except as stated in this chapter titled “*Our Management*” and the chapter titled “*Annexure VI – Note 34 - Related Party Transactions*” on page nos. 171 and 238 of this Red Herring Prospectus respectively, our Directors do not have any other interest in our business. Further, the purchases made by the Company from the Promoters / Directors as disclosed under “*Annexure VI – Note 34 – Related Party Transactions*” on page no. 238 of this Red Herring Prospectus, pertain to purchase of sugarcane from the agricultural fields owned by such Promoters / Directors.

Except as disclosed in “*Annexure VI – Note 34 - Related Party Transactions*” on page no. 238 of this Red Herring Prospectus, none of the beneficiaries of loans, advances and sundry debtors are related to the Directors of our Company.

Except as disclosed in the section “*Our Business - Properties*” on page no. 151 of this Red Herring Prospectus, our Directors have no interest in any property acquired or proposed to be acquired by our Company within two years of the date of this Red Herring Prospectus. Further, except as disclosed in the section “*Our Business - Properties*” on page no. 151 of this Red Herring Prospectus, our Company has not taken any property on lease from our Promoters and members of Promoter Group within two years of the date of this Red Herring Prospectus.

### Changes in the Board of Directors in the last three years

Sr. No	Name of Director	Date of Change	Reason for change
1	Pratibha Munnolli	September 30, 2017	Appointment as Non-Executive Independent Director
2	Basavaraj Hagaragi	September 30, 2017	Appointment Non-Executive Independent Director
3	Rajaram Shiralkar	November 20, 2017	Resignation Non-Executive Independent Director due to personal reasons
4	Shrinivas Kajoulgi	November 20, 2017	Resignation Non-Executive Independent Director due to personal reasons
5	R. V. Radhakrishna	December 18, 2017	Appointment Non-Executive Independent Director
6	Lava Katti	September 27, 2018	Renewal of term as Whole-time Director
7	Kush Katti	September 27, 2018	Renewal of term as Whole-time Director
8	Mukesh Kumar	March 01, 2019	Appointment as Executive Director (Additional Director)
9	Mallikarjun Pujar	June 01, 2019	Resignation as Whole Time Director due to change in responsibilities and appointment as CAO

### CORPORATE GOVERNANCE

The provisions of the SEBI (LODR) Regulations, 2015 (SEBI Listing Regulations) with respect to corporate governance will be applicable to us immediately upon the listing of our Equity Shares with the Stock Exchanges. We are in compliance with the requirements of the applicable regulations, including the SEBI Listing Regulations, the SEBI Regulations and the Companies Act, in respect of corporate governance including constitution of the Board & committees thereof, preparedness of systems, policies, procedures and manpower. The corporate governance



framework is based on an effective independent Board, separation of the Board's supervisory role from the executive management team and constitution of the Board Committees, as required under law.

Our Board undertakes to take all necessary steps to continue to comply with all the requirements of the SEBI Listing Regulations and the Companies Act. The Board functions either as a full board or through various committees constituted to oversee specific functions. Our executive management provides our Board detailed reports on its performance periodically.

As on the date of this Red Herring Prospectus, our Board has Ten (10) Directors. In compliance with the requirements of the SEBI Listing Regulations and Companies Act we have One (1) Chairman & Non-Executive Director, Four (4) Executive Director and Five (5) Non-Executive Independent Directors on our Board. Our Chairman is Non-Executive Director and we have a woman director on our Board.

## COMMITTEES OF OUR BOARD

In compliance with corporate governance requirements, our Company has constituted the following committees of our Board of Directors for compliance with Corporate Governance requirements:

1. Audit Committee;
2. Stakeholder's Relationship Committee;
3. Nomination and Remuneration Committee; and
4. Corporate Social Responsibility Committee.

### • Audit Committee

The Audit Committee of our Board was re-constituted by our Directors by a board resolution dated December 18, 2017, pursuant to Section 177 of the Companies Act, 2013 and under various regulations of the SEBI Listing Regulations.

The Audit Committee comprises of:

Name of the Member	Nature of Directorship	Designation in Committee
Shivanand Tubachi	Non Executive Independent Director	Chairman
R. V. Radhakrishna	Non Executive Independent Director	Member
Umesh Katti	Chairman & Non-Executive Director	Member

The scope of Audit Committee shall include but shall not be restricted to the following:

- a) Oversight of the Issuer's financial reporting process and the disclosure of its financial information to ensure that the financial statement is correct, sufficient and credible.
- b) Recommending to the Board, the appointment, re-appointment and, if required, the replacement or removal of the statutory auditor and the fixation of audit fees.
- c) Approval of payment to statutory auditors for any other services rendered by the statutory auditors.
- d) Reviewing, with the management, the annual financial statements before submission to the board for approval, with particular reference to:
  - Matters required to be included in the Director's Responsibility Statement to be included in the Board's report in terms of clause (c) of sub-section 3 of Section 134 of the Companies Act, 2013
  - Changes, if any, in accounting policies and practices and reasons for the same
  - Major accounting entries involving estimates based on the exercise of judgment by management
  - Significant adjustments made in the financial statements arising out of audit findings
  - Compliance with listing and other legal requirements relating to financial statements
  - Disclosure of any related party transactions
  - Qualifications in the draft audit report.
- e) Reviewing, with the management, the quarterly financial statements before submission to the board for approval

- f) Reviewing, with the management, the statement of uses / application of funds raised through an Offer (public issue, rights issue, preferential issue, etc.), the statement of funds utilized for purposes other than those stated in the offer document/prospectus/notice and the report submitted by the monitoring agency monitoring the utilization of proceeds of a public or rights issue, and making appropriate recommendations to the Board to take up steps in this matter.
- g) Review and monitor the auditor's independence and performance, and effectiveness of audit process;
- h) Approval or any subsequent modification of transactions of the company with related parties;
- i) Scrutiny of inter-corporate loans and investments;
- j) Valuation of undertakings or assets of the company, wherever it is necessary;
- k) Evaluation of internal financial controls and risk management systems;
- l) Reviewing, with the management, performance of statutory and internal auditors, adequacy of the internal control systems.
- m) Reviewing the adequacy of internal audit function, if any, including the structure of the internal audit department, staffing and seniority of the official heading the department, reporting structure coverage and frequency of internal audit.
- n) Discussion with internal auditors any significant findings and follow up there on.
- o) Reviewing the findings of any internal investigations by the internal auditors into matters where there is suspected fraud or irregularity or a failure of internal control systems of a material nature and reporting the matter to the board.
- p) Discussion with statutory auditors before the audit commences, about the nature and scope of audit as well as post-audit discussion to ascertain any area of concern.
- q) To look into the reasons for substantial defaults in the payment to the depositors, debenture holders, shareholders (in case of non-payment of declared dividends) and creditors.
- r) To review the functioning of the whistle blower mechanism.
- s) Approval of appointment of CFO (i.e., the whole-time Finance Director or any other person heading the finance function or discharging that function) after assessing the qualifications, experience & background, etc. of the candidate.
- t) Carrying out any other function as is mentioned in the terms of reference of the Audit Committee.

Explanation (i): The term "related party transactions" shall have the same meaning as contained in the Accounting Standard 18, Related Party Transactions, issued by The Institute of Chartered Accountants of India.

Explanation (ii): If the Company has set up an audit committee pursuant to provision of the Companies Act, the said audit committee shall have such additional functions / features as is contained in this clause.

*The Audit Committee enjoys following powers:*

- a) To investigate any activity within its terms of reference
- b) To seek information from any employee
- c) To obtain outside legal or other professional advice
- d) To secure attendance of outsiders with relevant expertise if it considers necessary

- e) The audit committee may invite such of the executives, as it considers appropriate (and particularly the head of the finance function) to be present at the meetings of the committee, but on occasions it may also meet without the presence of any executives of the Issuer. The finance director, head of internal audit and a representative of the statutory auditor may be present as invitees for the meetings of the audit committee.

*The Audit Committee shall mandatorily review the following information:*

- a) Management discussion and analysis of financial condition and results of operations;
- b) Statement of significant related party transactions (as defined by the audit committee), submitted by management;
- c) Management letters / letters of internal control weaknesses issued by the statutory auditors;
- d) Internal audit reports relating to internal control weaknesses; and
- e) The appointment, removal and terms of remuneration of the Chief internal auditor shall be subject to review by the Audit Committee.
- f) Statement of deviations:
  - Quarterly statement of deviation(s) including report of monitoring agency, if applicable.
  - Annual statement of funds utilized for purposes other than those stated in the offer document/ prospectus/ notice in terms of Regulation 32(7) of the Listing Regulations.

The recommendations of the Audit Committee on any matter relating to financial management, including the audit report, are binding on the Board. If the Board is not in agreement with the recommendations of the Committee, reasons for disagreement shall have to be incorporated in the minutes of the Board Meeting and the same has to be communicated to the shareholders. The Chairman of the committee has to attend the Annual General Meetings of the Company to provide clarifications on matters relating to the audit.

The Company Secretary of the Company acts as the Secretary to the Committee.

#### *Meeting of Audit Committee*

The audit committee shall meet at least four times in a year and not more than four months shall elapse between two meetings. The quorum shall be either two members or one third of the members of the audit committee whichever is greater, but there shall be a minimum of two independent members present.

#### • **Stakeholder's Relationship Committee**

The Stakeholders' Relationship Committee was re-constituted by our Directors by a board resolution dated December 18, 2017. The scope and function of the Stakeholders' Relationship Committee is in accordance with Section 178 of the Companies Act, 2013 and the SEBI Listing Regulations.

The Stakeholders' Relationship Committee comprises of:

<b>Name of the Member</b>	<b>Nature of Directorship</b>	<b>Designation in Committee</b>
Shivanand Tubachi	Non Executive Independent Director	Chairman
Lava Katti	Whole-time Director	Member
Nikhil Katti	Managing Director	Member

This committee will address all grievances of Shareholders/Investors and its terms of reference include the following:

- a) Allotment and listing of our shares in future
- b) Redressing of shareholders and investor complaints such as non-receipt of declared dividend, annual report, transfer of Equity Shares and issue of duplicate/split/consolidated share certificates;

- c) Monitoring transfers, transmissions, dematerialization, re-materialization, splitting and consolidation of Equity Shares and other securities issued by our Company, including review of cases for refusal of transfer/ transmission of shares and debentures;
- d) Reference to statutory and regulatory authorities regarding investor grievances;
- e) To otherwise ensure proper and timely attendance and redressal of investor queries and grievances;
- f) And to do all such acts, things or deeds as may be necessary or incidental to the exercise of the above powers.
- g) overseeing the performance of the registrars and transfer agents of our Company and to recommend measures for overall improvement in the quality of investor services; and
- h) carrying out such other functions as may be specified by the Board from time to time or specified/provided under the Companies Act, 2013 or SEBI Listing Regulations, or by any other regulatory authority.

The Company Secretary of our Company acts as the Secretary to the Committee.

#### *Quorum and Meetings*

The quorum necessary for a meeting of the Stakeholders Relationship Committee shall be two members or one third of the members, whichever is greater.

- **Nomination and Remuneration Committee**

The Nomination and Remuneration Committee was re-constituted by our Directors by a board resolution dated December 18, 2017. The scope and function of the Nomination and Remuneration Committee is in accordance with Section 178 of the Companies Act, 2013 and under various regulations of the SEBI Listing Regulations.

The Nomination and Remuneration Committee currently comprises of:

<b>Name of the Member</b>	<b>Nature of Directorship</b>	<b>Designation in Committee</b>
Basavaraj Hagaragi	Non Executive Independent Director	Chairperson
Pratibha Munnolli	Non Executive Independent Director	Member
Surendra Khot	Non Executive Independent Director	Member

The scope of Nomination and Remuneration Committee shall include but shall not be restricted to the following:

- a) Formulation of the criteria for determining qualifications, positive attributes and independence of a director and recommend to the Board a policy, relating to the remuneration of the directors, key managerial personnel and other employees;
- b) Formulation of criteria for evaluation of Independent Directors and the Board;
- c) Devising a policy on Board diversity;
- d) Identifying persons who are qualified to become directors and who may be appointed in senior management in accordance with the criteria laid down, and recommend to the Board their appointment and removal. The company shall disclose the remuneration policy and the evaluation criteria in its Annual Report.;
- e) perform such other activities as may be delegated by the Board or specified/ provided under the Companies Act, 2013 or by the SEBI Listing Regulations or by any other regulatory authority.

The Company Secretary of our Company acts as the Secretary to the Committee.

#### *Quorum and Meetings*

The quorum necessary for a meeting of the Nomination and Remuneration Committee shall be two members or one third of the members, whichever is greater. The Committee is required to meet at least once a year.

• **Corporate Social Responsibility Committee**

The Corporate Social Responsibility Committee was re-constituted by our Directors by a board resolution dated December 18, 2017. The scope and function of the Corporate Social Responsibility Committee is in accordance with Section 135 of the Companies Act, 2013.

The Corporate Social Responsibility Committee currently comprises of:

<b>Name of the Member</b>	<b>Nature of Directorship</b>	<b>Designation in Committee</b>
Umesh Katti	Chairman & Non-Executive Director	Chairman
Pratibha Munnolli	Non Executive Independent Director	Member
Kush Katti	Whole-time Director	Member

The terms of reference of the Corporate Social Responsibility Committee of our Company shall include the following:

- a) Formulate and recommend to the Board, a Corporate Social Responsibility Policy which shall indicate the activities to be undertaken by our Company in accordance with the provisions of the Companies Act, 2013;
- b) Review and recommend the amount of expenditure to be incurred on activities to be undertaken by our Company;
- c) Monitor the Corporate Social Responsibility Policy of our Company and its implementation from time to time; and
- d) Any other matter as the Corporate Social Responsibility Committee may deem appropriate after approval of the Board of Directors or as may be directed by the Board of Directors from time to time.

The Company Secretary of our Company acts as the Secretary to the Committee.

**MANAGEMENT ORGANIZATION STRUCTURE**

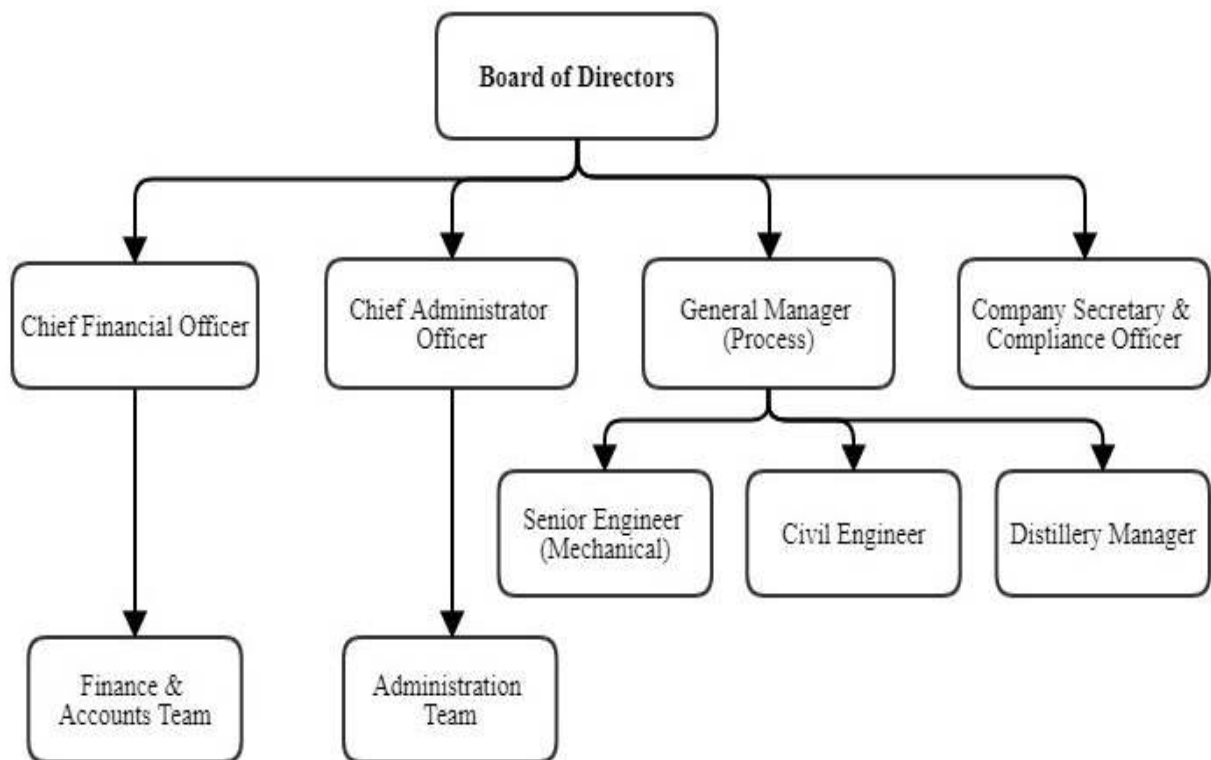



## Key Managerial Personnel

Set forth below are the details of the Key Management Personnel of our Company as of the date of this Red Herring Prospectus:

**Mallikarjun Pujar**, aged 57 years, is the the Chief Administrative Officer (CAO) our Company. He holds a Certificate from the Department of Pre-University Education of the Government of Karnataka. He has over 20 years of experience in the agricultural sector and has knowledge of sugarcane production. He is responsible for liaising with the farmers and for ensuring cordial relations with these farmers. He is currently responsible for handling administration of the office, factory and guest house and also helps in overseeing the crushing activities of sugar unit. He was paid remuneration of ₹ 9.00 lakhs during fiscal 2018-19 (in the capacity of Whole time Director). He was appointed at the current post in our Company from June 01, 2019

**Sheshagiri Kulkarni** aged 40 years, is the Chief Financial Officer of our Company. He has completed his Bachelor degree of Commerce from Karnataka University. He has an overall experience of more than 15 years in the field of accounting, finance and taxation. He has been associated with our company since 2007, where he was initially appointed as Account's Officer and later on he was promoted as Chief Financial Officer w. e. f. May 08, 2014. He was paid remuneration of ₹ 4.71 lakhs during fiscal 2018-19.

**Vinayak Bhosale** aged 55 years, is the General Manager (Process) of our Company. He is a Bachelor of Science (Chemistry) from Shivaji University and has also obtained a post graduate diploma in Sugar Technology from Vasantdada Sugar Institute, Pune. He has total work experience of more than 28 years in companies like Siddeshwar S.S.K Limited, Renuka Sugar, Lokamangal Sugars and Ugar Sugar Works Limited at various positions like Chief Chemist and DGM Process. He was appointed at the current post in our Company from June 28, 2018. He was paid a remuneration of ₹ 8.14 lakhs during the fiscal 2018-19.

**Sunil Arabale** aged 50 years, is the Civil Engineer of our Company. He has completed Diploma Course in Civil Engineering from Latthe Education Society's Polytechnic, Sangli, having experience of over 20 years working as civil engineer. He had earlier worked with Ajit B. Marsute M Arch Arch & Engg. Firm, Jaisingpur, S S Muchandi Engg & Contractors, Kolhapur and Design Colaborative Arch & Engg., Kolhapur. He has been associated with our company since 2006. He was paid remuneration of ₹ 5.94 lakhs during fiscal 2018-19.

**Chanamallaya Hiremath** aged 41 years, is the Senior Engineer (Mechanical) of our company. He has completed his Diploma in Mechanical Engineering from Karnataka. He has also received the Certificate of Proficiency as Boiler Operation Engineer under the Karnataka Boiler Operation Engineer's Rules, 1959. He completed his apprenticeship training from Bharat Electronics, Bangalore. He has total more than 15 years of working experience in the mechanical field & he has previously worked with Benni Engineering Works, Pune. He has been associated with our company since 2005 as Assistant Engineer and later on in 2013 he was promoted as Senior Engineer (Mechanical). He was paid remuneration of ₹ 3.49 lakhs during fiscal 2018-19.

**Vinosali Mullani** aged 42 years, is the Distillery Manager of our Company. He has completed his bachelor degree of Commerce from Karnataka University. He has also completed a certificate course in office automation conducted at N – Technology Computer Education Centre, Gokak. He has been associated with our Company since 1999. He has Vast experience in the field of production work, warehouse work, state excise related work and monitoring all sales and purchases. Further he was promoted as Distillery Manager in 2013. He was paid remuneration of ₹ 2.95 lakhs during fiscal 2018-19.

**Sneha Patil** aged 32 years, is the Company Secretary and Compliance Officer of the Company. She holds Bachelor degree in Commerce from Karnataka University and is a qualified Associate Company Secretary. She has completed her CS training under Mr, Sudheendra Ghali, Practicing Company Secretary & continued there only as Assistant Company Secretary. She joined our company as Company Secretary & Compliance Officer on January 01, 2013. She was paid remuneration of ₹ 4.20 lakhs during fiscal 2018-19.

### **Other Notes –**

The aforementioned KMPs are on the payrolls of our Company as permanent employees.

### Service Contracts

No service contracts have been entered into with any Key Management Personnel for provisions of benefits or payments of any amount upon termination of employment.

### Relationship amongst the Key Managerial Personnel

None of the aforementioned KMP's are related to each other.

Further, there is no arrangement or understanding with the major shareholders, customers, suppliers or others, pursuant to which any Key Management Personnel was selected as member of senior management.

### Bonus or Profit Sharing Plan for the Key Managerial Personnel during the last three years

Our Company does not have fixed bonus / profit sharing plan for any of the employees or key managerial personnel.

### Shareholding of Key Managerial Personnel

As on the date of this Red Herring Prospectus, none of our Key Managerial Personnel hold any Equity shares of our Company, except as stated below;

Name	No. of Equity Shares	% of Pre-Offer Share Capital
Mr. Vinosali Mullani	51,000	0.15%
Mr. Chanamallaya Hiremath	50	Negligible

### Interest of Key Managerial Personnel

The Key Managerial Personnel of our Company do not have any interest in our Company, other than to the extent of remuneration of benefits to which they are entitled as per their terms of appointment and reimbursement of expenses incurred by them during the ordinary course of business. Further, if any Equity Shares are allotted to our Key Managerial Personnel prior to / in terms of this Offer, they will be deemed to be interested to the extent of their shareholding and / or dividends paid or payable on the same.

### Loans taken by Key Management Personnel

Except for Mr. Vinayak Bhonsale who has been given a loan of ₹ 5.00 lakhs in April 2019, none of our Key Managerial Personnel have taken any loan from our Company as on the date of this Red Herring Prospectus.

### Employee Share Purchase and Employee Stock Option Scheme

Presently, we do not have ESOP / ESPS scheme for employees.

### Payment or Benefit to our Officers

Except for the payment of salaries, insurance and yearly bonus, if any, we do not provide any other benefits to our employees.

### Changes in the Key Managerial Personnel in the three years preceding the date of filing this Red Herring Prospectus

Except as disclosed below, there has been no change in KMPs in past three years from the date of this Red Herring Prospectus:

Sr. No.	Name of Employees	Date of Change	Reason for Change
1	Shivanand Katti	December 01, 2016	Termination of Service on account of unsatisfactory performance of his work in the Company
2	Abasaheb Rajaram Patil	December 28, 2016	Resignation on account of personal reasons
3	K. Subramanian	October 04, 2017	Resignation on account of personal reasons
4	Dnyaneshwar Rasal	May 31, 2018	Resignation on account of personal reasons

---

5	Vinayak Bhosale	June 28, 2018	Appointment as General Manager (Process)
6	Vishwanath Hiremath	May 30, 2019	Resignation on account of personal reasons
7	Mallikarjun Pujar	June 01, 2019	Appointment as Chief Administrative Officer (CAO)

## OUR PROMOTERS AND PROMOTER GROUP

### OUR PROMOTERS

Our company is promoted by Mr. Umesh Katti, Mr. Ramesh Katti, Mr. Nikhil Katti, Mrs. Sheela Katti, Mrs. Jayashree Katti, Mr. Lava Katti, Mr. Kush Katti & Mrs. Sneha Nithin Dev.

The details of our individual promoters are as follows:

#### Details of our Promoter

<b>Mr. Umesh Katti</b>	
	<p>Mr. Umesh Katti, aged 60 years, is the founding Promoter of our Company. He is designated as Chairman &amp; Non-Executive Director on the Board of the Company. He has done his Pre-University Course from K. L. E. Society's Lingaraj College, Belgaum. He has over 16 years of experience in the sugar industry. He has been elected as an M.L.A. of the Karnataka Legislature eight times from Hukkeri. He was a Cabinet Minister in the Government of Karnataka between 1996-1999 holding the portfolio of the Sugar Ministry as well as Public Works. He had held various positions in the Government of Karnataka over the years being Minister in Charge of Belgaum District, Minister in charge of Prisons, Horticulture Minister etc. Currently, besides, being a Member of Legislative Assembly, he is also a member of the Committee on Public Undertaking of Karnataka Legislative Assembly. The expertise of Mr. Umesh Katti in the sugar industry as well as in agriculture helps in the formulation of the policies of our Company.</p>
<b>Other Interests</b>	<ul style="list-style-type: none"> <li>➤ U R Agrofresh Private Limited</li> <li>➤ Vishwaraj Infrastructure Private Limited</li> <li>➤ UK27 Hospitality Services (India) Limited</li> </ul>
<b>Voter ID</b>	LJP1950013
<b>Driving License</b>	N. A.
<b>PAN</b>	ABYPK7251L
<b>Passport Number</b>	Z 2249153
<b>Personal Address</b>	341, Town / Village Bellad Bagewadi, Taluka Hukkeri, Belgaum - 591 305
<b>Bank Details</b>	Bank of India, Mukherjee Road, Belgaum A/c No.: 110110110001204

<b>Mr. Ramesh Katti</b>	
	<p>Mr. Ramesh Katti, aged 54 years, is a Promoter of our Company. He is the younger brother of Mr. Umesh Katti. He has over 20 years of experience in the sugar industry. He also has experience in engineering and banking sector having held management positions in various private and co-operative organisations. He is the elected Chairman &amp; Non – Executive Director of The Belagavi District Central Co-operative Bank Limited (BDCC Bank). He has actively participated in the cooperative movement and is a keen social activist as a founder of the Rahul Katti Sports &amp; Social Club. He was the Member of Parliament from the Chikkodi Constituency in the 15<sup>th</sup> Lok Sabha. He has been felicitated with the Bhartiya Udyog Ratna Award by The Indian Economic Development; the Rashtriya Udyog Ratna Award; the Udyog Vikas Ratna Award and other regional and national recognitions.</p>
<b>Other Interests</b>	-
<b>Voter ID</b>	LJP1168814
<b>Driving License</b>	N. A.
<b>PAN</b>	BCOPK4964J
<b>Passport Number</b>	Z 4358935
<b>Personal Address</b>	No. 341, Basav Circle, Bellad Bagewadi, Hukkeri (Rural), Belgaum - 591 305
<b>Bank Details</b>	State Bank of India, S Gokak Road, Sankeshwar A/c No.: 30419062404

<b>Mrs. Sheela Katti</b>	
	Mrs. Sheela Katti, aged 53 years, is one of the Promoters of our Company. She is the wife of our founding Promoter Mr. Umesh Katti. She is currently a home maker and is actively associated with religious and social activities of her community.
<b>Other Interests</b>	-
<b>Voter ID</b>	LJP1950047
<b>Driving License</b>	N. A.
<b>PAN</b>	BBDPK1732N
<b>Passport Number</b>	P 1831465
<b>Personal Address</b>	341, Town / Village BelladBagewadi, Taluka Hukkeri, Belgaum - 591 305
<b>Bank Details</b>	State Bank of India, Shanteri, Belgaum A/c No.: 30419060337

<b>Mrs. Jayashree Katti</b>	
	Mrs. Jayashree Katti, aged 49 years, is one of the Promoters of our Company. She is the wife of our Promoter Mr. Ramesh Katti. She is currently a home maker and is actively associated with religious and social activities of her community.
<b>Other Interests</b>	-
<b>Voter ID</b>	LJP1171735
<b>Driving License</b>	N. A.
<b>PAN</b>	BAJPK3119C
<b>Passport Number</b>	M 3365177
<b>Personal Address</b>	No. 341, Basav Circle, Bellad Bagewadi, Hukkeri (Rural), Belgaum - 591 305
<b>Bank Details</b>	State Bank of India, S Gokak Road, Sankeshwar A/c No.: 30419063407

<b>Mr. Nikhil Katti</b>	
	Mr. Nikhil Katti, aged 36 years, is a Promoter and the Managing Director of our Company. He holds a Bachelor degree of Business Administration from Karnataka University, Dharwad as well as a degree of Masters in Business Administration (MBA) in International Marketing from the University of Wales. He was serving on the Board of our Company since 2009. Having gained over 8 years experience in the sugar industry, he is responsible for the overall growth and development of all our segments especially the distillery unit. He is also involved in the marketing of the products of our Company and has been instrumental in the brand positioning and expansion of our Indian Made Liquor (IML) products. He is also a Member of Zilla Panchayat Ammanagi.
<b>Other Interests</b>	<ul style="list-style-type: none"> <li>➤ U R Agrofresh Private Limited</li> <li>➤ Vishwaraj Infrastructure Private Limited</li> <li>➤ UK27 Hospitality Services (India) Limited</li> <li>➤ Shree Hiranyakeshi Sahakari Shakkare Karkhane Niyammit</li> </ul>
<b>Voter ID</b>	XYF2414936

<b>Driving License</b>	KA22-20060006518
<b>PAN</b>	ANCPK9007C
<b>Passport Number</b>	R 2128923
<b>Personal Address</b>	No. 828, Vaccine Depot Road, Tilakwadi, Belgaum – 590 006.
<b>Bank Details</b>	ICICI Bank, Khanapur Road, Belgaum A/c No.: 017601525537

<b>Mr. Lava Katti</b>	
	Mr. Lava Katti, aged 32 years, is a Promoter and Whole-time Director of our Company. He holds a Bachelor degree of Business Administration from Karnataka University, Dharwad. He also completed his Master in Business Administration from Cardiff Metropolitan University. He was serving on the Board of our Company since 2013. He has experience in administrating distillery and co-generation units of the Company and also looking after agriculture. He is also part of many social works in this region of Hukkeri Taluka and surrounding villages. He is on the advisory panel of a century old financial institution named Prathamika Krishi Patin Sahakari Sangh Limited, Bellad Bagewadi which caters to the needs of thousands of Farmers. He is serving many social activities through Rahul Katti Sports and Social Club.
<b>Other Interests</b>	➤ Vishwaraj Encivil India Private Limited
<b>Voter ID</b>	XYF0555367
<b>Driving License</b>	KA49 20090012860
<b>PAN</b>	AZTPK3776B
<b>Passport Number</b>	P 8156920
<b>Personal Address</b>	H. No. 341, Katti Oni, Bellad Bagewadi, Belgaum – 591 309
<b>Bank Details</b>	State Bank of India, S Gokak Road, Sankeshwar A/c No.: 30385430055

<b>Mr. Kush Katti</b>	
	Mr. Kush Katti, aged 32 years, is a Promoter and Whole-time Director of our Company. He has completed his Master degree in Business Administration from ESC Pau Business School, France. He has been serving on the Board of our Company since 2013 and is instrumental in maintaining cordial relations with farmers and ensuring sugarcane supply to the factory. He is also associated as a Director with Bellad Bagewadi Urban Souhard Bank located in Bellad Bagewadi. He is also part of many social works in this region and takes active part in administrating Shri V. M. Katti Educational Trust, which includes primary, secondary, PU college and ITI colleges. Further, he undertakes many social activities through Rahul Katti Sports and Social Club.
<b>Other Interests</b>	➤ Bellad-Bagewadi Urban Souharda Sahakari Bank ➤ Vishwaraj Encivil India Private Limited
<b>Voter ID</b>	XYF0555359
<b>Driving License</b>	KA49 20090012859
<b>PAN</b>	AZTPK3775C
<b>Passport Number</b>	M 9193192
<b>Personal Address</b>	Sneh, Bellad Bagewadi, Belgaum – 591 305
<b>Bank Details</b>	Axis Bank, Belgavi A/c No.: 911010053017594



<b>Mrs. Sneha Nithin Dev</b>	
	Sneha Nithin Dev, aged 33 years, is the Promoter of our Company. She is the daughter of our Promoter Mr. Umesh Katti. She is currently a home maker and is actively associated with social activities of her community.
<b>Other Interests</b>	-
<b>Voter ID</b>	XYF0168088
<b>Driving License</b>	KA22 20060004050
<b>PAN</b>	AQOPK2775Q
<b>Passport Number</b>	J 2384050
<b>Personal Address</b>	M 104, Bridge Gate Way, 26/1, Dr. Raj Kumar Road, Malleshwaram Bangaluru, Karnataka – 560 055
<b>Bank Details</b>	Bank of India, Mukherjee Road, Belgaum A/c No.: 110110110029793

Our Company confirms that the Permanent Account Number, Bank Account Number and passport number of our Promoters have been submitted to the Stock Exchanges at the time of filing the Draft Red Herring Prospectus.

Our Promoters and their relatives have not been declared as wilful defaulters by any bank or financial institution or consortium thereof, in accordance with the guidelines on wilful defaulters issued by the RBI or any other government authority. Further, there are no violations of securities laws committed by our Promoters and members of the Promoter Group in the past and no proceedings for violation of securities laws are pending against them.

Our Promoters and members of the Promoter Group have not been prohibited from accessing or operating in capital markets under any order or direction passed by SEBI, or any other regulatory or governmental authority.

#### **Interest of our Promoter**

None of our Promoters have any interest in our Company except to the extent of compensation payable / paid, reimbursement of expenses (if applicable), other related party transaction as disclosed under “Annexure VI – Note 34 – Related Party Transactions” on page no. 238 of this Red Herring Prospectus and to the extent of any equity shares held by them or their relatives and associates or held by the companies, firms and trusts in which they are interested as director, member, partner, and / or trustee, and to the extent of benefits arising out of such shareholding. For further details please refer the chapters titled “Capital Structure”, “Financial Information” and “Our Management” beginning on page nos. 69, 202 and 171 of this Red Herring Prospectus.

Except as stated otherwise in this Red Herring Prospectus, we have not entered into any contract, agreements or arrangements in which our Promoters are directly or indirectly interested and no payments have been made to them in respect of the contracts, agreements or arrangements which are proposed to be made with them including the properties purchased by our Company other than in the normal course of business.

#### *Interest in promotion of our Company*

Our Promoters are interested in our Company to the extent that they have promoted our Company and to the extent of their shareholding and the dividend payable, if any and other distributions in respect of the Equity Shares held by them. For details on shareholding of our Promoters in our Company, see the sections “Capital Structure” and “Our Management” on page nos. 69 and 171 respectively of this Red Herring Prospectus.

Further, our Promoters who are also the Directors of our Company may be deemed to be interested to the extent of fees, if any, payable to them for attending meetings of the Board or a Committee thereof as well as to the extent of other remuneration, reimbursement of expenses payable to them for services rendered to our Company in accordance with the provisions of the Companies Act, 2013 (to the extent notified), terms of the Articles of Association and their terms

of appointment. For further details see chapter titled “*Our Management*” on page no. 171 of this Red Herring Prospectus.

Our Promoters may also be deemed to be interested in the transactions entered into by our Company and the ventures where he/she is interested as a Promoter, Director or otherwise. For details of such transactions, please refer to “*Annexure VI – Note 34 – Related Party Transactions*” on page no. 238 of this Red Herring Prospectus.

#### *Interest in the properties of our Company*

Our Promoters have no interest in any property acquired by our Company within two years of the date of the Draft Red Herring Prospectus.

#### *Interest as members of our Company*

Our Promoters are interested to the extent of their shareholding and the dividend declared in relation to such respective shareholding, if any, by our Company. For further details in this regard, please refer chapter titled “*Capital Structure*” on page no. 69 of this Red Herring Prospectus.

Except as stated otherwise in this Red Herring Prospectus, we have not entered into any contract, agreements or arrangements in which our Promoters are directly or indirectly interested and no payments have been made to them in respect of the contracts, agreements or arrangements which are proposed to be made with them including the properties purchased by our Company other than in the normal course of business.

#### **Other Interest**

Our Promoters are not interested in any transaction in acquisition of land or property, construction of building and supply of machinery, or any other contract, agreement or arrangement entered into by the Company and no payments have been made or are proposed to be made in respect of these contracts, agreements or arrangements.

#### **Common Pursuits of our Promoters**

We are primarily in the business of manufacture of sugar and ancillary products. There are no common pursuits amongst our Promoters and us in relation to the same.

However, our Managing Director and Promoter, Mr. Nikhil Katti is an elected non-executive director in a co-op sugar unit, Shree Hiranyakeshi Sahakari Shakkare Karkhane Niyammit. He has no managerial control or any pecuniary interest or controlling interest in the said co-op sugar unit. His association is only honorary in nature due to his status as an active politician in this region. Hence, this has not been considered for conflict of interest.

#### **Companies with which our Promoters have disassociated in the last three years**

Our Promoters have not disassociated themselves from any of the companies, firms or entities during the last three years preceding the date of this Red Herring Prospectus.

#### **Payment of benefits to our Promoters and Promoter Group during the last two years**

Except as stated in the chapter “*Our Management*” on page no. 171 of this Red Herring Prospectus and in “*Annexure VI – Note 34 - Related Party Transactions*” on page no. 238 of this Red Herring Prospectus, there has been no other payment of benefits given to our Promoters in the two years preceding the date of this Red Herring Prospectus.

#### **Change in Management and control of our Company**

There has been no change in management and control of our Company.

#### **Related Party Transactions**

Except as stated in the chapter “*Annexure VI – Note 34 - Related Party Transactions*” on page no. 238 of this Red Herring Prospectus, our Company is not involved in any related party transaction with our Promoters.

## OUR PROMOTER GROUP

In addition to our Promoter, the following individuals, companies, partnerships and HUFs form part of our Promoter Group in terms of SEBI ICDR Regulation 2(1) (zb) of the SEBI ICDR Regulations:

*Individuals forming part of the Promoter Group as per Regulation 2(1)(zb)(ii):*

### Mr. Umesh Katti

Name of the Person	Relationship with the Promoter
Vishwanath Katti (Late)	Father
Rajeshwari Katti (Late)	Mother
Sheela Katti	Spouse
Ramesh Katti	Brother(s)
Purnima Annappa Pangi Harsha Satish Kanavi	Sister(s)
Nikhil Katti	Son(s)
Sneha Nithin Dev	Daughter(s)
Mahaningappa Babanna Ghuli (Late)	Spouse's Father
Annapurna Mahaningappa Ghuli	Spouse's Mother
Satish M Ghuli Suhas M Ghuli	Spouse's Brother(s)
Geeta Honnalli Drakshayani Ravindra Katti	Spouse's Sister(s)

### Mr. Ramesh Katti

Name of the Person	Relationship with the Promoter
Vishwanath Katti (Late)	Father
Rajeshwari Katti (Late)	Mother
Jayashree Katti	Spouse
Umesh Katti	Brother(s)
Purnima Annappa Pangi Harsha Satish Kanavi	Sister(s)
Lava Katti Kush Katti	Son(s)
N. A.	Daughter(s)
Jagannath Chunamari (Late)	Spouse's Father
Channavva Chunamari	Spouse's Mother
Yuvaraj Chunamari Shanmukappa Chunamari	Spouse's Brother(s)
Kalavati Dundappa Savadakar Shailaja Shivaprasad Uchale Kanchan Deepak Prasade Shreya Abinash Pattanashetti	Spouse's Sister(s)

### Mrs. Sheela Katti

Name of the Person	Relationship with the Promoter
Mahaningappa Babanna Ghuli (Late)	Father
Annapurna Mahaningappa Ghuli	Mother
Umesh Katti	Spouse
Satish M Ghuli Suhas M Ghuli	Brother(s)
Geeta Honnalli Drakshayani Ravindra Katti	Sister(s)
Nikhil Katti	Son(s)
Sneha Nithin Dev	Daughter(s)
Vishwanath Katti (Late)	Spouse's Father

Rajeshwari Katti (Late)	Spouse's Mother
Ramesh Katti	Spouse's Brother(s)
Purnima Annappa Pangi Harsha Satish Kanavi	Spouse's Sister(s)

### Mrs. Jayashree Katti

Name of the Person	Relationship with the Promoter
Jagannath Chunamari (Late)	Father
Channavva Chunamari	Mother
Ramesh Katti	Spouse
Yuvaraj Chunamari Shanmukappa Chunamari	Brother(s)
Kalavati Dundappa Savadakar Shailaja Shivaprasad Uchale Kanchan Deepak Prasade Shreya Abinash Pattanashetti	Sister(s)
Lava Katti Kush Katti	Son(s)
N. A.	Daughter(s)
Vishwanath Katti (Late)	Spouse's Father
Rajeshwari Katti (Late)	Spouse's Mother
Umesh Katti	Spouse's Brother(s)
Purnima Annappa Pangi Harsha Satish Kanavi	Spouse's Sister(s)

### Mr. Nikhil Katti

Name of the Person	Relationship with the Promoter
Umesh Katti	Father
Sheela Katti	Mother
Shruti Katti	Spouse
N. A.	Brother(s)
Sneha Nithin Dev	Sister(s)
Aryan Katti	Son(s)
Araina Katti	Daughter(s)
Subhas C. Marihal	Spouse's Father
Lilavati Subhas Marihal	Spouse's Mother
Sachin Subhas Marihal	Spouse's Brother(s)
N. A.	Spouse's Sister(s)

### Mr. Lava Katti

Name of the Person	Relationship with the Promoter
Ramesh Katti	Father
Jayashree Katti	Mother
Ashwini Katti	Spouse
Kush Katti	Brother(s)
N. A.	Sister(s)
N. A.	Son(s)
Gouri Katti Shambhavi Katti	Daughter(s)
Ashok Pattanashetti	Spouse's Father
Sunita Ashok Pattanashetti	Spouse's Mother
Aditya Ashok Pattanashetti	Spouse's Brother(s)
N. A.	Spouse's Sister(s)

**Mr. Kush Katti**

Name of the Person	Relationship with the Promoter
Ramesh Katti	Father
Jayashree Katti	Mother
Akshata Katti	Spouse
Lava Katti	Brother(s)
N. A.	Sister(s)
Arush Katti	Son(s)
N. A.	Daughter(s)
Chandragouda Patil	Spouse's Father
Nanda Chandragouda Patil	Spouse's Mother
Arun Chandragouda Patil	Spouse's Brother(s)
N.A	Spouse's Sister(s)

**Mrs. Sneha Nithin Dev**

Name of the Person	Relationship with the Promoter
Umesh Katti	Father
Sheela Katti	Mother
Nithin Prabhudev	Spouse
Nikhil Katti	Brother(s)
N. A.	Sister(s)
Aarav Nithindev Ayaansh Nithindev	Son(s)
N.A	Daughter(s)
Nanjundappa Prabhudev	Spouse's Father
Rajeswari Prabhudev	Spouse's Mother
Ajith Prabhudev	Spouse's Brother(s)
N.A	Spouse's Sister(s)

***Companies, partnerships and HUFs forming part of the Promoter Group as per Regulation 2(1)(zb)(iv):***
***Companies***

- UK27 Hospitality Services (India) Limited
- Vishwaraj Infrastructure Private Limited
- U R Agro Fresh Private Limited
- Vishwaraj Encivil India Private Limited

***HUFs***

- Umesh Vishwanath Katti HUF
- Ramesh Vishwanath Katti HUF

***Firms***

- Vishwaraj Developers (Partnership Firm)

***Trusts***

- VSL Shareholders Welfare Trust

**Individuals / Persons forming part of Promoter Group as per Regulation 2(1)(zb)(v)**

Ashok Utture	Abhinandan Khempapure
Kashinath Utture	Rajaram Shiralkar

Kadayya Pujar	Basavraj Utture
Basavaraj Pujar	Gurappa Katti
Ramappa Khemlapure	Vinod Katti
Ramesh Shiralakar	Padmaja Katti
Sudhir Katti	Pallavi Ghuli
Ramappa Bani	Tejasvini Chunamuri
Ravindra Katti	Prachi Ghuli
Muragesh Katti	Sanjay Khemalapur
Kallapa Bani	Sudharshan Khemalapur

### Other Confirmations

None of our Promoters or Promoter Group has been declared as willful defaulter by the RBI or any other governmental authority and there are no violations of securities laws committed by them in the past or are currently pending against them.

Further, none of our Promoters or members of our Promoter Group or any company of which they are promoter, directors or persons in control have been debarred, or restricted from accessing the capital markets for any reasons, by SEBI or any other authorities.



## OUR GROUP COMPANIES

In terms of the SEBI ICDR Regulations, for the purposes of identification of group companies for disclosure in connection with the Offer, our Company has considered companies which are included in the list of related parties in our Restated Financial Statements (“Relevant Period”) in accordance with applicable accounting standards, i.e., Indian Accounting Standard 24 notified under the Companies (Indian Accounting Standards) Rule, 2015 (“Ind AS 24”) and such other companies considered material by our Board.

Pursuant to a Board resolution dated December 18, 2017, the Board formulated a policy with respect to companies which it considered material to be identified as group companies. Our Board has approved that all companies which are identified as related parties in accordance with Ind As 24 (erstwhile Accounting Standards 18) as per the Restated Financial Statements and Companies considered by the board as material, are identified as group entities.

Accordingly, the following companies have been identified as a Group Company.

- I. U R Agrofresh Private Limited
- II. UK27 Hospitality Services Private Limited
- III. Vishwaraj Infrastructure Private Limited

Unless otherwise specifically stated, none of our Group Companies described below (i) are listed on any stock exchange; (ii) have completed any public or rights issue since the date of its incorporation; (iii) have become a sick company within the meaning of SICA; (iv) are under winding-up; (v) have become defunct; (vi) have made an application to the relevant registrar of companies in whose jurisdiction such Group Company is registered in the five years preceding the date of filing the Draft Red Herring Prospectus with SEBI, for striking off its name; (vii) have received any significant notes on the financial statements from the auditors; (viii) are prohibited from accessing the capital markets for any reasons by the SEBI or any other authorities; (ix) identified as wilful defaulter as defined under the SEBI ICDR Regulations; (x) involved in any economic offences; or (xi) defaults in meeting any statutory/bank/institutional due; or (xii) had negative net worth as of the date of their last audited financial statements.

### I. U R AGROFRESH PRIVATE LIMITED (“URAPL”)

<b>Incorporation</b>	U R Agrofresh Private Limited was incorporated as U R Steel and Cement Private Limited on December 30, 2009 under the Companies Act, 1956 with the Registrar of Companies, Bangalore, in the State of Karnataka. The name of the Company was changed when we got new Certificate of Incorporation on 25 <sup>th</sup> May 2010.
<b>CIN</b>	U15490KA2009PTC051995
<b>Registered Office</b>	"Sneh", Bellad Bagewadi Hukkeri Belgaum – 591 305
<b>Nature of Business</b>	U R Agrofresh Private Limited is engaged in the agro-business; from planting to packing and selling to reprocessing of all kinds of vegetables, fruits, food grains, cereals, herbs, aromatic grass, plants, tree crops, its residue and extracts and seeds of all other description. Manufacturers, processors, producers, dealers, traders, importers, exporters, sellers, consultants, researchers and developers of all or any sort of agro and biotech and related products and fields. It is also engaged in the business of tissue culture, agriculture, horticulture, pisciculture and sericulture and grow and trade in seeds, vegetables, flowers, herbs, saplings, fruits, plants, trees, crops, grass and its residue, extracts, essences and natural products of any kind.
<b>Registrar of Companies</b>	‘E’ Wing, 2 <sup>nd</sup> Floor, Kendriya Sadan, Bangalore – 560 034.

### Board of Directors of URAPL

Sr. No.	Name
1.	Mr. Umesh Katti
2.	Mr. Nikhil Katti
3.	Mr. Nithin Prabhudev

### Interest of our Promoter

Our Promoters & Promoter Group hold 100.00% equity shares of this company.

### Brief Audited Financials of URAPL

(₹ in lakhs)

Particulars	As at March 31,		
	2018	2017	2016
Equity Share Capital (F. V. ₹ 100/-)	261.00	261.00	261.00
Reserves (excluding revaluation reserve) and Surplus <sup>(1)</sup>	5.56	(9.96)	(13.99)
Sales	1,287.41	736.89	-
Profit/ (Loss) after tax	15.52	4.03	(13.99)
Earnings per share <sup>(2)</sup>	5.95	1.50	Negative
Net asset value per share <sup>(3)</sup> (F. V. ₹ 100/-)	102.13	96.18	94.64

<sup>(1)</sup> Excluding preliminary expenses not written off

<sup>(2)</sup> EPS is calculated on PAT minus Preference Dividend and Tax thereon, if any

<sup>(3)</sup> NAV per share does not include Preference Share Capital and Share Application Money, if any

## II. UK27 HOSPITALITY SERVICES (INDIA) LIMITED (“UK27”)

<b>Incorporation</b>	UK27 Hospitality Services (India) Limited was incorporated as UK27 Hospitality Services (India) Private Limited on August 02, 2013 under the Companies Act, 1956 with the Registrar of Companies, Bangalore, in the State of Karnataka. The name of the Company was changed consequent to change in status of company from private limited to public limited on 05 <sup>th</sup> May 2016.
<b>CIN</b>	U55101KA2013PLC070433
<b>Registered Office</b>	CTS No. 8692/A, Sect No-3, Shivabasav Nagar, Belgaum Karnataka 590010.
<b>Nature of Business</b>	UK27 Hospitality Services (India) Limited was incorporated with the object to carry out business of hospitality services in India and Abroad and of establishing and running of hotels, restaurants, cafes, yoga centres, banquet halls, art galleries, sport entertainment, health club and the like. However, the company has not yet commenced its commercial operations.
<b>Registrar of Companies</b>	‘E’ Wing, 2 <sup>nd</sup> Floor, Kendriya Sadan, Bangalore – 560 034.

### Board of Directors of UK27

Sr. No.	Name
1.	Mr. Umesh Katti
2.	Mr. Nikhil Katti
3.	Mr. Ramappa Khemalapure
4.	Mr. Rajendra Sansuddi

### Interest of our promoter

Our promoters and promoters group hold 99.17% equity shares of this company.

### Brief Audited Financials of UK27 Hospitality Services (India) Limited

(₹ in lakhs)

Particulars	As at March 31,		
	2018	2017	2016
Equity Share Capital	1,341.34	1,341.34	600.00
Reserves (excluding revaluation reserve) and Surplus <sup>(1)</sup>	(781.36)	(159.86)	(116.70)
Sales (including Other Income)	-	2.18	-
Profit/ (Loss) after tax	-	-	-
Earnings per share <sup>(2)</sup>	-	-	-
Net asset value per share <sup>(3)</sup>	4.17	8.81	8.06

<sup>(1)</sup> Excluding preliminary expenses not written off

<sup>(2)</sup> EPS is calculated on PAT minus Preference Dividend and Tax thereon, if any

<sup>(3)</sup> NAV per share does not include Preference Share Capital and Share Application Money, if any

### III. VISHWARAJ INFRASTRUCTURE PRIVATE LIMITED (“VIPL”)

<b>Incorporation</b>	Vishwaraj Infrastructure Private Limited was incorporated as Vishwaraj Power Private Limited on November 11, 2009 under the Companies Act, 1956 with the Registrar of Companies, Bangalore, in the State of Karnataka. The name of the Company was changed to Vishwaraj Infrastructure Private Limited on 03 <sup>rd</sup> August 2010.
<b>CIN</b>	U45400KA2009PTC051441
<b>Registered Office</b>	‘Sneh’ Bellad Bagewadi, Hukkeri, Belgaum – 591 305
<b>Nature of Business</b>	Vishwaraj Infrastructure Private Limited is engaged establishment, growth, developing Special Economic Zone. However, the company has not yet commenced its commercial operations.
<b>Registrar of Companies</b>	‘E’ Wing, 2 <sup>nd</sup> Floor, Kendriya Sadan, Bangalore – 560 034.

#### Board of Directors

Sr. No.	Name
1.	Mr. Umesh Katti
2.	Mr. Nikhil Katti

#### Interest of our promoter

Our promoters and promoters group hold 98.00% equity shares of this company.

#### Brief Audited Financials of VIPL

(₹ in lakhs)

Particulars	As at March 31,		
	2018	2017	2016
Equity Share Capital (F. V. ₹ 100/-)	10.00	10.00	10.00
Reserves (excluding revaluation reserve) and Surplus <sup>(1)</sup>	318.80	467.35	(39.19)
Sales	-	-	-
Profit/ (Loss) after tax	-	-	-
Earnings per share <sup>(2)</sup>	-	-	-
Net asset value per share <sup>(3)</sup> (F. V. ₹ 100/-)	3,287.99	4,773.50	(291.90)

<sup>(1)</sup> Excluding preliminary expenses not written off

<sup>(2)</sup> EPS is calculated on PAT minus Preference Dividend and Tax thereon, if any

<sup>(3)</sup> NAV per share does not include Preference Share Capital and Share Application Money, if any

#### NATURE AND EXTENT OF INTEREST OF OUR GROUP COMPANIES

##### a. Interest in our Company

Our Group Companies have no interest in the promotion of the Company. Further, except as otherwise stated, our Group Companies have no interest including any business interest in our Company. For further details, please see “Annexure VI – Note 34 - Related Party Transaction” and “Capital Structure” on page nos. 238 and 69 of this Red Herring Prospectus, respectively.

##### a. Interest in the Properties acquired or proposed to be acquired by our Company

Our Group Companies have no interest in any property acquired by our Company in the two years preceding the filing of this Red Herring Prospectus or proposed to be acquired by the Company as of the date of this Red Herring Prospectus.

##### b. Interest in transactions for acquisition of land, construction of building and supply of machinery

Except as stated in “Annexure VI – Note 34 - Related Party Transactions” on page no. 238 of this Red Herring Prospectus, our Group Companies have no interest in the transactions for acquisition of land, construction of building and supply of machinery or any other contracts, agreements or arrangements entered into by our Company

---

and no payments have been made or are proposed to be made in respect of these contracts, agreements or arrangements by our Company to its Group Companies.

**Common Pursuits between the Company and its Group Companies**

Our Group Companies do not have any common pursuits with our Company.

**Related business transactions within the Group Companies and significance on the financial performance of the Company**

Except as disclosed in “*Related Party Transactions*” on page no. 238 of this Red Herring Prospectus, there are no related business transactions of the Company with its Group Companies. For details on the significance of related party transactions on the financial performance of the Company, please see “*Our Business*” and “*Management’s Discussion and Analysis of Financial Condition and Results of Operations*” on page nos. 130 and 252, respectively.

**Sale/Purchase between our Company and its Group Companies**

Our Group Companies are not involved in any sales or purchases with our Company where such sales or purchases exceed, in the aggregate, 10% of the total sales or purchases of our Company for the financial year 2019.

## DIVIDEND POLICY

Under the Companies Act, 2013, our Company can pay dividends upon a recommendation by our Board of Directors and approval by a majority of the shareholders at the General Meeting. The shareholders of our Company have the right to decrease, not to increase the amount of dividend recommended by the Board of Directors. The dividends may be paid out of profits of our Company in the year in which the dividend is declared or out of the undistributed profits or reserves of previous fiscal years or out of both. The Articles of Association of our Company also gives the discretion to our Board of Directors to declare and pay interim dividends.

In accordance with Ind AS, our Company has declared dividend in the financial years 2014-15 and 2015-16, details of which are as below:

(₹ in lakhs)

Particulars	For the year ended March 31,				
	2019	2018	2017	2016	2015
Equity Share Capital	3,455.60	3,455.60	3,455.60	3,455.60	3,455.60
Face Value of Equity Shares (₹ per share)	10.00	10.00	10.00	10.00	10.00
Interim Dividend	Nil	Nil	Nil	345.56	Nil
Final Dividend	Nil	Nil	Nil	Nil	345.56
<b>Total Dividend</b>	<b>Nil</b>	<b>Nil</b>	<b>Nil</b>	<b>345.56</b>	<b>345.56</b>
Total Dividend Tax	Nil	Nil	Nil	71.31	56.06
Rate of Dividend (%)	Nil	Nil	Nil	10%	10%
Total Dividend (₹ per share)	Nil	Nil	Nil	1.00	1.00

Our dividend payments and policy in the past is not necessarily indicative of our dividend policy or dividend amounts in the future.

The declaration and payment of dividend will be recommended by our Board of Directors and approved by the shareholders of our Company at their discretion and will depend on a number of factors, including the results of operations, earnings, capital requirements and surplus, general financial conditions, applicable Indian legal restrictions and other factors considered relevant by our Board of Directors.

## SECTION VI – FINANCIAL INFORMATION

### FINANCIAL STATEMENTS

#### REPORT OF THE AUDITORS ON FINANCIAL STATEMENTS

To,  
The Board of Directors,  
**Vishwaraj Sugar Industries Limited,**  
Bellad Bagewadi, Taluka Hukkeri,  
District Belgaum – 591 305  
Karnataka, India

Independent Auditors' Report on Restated Indian Accounting Standards ("Ind AS") Financial Information in connection with the proposed Initial Public Offer (IPO) of the equity shares of face value of ₹ 10 each of Vishwaraj Sugar Industries Limited (the 'Company')

Dear Sirs,

1. We have examined the attached Restated Financial Information of Vishwaraj Sugar Industries Limited (the "Company") which comprise the Restated Statement of Assets and Liabilities as at March 31, 2019, March 31, 2018, March 31, 2017, March 31, 2016 and March 31, 2015, the Restated Statement of Profit and Loss (including Other Comprehensive Income), the Restated Statement of Cash Flows and the Restated Statement of Changes in Equity for the years ended March 31, 2019, March 31, 2018, March 31, 2017, March 31, 2016 and March 31, 2015 and the Statement of Notes to the Restated Financial Statements along with significant accounting policies and other explanatory information (collectively the "Restated Financial Information") as approved by the Board of Directors at their meeting held on July 08, 2019, for the purpose of inclusion in the Red Herring Prospectus / Prospectus prepared by the Company in terms of the requirements of:
  - a) Section 26 of Part I of Chapter III of the Companies Act, 2013, as amended (the "Act")
  - b) The Securities and Exchange Board of India (Issue of Capital and Disclosure Requirements) Regulations, 2009, as amended in pursuance of provisions of Securities and Exchange Board of India Act, 1992 ("ICDR Regulations") and the related clarifications issued by the Securities and Exchange Board of India ('SEBI'); as amended to date;
  - c) The Guidance Note on Reports in Company Prospectuses (Revised 2019) issued by the Institute of Chartered Accountants of India ("ICAI"), as amended from time to time (the "Guidance Note").
2. The preparation of the Restated Financial Information is the responsibility of the management of the Company for the purpose set out in paragraph 12 below. The management's responsibility includes designing, implementing and maintaining adequate internal control relevant to the preparation and presentation of the Restated Financial Information. The management is also responsible for identifying and ensuring that the Company complies with the Act and ICDR Regulations.
3. We have examined such Restated Financial Information taking into consideration:
  - a) The terms of reference and terms of our engagement agreed upon with you in accordance with our engagement letter dated May 24, 2019 in connection with the proposed IPO; and
  - b) The Guidance Note on Reports in Company Prospectuses (Revised 2019) issued by the Institute of Chartered Accountants of India (the "ICAI"), as amended from time to time (the "Guidance Note").
4. These Restated Financial Information have been compiled by the management of the Company from:
  - a) The audited financial statements as at and for the year ended March 31, 2019 and March 31, 2018, prepared in accordance with the Indian Accounting Standard (Indian Accounting Standards) prescribed under Section 133 of the Companies Act, 2013 read with Companies (Indian Accounting Standards) Rules, 2015 (as amended), and other relevant provisions of the Act, and on which we have expressed an unmodified audit opinion, which have been approved by the Board of Directors.



- b) The audited financial statements as at and for the year ended March 31, 2017, March 31, 2016 and March 31, 2015, prepared in accordance with Companies (Accounting Standards) Rules, 2006, as amended, other accounting principles generally accepted in India (“Previous GAAP” or “IGAAP”) and the other relevant provisions of the Act, which have been approved by the Board of Directors.
- c) The information has been extracted from the financial statements audited by M/s. P. G. Ghali & Co., Chartered Accountants, for the F. Y. 2016-17, F. Y. 2015-16 and F. Y. 2014-15, being the Statutory Auditors of the Company for the respective years. The adjustments related to transition to Ind AS from the audited financial statements as at and for the year ended March 31, 2017, March 31, 2016 and March 31, 2015 have been audited by us. These audited financial statements have been adjusted for the differences in the accounting principles adopted by the Company on transition to Ind AS.
- d) The Restated Financial Information as at and for the years ended March 31, 2017, March 31, 2016 and March 31, 2015 is referred to as “the Proforma Ind AS Restated Financial Information” as per the Guidance Note.
5. In accordance with the requirements of Section 26 of Part I of Chapter III of the Companies Act, 2013 (“the Act”) read with ICDR Regulations and the Guidance Note, we report that:
- a) The Restated Statement of Assets and Liabilities of the Company as at March 31, 2019, March 31, 2018, March 31, 2017, March 31, 2016 and March 31, 2015 examined by us, as set out in **Annexure I** to this report, have been arrived at after making adjustments and regrouping/ reclassifications as in our opinion were appropriate and more fully described in the statement of Significant Accounting Policies and the Notes to Restated Financial Information in **Annexure V** and **Annexure VI** respectively read along with Statement of First Time Adoption of Ind AS and Adjustments to Audited Financial Statements in **Annexure VII**.
- b) The Restated Statement of Profit and Loss (including Other Comprehensive Income) of the Company, for the years ended March 31, 2019, March 31, 2018, March 31, 2017, March 31, 2016 and March 31, 2015 examined by us, as set out in **Annexure II** to this report, have been arrived at after making adjustments and regrouping/ reclassifications as in our opinion were appropriate and more fully described in the statement of significant accounting policies and the Notes to Restated Financial Information in **Annexure V** and **Annexure VI** respectively read along with Statement of First Time Adoption of Ind AS and Adjustments to the Audited Financial Statements in **Annexure VII**;
- c) The Restated Statement of Cash Flows of the Company, for the years ended March 31, 2019, March 31, 2018, March 31, 2017, March 31, 2016 and March 31, 2015 examined by us, as set out in **Annexure III** to this report, have been arrived at after making adjustments and regrouping/ reclassifications as in our opinion were appropriate and more fully described in the statement of significant accounting policies and the Notes to Restated Financial Information in **Annexure V** and **Annexure VI** respectively read along with Statement of First Time Adoption of Ind AS and Adjustments to the Audited Financial Statements in **Annexure VII**; and
- d) The Restated Statement of Statement of Changes in Equity of the Company, for the years ended March 31, 2019, March 31, 2018, March 31, 2017, March 31, 2016 and March 31, 2015 examined by us, as set out in **Annexure IV** to this report, have been arrived at after making adjustments and regrouping / reclassifications as in our opinion were appropriate and more fully described in Notes to the Restated Financial Information in **Annexure VI** read along with Statement of First Time Adoption of Ind AS and Adjustments to the Audited Financial Statements in **Annexure VII**.
- e) There were no auditor qualifications and / or emphasis of matter on the Financial Statements in the Auditors Report for the years ended March 31, 2019, March 31, 2018, March 31, 2017, March 31, 2016 and March 31, 2015.
6. Based on the above and according to the information and explanations given to us, and also based on the reliance placed on the financial statements, audited by the previous auditor, M/s. P. G. Ghali & Co., Chartered Accountants, for the years ended March 31, 2017, March 31, 2016 and March 31, 2015, and their audit reports which have been furnished to us by the Company, we further report that the Restated Financial Information:
- i) have been made after incorporating adjustments for the changes in accounting policies retrospectively in respective financial years to reflect the same accounting treatment as per changed accounting policy for all the reporting periods;

- ii) have been made after incorporating adjustments for the material amounts in the respective financial years to which they relate;
  - iii) do not contain any extraordinary items that need to be disclosed separately and do not contain any qualification requiring adjustments;
  - iv) have been made after incorporating adjustments for prior period and other material amount in the respective financial years to which they relate; and
  - v) do not require any corrective adjustments on account of other remarks/ comments in the Companies (Auditor's Report) Order, 2016 ("the Order"), as amended, issued by the Central Government of India in terms of sub-section (11) of section 143 of the act, on financial statements of the Company for the financial years ended March 31, 2017, 2016 and 2015, which are stated in the Notes to Accounts as set out in **Annexure VI: Statement of Notes to the Restated Financial Information** read alongwith **Annexure VII: Statement of First Time Adoption of Ind AS and Adjustments to the Audited Financial Statements**.
7. We have also examined the following Restated Financial Information of the Company set out in the Annexures prepared by the Management and approved by the Board of Directors for the years ended March 31, 2019, March 31, 2018, March 31, 2017, March 31, 2016 and March 31, 2015. In respect of the years ended March 31, 2017, March 31, 2016 and March 31, 2015, our examination was based upon the financial statements audited and reported by the previous auditor, M/s. P. G. Ghali & Co., Chartered Accountants, and relied upon by us.
- a) Annexure V: Restated Statement of Significant Accounting Policies;
  - b) Annexure VI: Notes to Restated Financial Statements
  - c) Annexure VII: Statement of First Time Adoption of Ind AS and Adjustments to the Audited Financial Statements; and
  - d) Annexure VIII: Statement of Tax Shelter

According to the information and explanations given to us, and also as per the reliance placed on the reports issued by the previous auditor, M/s. P. G. Ghali & Co., Chartered Accountants, the Restated Financial Information of the Company as at and for the years ended March 31, 2019, March 31, 2018, March 31, 2017, March 31, 2016 and March 31, 2015, including the above mentioned Restated Financial Information contained in **Annexures I to V** are prepared after making adjustments and regrouping / reclassifications as considered appropriate and have been prepared in accordance with Section 26 of Part I of Chapter III of the Act, the ICDR Regulations and the Guidance Note.

8. At the request of the company, we have also examined the financial information ("Other Financial Information") proposed to be included in the Red Herring Prospectus / Prospectus, prepared by the management and approved by the board of directors of the company and annexed to this report.
9. In our opinion, the Restated Financial Statements and the other Financial Information set forth in **Annexure I to VII** have been prepared in accordance with Section 26 of Companies Act, 2013 and the SEBI Regulations and the Guidance Note on the reports in Company Prospectus (Revised) issued by the Institute of Chartered Accountants of India (ICAI).

Consequently, the financial information has been prepared after making such regroupings and adjustments as were, in our opinion, considered appropriate to comply with the same. As a result of these regrouping and adjustments, the amount reported in the financial information may not necessarily be the same as those appearing in the respective audited financial statements for the relevant years.

10. This report should not in any way be construed as a reissuance or re-dating of any of the previous audit reports issued by us and the previous auditor, M/s. P. G. Ghali & Co., Chartered Accountants, nor should this report be construed as a new opinion on any of the audited financial statements referred to herein.
11. We have no responsibility to update our report for events and circumstances occurring after the date of the report.

- 
12. Our report is intended solely for use of management for inclusion in the Offer Document to be filed with Securities and Exchange Board of India, the Stock Exchanges where the equity shares are proposed to be listed and the Registrar of Companies, Bangalore in connection with the proposed issue of equity shares of the Company. Our report should not be used, referred to or distributed for any other purpose except with our prior consent in writing.

For and on behalf of

**For Gojanur & Co.**  
**Chartered Accountants**  
**FRN: 000941S**

**G. M. Channappa Shetty**  
**Proprietor**  
**M. No. 020227**

Place: Bellad Bagewadi  
Date: July 08, 2019  
UDIN: 19020227AAAAAZ1545

---

**Vishwaraj Sugar Industries Limited****INDEX**

<b>Sr. No.</b>	<b>Details of Restated Financial Information</b>	<b>Annexure Reference</b>
1	Restated Statement of Assets and Liabilities	I
2	Restated Statement of Profit and Loss	II
3	Restated Statement of Cash Flows	III
4	Restated Statement of Changes in Equity	IV
5	Restated Statement of Significant Accounting Policies	V
6	Statement of Notes to the Restated Financial Information	VI
7	Statement of First Time Adoption of Ind AS and Adjustments to Audited Financial Statements	VII
8	Statement of Tax Shelter	VIII

**RESTATED STATEMENT OF ASSETS AND LIABILITIES**  
(Amounts in ₹ lakhs, unless otherwise stated)

**Annexure I**

Particulars	Note No.	As at March 31,				
		2019	2018	2017 (Proforma)	2016 (Proforma)	2015 (Proforma)
<b>ASSETS</b>						
<b>NON-CURRENT ASSETS</b>						
Property, Plant and Equipments	2	26,440.54	27,188.80	24,069.44	24,413.23	24,598.79
Capital Work-in-Progress	2	1,126.02	-	3,834.55	128.82	508.21
Intangible Assets		-	-	-	-	-
Financial Assets:						
i. Investments	3	108.24	53.24	37.98	37.65	37.65
ii. Other financial assets	4	214.60	213.45	262.89	263.18	265.18
Deferred Tax Assets (Net)		-	-	-	-	-
Other Non-Current Assets		-	-	-	-	-
<b>Total Non – Current Assets</b>		<b>27,889.40</b>	<b>27,455.49</b>	<b>28,204.86</b>	<b>24,842.88</b>	<b>25,409.83</b>
<b>CURRENT ASSETS</b>						
Inventories	5	32,434.62	26,157.20	18,199.84	24,446.57	26,953.98
Financial assets:						
i. Trade Receivables	6	3,835.87	3,388.06	4,435.39	1,857.18	1,249.79
ii. Cash & Cash Equivalents	7	169.35	671.02	1,242.07	5,135.81	1,977.55
iii. Bank Balances other than ii above.	8	15.00	74.70	31.58	29.13	14.88
iv. Others financial assets	9	4.47	4.61	15.52	44.64	0.22
Current Tax Assets (Net)		-	-	-	-	-
Other Current Assets	10	7,606.26	4,667.56	2,190.73	2,542.33	4,894.96
<b>Total Current Assets</b>		<b>44,053.93</b>	<b>34,963.14</b>	<b>26,115.13</b>	<b>34,055.65</b>	<b>35,091.37</b>
<b>TOTAL ASSETS</b>		<b>71,954.96</b>	<b>62,418.63</b>	<b>54,319.99</b>	<b>58,898.53</b>	<b>60,501.20</b>
<b>EQUITY AND LIABILITIES</b>						
<b>Shareholder's Funds</b>						
Equity Share Capital	11	3,455.60	3,455.60	3,455.60	3,455.60	3,455.60
Other Equity	12	17,694.09	19,432.35	19,793.19	19,153.66	19,533.82
<b>Total Equity</b>		<b>21,149.69</b>	<b>22,887.95</b>	<b>23,248.79</b>	<b>22,609.26</b>	<b>22,989.42</b>
<b>Non-Current Liabilities</b>						
Financial Liabilities:						
i. Borrowings	13	6,541.43	3,700.79	999.46	2,076.77	3,402.04
Provisions	14	182.65	167.96	209.72	211.65	116.58
Deferred Tax Liabilities(Net)	15	765.21	1,391.94	1,057.56	841.63	354.70
<b>Total Non-Current Liabilities</b>		<b>7,489.29</b>	<b>5,260.69</b>	<b>2,266.75</b>	<b>3,130.06</b>	<b>3,873.33</b>
<b>Current Liabilities</b>						
Financial Liabilities:						

i. Borrowings	16	25,385.68	26,467.77	21,666.16	22,647.16	19,433.79
ii. Trade Payables	17	11,271.89	2,686.39	1,434.36	2,694.25	5,561.88
iii. Other Financial Liabilities	18	3,716.34	2,417.46	2,046.84	4,353.25	3,914.01
Other Current Liabilities	19	2,931.57	2,664.44	3,412.73	3,309.29	4,717.90
Provisions	20	10.49	12.36	12.17	114.79	6.76
Current Tax Liabilities (Net)	21	-	21.58	232.18	143.00	4.13
<b>Total Current Liabilities</b>		<b>43,315.97</b>	<b>34,269.99</b>	<b>28,804.45</b>	<b>33,159.21</b>	<b>33,638.46</b>
<b>TOTAL LIABILITIES</b>		<b>71,954.96</b>	<b>62,418.63</b>	<b>54,319.99</b>	<b>58,898.53</b>	<b>60,501.20</b>

The above statement should be read with the Basis of Preparation - Significant Accounting Policies and Statement On First Time Adoption of Ind AS and Adjustments to Audited Financial Statements appearing in Annexure V and Annexure VII of Restated Financial Information, respectively.

As per our report of even date attached

**For Gojanur & Co.**  
**Chartered Accountants**  
**FRN: 000941S**

**For and on behalf of the Board of Directors of**  
**Vishwaraj Sugar Industries Limited**

**G. M. Channappa Shetty**  
**Proprietor**  
**M. No. 020227**

**Nikhil Katti**  
**Managing Director**

**Mukesh Kumar**  
**Director**

**Sheshagiri Kulkarni**  
**Chief Financial Officer**

**Sneha Patil**  
**Company Secretary**

Place: Bellad Bagewadi  
Date: July 08, 2019

Place: Bellad Bagewadi  
Date: July 08, 2019



**RESTATED STATEMENT OF PROFIT AND LOSS ACCOUNT**  
(Amounts in ₹ lakhs, unless otherwise stated)

**Annexure II**

Particulars	Note No.	For the year ended March 31,				
		2019	2018	2017 (Proforma)	2016 (Proforma)	2015 (Proforma)
<b>INCOME</b>						
Revenue from Operations (inclusive of excise duty)	22	30,679.58	25,928.30	32,184.21	40,575.83	34,508.36
Other Income	23	107.97	964.80	103.91	288.73	428.02
<b>Total Income</b>		<b>30,787.55</b>	<b>26,893.11</b>	<b>32,289.84</b>	<b>40,864.55</b>	<b>34,936.75</b>
<b>EXPENDITURE</b>						
Cost of Materials Consumed	24	27,665.37	22,695.78	12,819.41	22,928.76	23,239.60
Change in Inventories of Finished goods, Work-in-progress	25	(6,280.27)	(7,894.47)	6,292.78	2,535.09	(2,323.23)
Other Manufacturing Expenses	26	2,058.96	2,425.34	2,375.51	2,455.17	2,298.66
Excise Duty		2,044.29	3,746.95	3,782.47	7,011.17	6,883.51
Employee Benefit Expenses	27	1,303.28	1,242.97	1,361.77	1,215.76	1,190.65
Finance Costs	28	3,635.69	2,085.05	2,491.41	1,787.34	1,608.98
Depreciation & Amortisation	2	1,334.28	1,319.96	1,153.47	1,133.96	1,011.33
Other Expenses	29	1,414.66	1,357.72	965.95	1,069.57	1,039.63
<b>Total Expenses :</b>		<b>33,176.27</b>	<b>26,979.30</b>	<b>31,242.78</b>	<b>40,136.83</b>	<b>34,949.14</b>
<b>Profit / (Loss) Before Tax</b>		<b>(2,388.72)</b>	<b>(86.20)</b>	<b>1,045.34</b>	<b>727.73</b>	<b>(12.77)</b>
Tax Expenses:						
- Current Tax		-	6.08	223.16	155.45	6.36
- Deferred Tax Charge/(Credit)		(626.72)	334.38	215.93	486.93	38.57
<b>Total Tax Expenses</b>		<b>(626.72)</b>	<b>340.47</b>	<b>439.09</b>	<b>642.38</b>	<b>44.92</b>
<b>Profit / (Loss) After Tax</b>		<b>(1,761.99)</b>	<b>(426.67)</b>	<b>606.25</b>	<b>85.35</b>	<b>(57.68)</b>
<b>Other Comprehensive Income</b>						
i. Items that will not be reclassified to Profit or loss		23.74	81.32	42.31	(61.10)	(11.72)
ii. Income tax relating to items that will not be reclassified to Profit or loss		-	(15.50)	(9.03)	12.46	2.23
<b>Total Comprehensive Income</b>		<b>(1,738.26)</b>	<b>(360.85)</b>	<b>639.53</b>	<b>36.71</b>	<b>(67.17)</b>
<b>Earnings Per Share (in ₹)</b>						
<b>Basic and Diluted</b>	31	(5.10)	(1.23)	1.75	0.25	(0.17)

The above statement should be read with the Basis of Preparation - Significant Accounting Policies and Statement On First Time Adoption of Ind AS and Adjustments to Audited Financial Statements appearing in Annexure V and Annexure VII of Restated Financial Information, respectively.

As per our report of even date attached

**For Gojanur & Co.  
Chartered Accountants  
FRN: 000941S**

**For and on behalf of the Board of Directors of  
Vishwaraj Sugar Industries Limited**

**G. M. Channappa Shetty  
Proprietor  
M. No. 020227**

**Nikhil Katti  
Managing Director**

**Mukesh Kumar  
Director**

**Sheshagiri Kulkarni  
Chief Financial Officer**

**Sneha Patil  
Company Secretary**

Place: Bellad Bagewadi  
Date: July 08, 2019

Place: Bellad Bagewadi  
Date: July 08, 2019

**RESTATED STATEMENT OF CASH FLOWS**  
(Amounts in ₹ lakhs, unless otherwise stated)

**Annexure III**

Particulars	For the year ended March 31,				
	2019	2018	2017 (Proforma)	2016 (Proforma)	2015 (Proforma)
<b>Cash flow from operating activities:</b>					
Net Profit before tax	(2,388.72)	(86.20)	1,045.34	727.73	(12.77)
Adjusted for:					
Depreciation & Amortisation	1,334.28	1,319.96	1,153.47	1,133.96	1,011.33
Dividend	(3.41)	(3.40)	(4.30)	(0.02)	(0.03)
Profit/ (Loss) on sale of assets	83.72	5.03	4.79	8.33	5.16
Interest & Financial Charges	3,635.69	2,085.05	2,491.41	1,787.34	1,608.98
<b>Operating Profit Before Working Capital Changes</b>	<b>2,661.56</b>	<b>3,320.44</b>	<b>4,690.71</b>	<b>3,657.34</b>	<b>2,612.68</b>
Adjusted for (Increase)/ Decrease in:					
Trade Receivables	(447.81)	1,047.34	(2,578.21)	(607.39)	2,812.74
Inventories	(6,277.42)	(7,957.36)	6,246.73	2,507.41	(2,451.75)
Other Current Assets	(2,938.70)	(2,476.83)	351.59	2,352.63	(464.72)
Other Financial Assets	(1.01)	60.36	29.41	(42.43)	0.48
Trade Payables	8,585.51	1,252.03	(1,259.89)	(2,867.63)	(1,660.58)
Provisions	36.56	39.75	40.27	39.49	21.76
Other Financial Liabilities	642.04	235.08	(1,311.09)	(626.04)	575.23
Other Current Liabilities	267.13	(748.30)	103.45	(1,408.61)	1,570.34
<b>Cash Generated From Operations Before Extra-Ordinary Items</b>	<b>2,527.85</b>	<b>(5,227.49)</b>	<b>6,312.96</b>	<b>3,004.77</b>	<b>3,016.18</b>
<b>Cash Generated From Operations</b>	<b>2,527.85</b>	<b>(5,227.49)</b>	<b>6,312.96</b>	<b>3,004.77</b>	<b>3,016.18</b>
Direct Tax Paid	21.58	232.18	143.00	4.13	462.67
<b>Net Cash Flow from/(used in) Operating Activities: (A)</b>	<b>2,506.27</b>	<b>(5,459.67)</b>	<b>6,169.97</b>	<b>3,000.65</b>	<b>2,553.52</b>
<b>Cash Flow From Investing Activities:</b>					
Purchase of Fixed Assets (Including CWIP)	(1,916.59)	(612.49)	(4,542.07)	(581.60)	(4,966.02)
Sale of Fixed Assets	120.83	2.68	21.88	4.26	1.83
Investment in Shares	(55.00)	(15.26)	(0.33)	-	(27.50)
Dividend Received	3.41	3.40	4.30	0.02	0.03
<b>Net Cash Flow from/(used in) Investing Activities: (B)</b>	<b>(1,847.34)</b>	<b>(621.67)</b>	<b>(4,516.22)</b>	<b>(577.33)</b>	<b>(4,991.65)</b>
<b>Cash Flow from Financing Activities:</b>					
Increase / (Decrease) in Long Term Borrowing	3,497.48	2,836.87	(1,970.11)	(362.50)	1,367.33
Increase / (Decrease) in Short Term Borrowing	(1,082.09)	4,801.61	(981.00)	3,213.37	3,989.56
Interest & Financial Charges	(3,635.69)	(2,085.05)	(2,491.41)	(1,787.34)	(1,608.98)
Dividend and Dividend Distribution Tax Paid	-	-	(102.52)	(314.35)	(401.62)
<b>Net Cash Flow from/(used in) Financing Activities (C)</b>	<b>(1,220.30)</b>	<b>5,553.43</b>	<b>(5,545.03)</b>	<b>749.19</b>	<b>3,346.29</b>
<b>Net Increase/(Decrease) in Cash &amp; Cash Equivalents (A+B+C)</b>	<b>(561.37)</b>	<b>(527.91)</b>	<b>(3,891.29)</b>	<b>3,172.50</b>	<b>908.16</b>
<b>Cash &amp; Cash Equivalents As At Beginning of the Year</b>	<b>745.72</b>	<b>1,273.65</b>	<b>5,164.93</b>	<b>1,992.43</b>	<b>1,084.27</b>
<b>Cash &amp; Cash Equivalents As At end of the Year</b>	<b>184.35</b>	<b>745.73</b>	<b>1,273.64</b>	<b>5,164.93</b>	<b>1,992.43</b>

1. The Restated Statement of Cash Flows has been prepared under the indirect method as set out in 7, Statement of Cash Flows. Effective 01 April 2017, the Company adopted the amendment to 7, which require the entities to provide disclosures that enable users of financial statements to evaluate changes in liabilities arising from financing activities, including both changes arising from cash flows and non-cash changes, suggesting inclusion of a reconciliation between the opening and closing balances in the Restated Statement of Assets and Liabilities for liabilities arising from financing activities, to meet the disclosure requirement. The adoption of amendment did not have any material impact on the Restated Statement of Cash Flows.

2. Figures in brackets represent outflow of cash and cash equivalents

3. The above statement should be read with the Basis of Preparation - Significant Accounting Policies and Statement On First Time Adoption of Ind AS and Adjustments to Audited Financial Statements appearing in Annexure V and Annexure VII of Restated Financial Information, respectively.

As per our report of even date attached

**For Gojanur & Co.**  
**Chartered Accountants**  
**FRN: 000941S**

**For and on behalf of the Board of Directors of**  
**Vishwaraj Sugar Industries Limited**

**G. M. Channappa Shetty**  
**Proprietor**  
**M. No. 020227**

**Nikhil Katti**  
**Managing Director**

**Mukesh Kumar**  
**Director**

**Sheshagiri Kulkarni**  
**Chief Financial Officer**

**Sneha Patil**  
**Company Secretary**

Place: Bellad Bagewadi  
Date: July 08, 2019

Place: Bellad Bagewadi  
Date: July 08, 2019

**RESTATED STATEMENT OF CHANGES IN EQUITY**  
(Amounts in ₹ lakhs, unless otherwise stated)

**Annexure IV**

**a. Equity**

Particulars	As at March 31,									
	2019		2018		2017		2016		2015	
	Number	Amount	Number	Amount	Number	Amount	Number	Amount	Number	Amount
Equity shares of ₹ 10 each issued, subscribed and fully paid	34,556,000	3,455.60	34,556,000	3,455.60	34,556,000	3,455.60	34,556,000	3,455.60	34,556,000	3,455.60
Balance at the beginning of the period	34,556,000	3,455.60	34,556,000	3,455.60	34,556,000	3,455.60	34,556,000	3,455.60	34,556,000	3,455.60
Issue of share capital	-	-	-	-	-	-	-	-	-	-
<b>Balance at the end of the period</b>	<b>34,556,000</b>	<b>3,455.60</b>	<b>34,556,000</b>	<b>3,455.60</b>	<b>34,556,000</b>	<b>3,455.60</b>	<b>34,556,000</b>	<b>3,455.60</b>	<b>34,556,000</b>	<b>3,455.60</b>

**b. Other Equity**

Particulars	Reserves and surplus			Other comprehensive income		Total Equity
	Securities Premium	General Reserve	Retained earnings	Re-measurement losses on defined benefit plans		
<b>Balance as of 1 April 2014</b>	<b>1,466.39</b>	-	<b>18,536.23</b>	-	-	<b>20,002.62</b>
Profit for the year FY 14-15	-	-	(57.68)	-	-	(57.68)
Other comprehensive income for the year	-	-	-	-	(9.49)	(9.49)
Less: Dividend paid during the year	-	-	(401.62)	-	-	(401.62)
<b>Balance as of 1 April 2015</b>	<b>1,466.39</b>	-	<b>18,076.92</b>	-	<b>(9.49)</b>	<b>19,533.83</b>
Profit for the year FY 2015-16	-	-	85.35	-	-	85.35
Other comprehensive income for the year	-	-	-	-	(48.64)	(48.64)
Less: Dividend paid during the year	-	-	(416.87)	-	-	(416.87)
<b>Balance as of 1 April 2016</b>	<b>1,466.39</b>	-	<b>17,745.40</b>	-	<b>(58.13)</b>	<b>19,153.67</b>
Profit for the year FY 2016-17	-	-	606.25	-	-	606.25
Other comprehensive income for the year	-	-	-	-	33.28	33.28
Less: Dividend paid during the year	-	-	-	-	-	-
<b>Balance as at 31 March 2017</b>	<b>1,466.39</b>	-	<b>18,351.65</b>	-	<b>(24.85)</b>	<b>19,793.20</b>
Profit for the year FY 2017-18	-	-	(426.67)	-	-	(426.67)

Other comprehensive income for the year			-	-	65.82	65.82
Less: Dividend paid during the year			-	-		-
<b>Balance as at 31 March 2018</b>	<b>1,466.39</b>	<b>-</b>	<b>17,924.98</b>	<b>-</b>	<b>40.97</b>	<b>19,432.34</b>
Profit for the year FY 2018-19	-	-	(1,761.99)	-	-	(1,761.99)
Other comprehensive income for the year					23.74	23.74
Less: Dividend paid during the year			-	-	-	-
<b>Balance as at 31 March 2019</b>	<b>1,466.39</b>	<b>-</b>	<b>16,162.99</b>	<b>-</b>	<b>64.71</b>	<b>17,694.09</b>

The above statement should be read with the basis of preparation and significant accounting policies and statement on adjustments to audited financial statements appearing in Annexure V and Annexure VII of Restated Financial Information, respectively.

As per our report of even date attached

**For Gojanur & Co.**  
**Chartered Accountants**  
**FRN: 000941S**

**For and on behalf of the Board of Directors of**  
**Vishwaraj Sugar Industries Limited**

**G. M. Channappa Shetty**  
**Proprietor**  
**M. No. 020227**

**Nikhil Katti**  
**Managing Director**

**Mukesh Kumar**  
**Director**

**Sheshagiri Kulkarni**  
**Chief Financial Officer**

**Sneha Patil**  
**Company Secretary**

Place: Bellad Bagewadi  
Date: July 08, 2019

Place: Bellad Bagewadi  
Date: July 08, 2019



## Annexure V: Restated Statement of Significant Accounting Policies

### DESCRIPTION OF THE COMPANY AND SIGNIFICANT ACCOUNTING POLICIES

#### 1) General Information

Vishwaraj Sugar Industries Limited (the company) domiciled and Incorporated in India in accordance with the provisions of the Companies Act, 1956. The Company is engaged in the Production of sugar, alcoholic spirits by distillation including ethanol, blending and bottling of Indian Made Liquor (IML), vinegar and generation of power. The principal accounting policies applied in the preparation of the financial statements are set out below. These policies have been consistently applied to all the years presented, unless otherwise stated.

#### 2) Basis of preparation and presentation of Financial Statements

The Restated financial statements of Assets and Liabilities as at March 31, 2019, 2018, 2017, 2016 and 2015 and Restated Statement of Profit and Loss, Restated Statement of Cash Flows and the Restated Statement of Changes in Equity for the years ended March 31, 2019, 2017, 2016 and 2015 (together referred to as “Restated Financial Information”) have been compiled by the Company from the Ind AS Audited Financial Statements for F. Y. 2018-19 and F. Y. 2017-18 and Indian GAAP Audited Financial Statements for F. Y. 2016-17, F. Y. 2015-16 and F. Y. 2014-15, to which further adjustments are made to comply in all material aspects with the requirements of the Securities and Exchange Board of India (Issue of Disclosure and Capital Requirements) Regulations, 2009, as amended (the “ICDR Regulations”). Accordingly, these Restated Financial Information have been prepared after incorporating adjustments for the material amounts in the respective financial years to which they relate as explained later. There were no exceptional items that needed to be disclosed separately for the respective years under consideration.

The Restated Financial Statements have been prepared and presented in accordance with the Indian Accounting Standards (“**Ind AS**”) notified under Section 133 of the Companies Act, 2013 (“**the Act**”) read with Companies (Indian Accounting Standards) Rules, 2015 and Companies (Indian Accounting Standards) (Amendment) Rules, 2016 and other relevant provisions of the Act.

#### 3) Basis of Measurement

These Restated Financial Statements have been prepared on the historical cost convention and on an accrual basis, except for the following material items in the balance sheet:

- Certain financial assets and liabilities are measured either at fair value or at amortized cost depending on the classification;
- Net defined benefit assets / (liability) are measured at fair value of plan assets, less present value of defined benefit obligations.

#### 4) Use of estimates and judgments

The preparation of Restated Financial Information in conformity with Ind AS requires management to make judgments, estimates and assumptions that affect the application of accounting policies and the reported amounts of assets and liabilities, the disclosures of contingent assets and liabilities at the restated statement of assets and liabilities date and reported amounts of revenues and expenses for the reporting period. Accounting estimates could change from period to period. Actual results could differ from those estimates. Appropriate changes in estimates are made as management becomes aware of changes in circumstances surrounding the estimates. Changes in estimates are reflected in the financial information in the period in which changes are made and in any future periods affected.

Information about significant areas of estimation uncertainty and critical judgments in applying accounting policies that have the most significant effect on the amounts recognized in the Restated Financial Information is included in the following notes:

- Useful lives of property, plant and equipment and intangible assets;
- Impairment of non-financial and financial assets;
- Financial instruments;

- Employee benefits;
- Provisions, contingencies; and
- Income taxes.

## 5) Summary of Significant Accounting Policies

The Restated Financial Information have been prepared using the accounting policies and measurement basis summarized below.

### a) Functional and presentation currency

These financial statements are presented in Indian rupee (INR or ₹), which is also the functional currency of the Company. All financial information presented in Indian rupees has been rounded to the nearest lakhs.

### b) Current and noncurrent classification

All the assets and liabilities have been classified as current or noncurrent as per the Company's normal operating cycle and other criteria set out in the Schedule III to the Companies Act, 2013 and Ind AS 1, Presentation of financial statements.

*Assets:* An asset is classified as current when it satisfies any of the following criteria:

- ❖ It is expected to be realized in, or is intended for sale or consumption in, the Company's normal operating cycle;
- ❖ It is held primarily for the purpose of being traded;
- ❖ It is expected to be realized within twelve months after the reporting date; or
- ❖ It is cash or cash equivalent unless it is restricted from being exchanged or used to settle a liability for at least twelve months after the reporting date.

*Liabilities:* A liability is classified as current when it satisfies any of the following criteria:

- ❖ It is expected to be settled in the Company's normal operating cycle;
- ❖ It is held primarily for the purpose of being traded;
- ❖ It is due to be settled within twelve months after the reporting date; or
- ❖ The Company does not have an unconditional right to defer settlement of the liability for at least twelve months after the reporting date. Terms of a liability that could, at the option of the counterparty, result in its settlement by the issue of equity instruments do not affect its classification.

Current assets/ liabilities include the current portion of noncurrent assets/ liabilities respectively. All other assets/ liabilities are classified as noncurrent. Deferred tax assets and liabilities are always disclosed as non-current.

### c) Foreign Currency Transaction

Transactions in foreign currencies are translated to the functional currency of the Company at exchange rates at the dates of the transactions. Monetary assets and liabilities denominated in foreign currencies at the reporting period are translated into the functional currency at the exchange rate at that date. Nonmonetary items denominated in foreign currencies which are carried at historical cost are reported using the exchange rate at the date of the transaction; and non-monetary items which are carried at fair value or any other similar valuation denominated in a foreign currency are reported using the exchange rates at the date when the fair value was measured.

Exchange differences arising on monetary items on settlement, or restatement as at reporting date, at rates different from those at which they were initially recorded, are recognized in the statement of profit and loss in the year in which they arise.

### d) Fair valuation

Fair value is the price that would be received to sell an asset or paid to transfer a liability in an orderly transaction between market participants at the measurement date, regardless of whether that price is directly observable or estimated using another valuation technique. In estimating the fair value of an asset or a liability, the Company takes into account the characteristics of the asset or liability at the measurement date. The fair

value measurement is based on the presumption that the transaction to sell the financial asset or settle the financial liability takes place either:

- In the principal market, or
- In the absence of a principal market, in the most advantageous market

The principal or the most advantageous market must be accessible by the Company. A fair value measurement of a non-financial asset takes into account a market participant's ability to generate economic benefits by using the asset in its highest and best use. Fair value measurement and / or disclosure purposes in the Restated Ind AS Financial Information is determined on such a basis, except for measurements that have some similarities to fair value but are not fair value, such as net realizable value in Ind AS 2 or value in use in Ind AS 36.

The Company- uses valuation techniques that are appropriate in the circumstances and for which sufficient data are available to measure fair value, maximizing the use of relevant observable inputs and minimizing the use of unobservable inputs.

All assets and liabilities for which fair value is measured or disclosed in the Restated Ind AS Financial Information are categorized within the fair value hierarchy, described as follows, based on the lowest level input that is significant to the fair value measurement as a whole:

- Level 1 — Quoted (unadjusted) market prices in active markets for identical assets or liabilities
- Level 2 — Valuation techniques for which the lowest level input that is significant to the fair value measurement is directly or indirectly observable
- Level 3 — Valuation techniques for which the lowest level input that is significant to the fair value measurement is unobservable

At each reporting date, the Management analyses the movements in the values of assets and liabilities which are required to be re-measured or re-assessed as per the Company's accounting policies.

For the purpose of fair value disclosures, the Company has determined classes of assets and liabilities on the basis of the nature, characteristics and risks of the asset or liability and the level of the fair value hierarchy as explained above.

#### **Government Grants:**

##### ***Recognition & Measurement***

Grants & Subsidies received from the Governments are recognised only when there is reasonable assurance that:

- a. The company will comply with the conditions attached to the grant
- b. There is a reasonable certainty that the grant will be received.

Government grants related to assets are treated as deferred income and are recognized in net profit in the statement of Profit & Loss on a systematic and rational basis over the useful life of the asset.

Government grants related to revenue are recognized on a systematic basis in net profit in the Statement of Profit & Loss over the periods necessary to match them with the related costs which they are intended to compensate.

#### **e) Revenue Recognition**

##### ***Sale of goods***

Effective April 1, 2018, the Company adopted Ind AS 115 "Revenue from Contracts with Customers" using the cumulative catch-up transition method, applied to contracts that were not completed as of April 1, 2018. In accordance with the cumulative catch-up transition method, the comparatives have not been retrospectively adjusted. The company has insignificant impact on adoption of IND AS 115.

Revenue from goods and services is recognized, when the company satisfies a performance obligation by transferring a promised good or service to its customers. The company considers the terms of the contract and its customary business practices to determine the transaction price. Performance obligations are satisfied at the point of time when the customer obtains controls of the asset.

#### ***Other Income***

Other Income is recognized only when it is reasonably certain that the ultimate collection will be made.

#### ***Interest Income***

Interest Income mainly comprises of interest on Margin money deposit with banks relating to bank guarantee. Interest income should be recorded using the effective interest rate (EIR). However, the amount of margin money deposits relating to bank guarantee are purely current in nature, hence effective interest rate has not been applied. Interest is recognized using the time-proportion method, based on rates implicit in the transactions.

#### ***Dividend***

Dividend income is recognized when the Company's right to receive dividend is established.

#### ***Prior Period Error***

Prior period errors are omissions from, and misstatements in, the entity's financial statements for one or more prior periods arising from a failure to use, or misuse of, reliable information that:

- a. was available when financial statements for those periods were approved for issue; and
- b. could reasonably be expected to have been obtained and taken into account in the preparation and presentation of those financial statements. Such errors include the effects of mathematical mistakes, mistakes in applying accounting policies, oversights or misinterpretations of facts, and fraud

Retrospective restatement is correcting the recognition, measurement and disclosure of amounts of elements of financial statements as if a prior period error had never occurred.

The material prior period errors are corrected retrospectively in the first set of financial statements approved for issue after their discovery by:

- a. restating the comparative amounts for the prior period(s) presented in which the error occurred; or
- b. if the error occurred before the earliest prior period presented, restating the opening balances of assets, liabilities and equity for the earliest prior period presented except in the following circumstance:

A prior period error shall be corrected by retrospective restatement except to the extent that it is impracticable to determine either the period-specific effects or the cumulative effect of the error.

When it is impracticable to determine the period-specific effects of an error on comparative information for one or more prior periods presented, the entity shall restate the opening balances of assets, liabilities and equity for the earliest period for which retrospective restatement is practicable (which may be the current period). When it is impracticable to determine the cumulative effect, at the beginning of the current period, of an error on all prior periods, the entity shall restate the comparative information to correct the error prospectively from the earliest date practicable.

### **f) Property Plant & Equipment**

#### ***Recognition and measurement***

Property, Plant and Equipment are stated at cost of acquisition or construction less accumulated depreciation and impairment loss, if any. Cost includes expenditures that are directly attributable to the acquisition of the asset i.e., freight, duties and taxes applicable and other expenses related to acquisition and installation. The

cost of self-constructed assets includes the cost of materials and other costs directly attributable to bringing the asset to a working condition for its intended use. Borrowing costs that are directly attributable to the construction or production of a qualifying asset are capitalised as part of the cost of that asset.

When parts of an item of property, plant and equipment have different useful lives, they are accounted for as separate items (major components) of property, plant and equipment.

Gains and losses upon disposal of an item of property, plant and equipment are determined by comparing the proceeds from disposal with the carrying amount of property, plant and equipment and are recognized net within in the statement of profit and loss.

The cost of replacing part of an item of property, plant and equipment is recognized in the carrying amount of the item if it is probable that the future economic benefits embodied within the part will flow to the Company and its cost can be measured reliably. The costs of repairs and maintenance are recognized in the statement of profit and loss as incurred.

Items of property, plant and equipment acquired through exchange of non-monetary assets are measured at fair value, unless the exchange transaction lacks commercial substance or the fair value of either the asset received or asset given up is not reliably measurable, in which case the asset exchanged is recorded at the carrying amount of the asset given up.

### ***Depreciation***

Depreciation on items of PPE is provided on written down value basis, computed on the basis of useful lives as estimated by the management which coincides with the useful lives mentioned in Schedule II to the Companies Act, 2013. Assets acquired under finance leases are depreciated over the shorter of the lease term and their useful lives unless it is reasonably certain that the Company will obtain ownership by the end of the lease term. Freehold land and land under perpetual lease are not depreciated.

Depreciation on additions / disposals is provided on a pro-rata basis i.e. from / upto the date on which asset is ready for use / disposed-off.

The residual values, useful lives and method of depreciation are reviewed at each financial year end and adjusted prospectively, if appropriate.

The estimated useful lives are as follows:

<b>Type of Asset</b>	<b>Estimated useful life</b>
Buildings	30
Plant & Machinery	25
Plant & Machinery (IML)	25
Plant & Machinery (Vinegar)	25
Electrical Installations	25
Furniture & Fixtures	10
Office Equipment	5
Computers	6
Vehicles	8

Advances paid towards the acquisition of property, plant and equipment outstanding at each reporting date is disclosed as capital advances under other noncurrent assets. The cost of property, plant and equipment not ready to use before such date are disclosed under capital work-in-progress. Assets not ready for use are not depreciated.

### **g) Intangible assets**

Intangible assets are initially measured at cost. Subsequently, such intangible assets are measured at cost less accumulated amortization and any accumulated impairment losses, if any. Subsequent expenditure is capitalized only when it increases the future economic benefits embodied in the specific asset to which it

relates. All other expenditure, including expenditure on internally generated goodwill and brands, is recognized in statement of profit or loss as incurred.

#### **h) Inventories**

Inventories consist of raw materials, stores and spares, work-in-progress and finished goods . Cost includes expenditures incurred in acquiring the inventories, production or conversion costs and other costs incurred in bringing them to their existing location and condition. In the case of finished goods and work-in-progress, cost includes an appropriate share of overheads based on normal operating capacity.

The method of valuing the inventories is as follows:

- Raw-materials, Stores, Packing materials, Spare parts are valued at cost.
- Finished goods are valued at cost / Net realizable value, whichever is less.
- Stock in process is valued at cost or Net realizable value, whichever is less.
- Waste is valued at net realizable value.
- By product is valued at net realizable value.
- Cost of inventories is ascertained on FIFO basis

Net realisable value is the estimated selling price in the ordinary course of business, less the estimated costs of completion and selling expenses. The net realisable value of work-in-progress is determined with reference to the selling prices of related finished products.

#### **i) Financial Instruments**

A financial instrument is any contract that gives rise to a financial asset of one entity and a financial liability or equity instrument of another entity.

##### ***Financial assets***

###### *Initial recognition and measurement*

All financial assets are recognized initially at fair value plus, in the case of financial assets not recorded at fair value through profit or loss, transaction costs that are attributable to the acquisition of the financial asset. Purchases or sales of financial assets that require delivery of assets within a time frame established by regulation or convention in the market place (regular way trades) are recognized on the trade date, i.e., the date that the Company commits to purchase or sell the asset.

###### *Subsequent measurement*

###### *Debt instrument at FVTPL*

Debt instruments included within the FVTPL category are measured at fair value with all changes recognized in the statement of profit and loss. The Company has not designated any debt instrument as at FVTPL.

###### *Unquoted trade Investments*

Unquoted trade Investments are measured at amortised cost using Effective Rate of Return (EIR).

###### *Investment in equity instruments*

All equity investments in scope of Ind AS 109 are measured at fair value. Equity instruments which are held for trading and contingent consideration recognised by an acquirer in a business combination to which Ind AS103 applies are classified as at FVTPL. For all other equity instruments, the Company may make an irrevocable election to present in other comprehensive income subsequent changes in the fair value. The Company makes such election on an instrument by-instrument basis. The classification is made on initial recognition and is irrevocable.

If the Company decides to classify an equity instrument as at FVTOCI, then all fair value changes on the instrument, excluding dividends, are recognised in the OCI. There is no recycling of the amounts from OCI to the statement of profit and loss, even on sale of investment. However, the Company may transfer the cumulative gain or loss within equity.

Equity instruments i.e., investments in equity shares within the FVTPL category are measured at fair value with all changes recognized in the statement of profit and loss.



### ***De-recognition***

A financial asset (or, where applicable, a part of a financial asset or part of a group of similar financial assets) is primarily derecognized (i.e., removed from the Company's balance sheet) when:

- The rights to receive cash flows from the asset have expired, or
- The Company has transferred its rights to receive cash flows from the asset or has assumed an obligation to pay the received cash flows in full without material delay to a third party under a 'pass-through' arrangement; and either (a) the Company has transferred substantially all the risks and rewards of the asset, or (b) the Company has neither transferred nor retained substantially all the risks and rewards of the asset, but has transferred control of the asset.

When the Company has transferred its rights to receive cash flows from an asset or has entered into a pass-through arrangement, it evaluates if and to what extent it has retained the risks and rewards of ownership. When it has neither transferred nor retained substantially all of the risks and rewards of the asset, nor transferred control of the asset, the Company continues to recognize the transferred asset to the extent of the Company's continuing involvement. In that case, the Company also recognizes an associated liability. The transferred asset and the associated liability are measured on a basis that reflects the rights and obligations that the Company has retained.

### ***Impairment of trade receivables***

In accordance with Ind AS 109, the Company applies expected credit loss (ECL) model for measurement and recognition of impairment loss on the trade receivables or any contractual right to receive cash or another financial asset that result from transactions that are within the scope of Ind AS 18. Expected credit loss model takes into consideration the present value of all the cash shortfalls over the expected life of a financial instrument. In simple terms, it is weighted average of credit losses with the respective risks of default occurring as weights. The credit loss is the difference between all contractual cash flows that are due to an entity as per the contract and all the contractual cash flows that the entity expects to receive, discounted to the effective interest rate. The Standard presumes that entities would suffer credit loss even if the entity expects to be paid in full but later than when contractually due. In other words, it simply focuses on DELAYS in collection of receivables.

For the purpose of identifying the days of delay, the Company took into consideration the weighted average number of delays taking into consideration the date of billing, the credit period and the collection days.

### ***Financial liabilities***

#### ***Initial recognition and measurement***

Financial liabilities are classified, at initial recognition, as financial liabilities at fair value through profit or loss, loans and borrowings, payables, or as derivatives designated as hedging instruments in an effective hedge, as appropriate. All financial liabilities are recognized initially at fair value and, in the case of loans and borrowings and payables, net of directly attributable transaction costs.

The Company's financial liabilities include trade and other payables, loans and borrowings including bank overdrafts, financial guarantee contracts.

#### ***Subsequent measurement***

The measurement of financial liabilities depends on their classification, as described below:

#### ***Loans and borrowings***

After initial recognition, interest-bearing loans and borrowings are subsequently measured at amortized cost using the EIR method. Gains and losses are recognized in the statement of profit and loss when the liabilities are derecognized as well as through the EIR amortization process.

Amortized cost is calculated by taking into account any discount or premium on acquisition and fees or costs that are an integral part of the EIR. The EIR amortization is included as finance costs in the statement of profit and loss.

**j) Impairment of non-financial assets**

The carrying amounts of the Company's non-financial assets, other than inventories and deferred tax assets are reviewed at each reporting date to determine whether there is any indication of impairment. If any such indication exists, then the asset's recoverable amount is estimated. For goodwill and intangible assets that have indefinite lives or that are not yet available for use, an impairment test is performed each year at March 31.

The recoverable amount of an asset or cash-generating unit (as defined below) is the greater of its value in use and its fair value less costs to sell. In assessing value in use, the estimated future cash flows are discounted to their present value using a pre-tax discount rate that reflects current market assessments of the time value of money and the risks specific to the asset or the cash-generating unit. For the purpose of impairment testing, assets are grouped together into the smallest group of assets that generates cash inflows from continuing use that are largely independent of the cash inflows of other assets or groups of assets (the "cash-generating unit").

An impairment loss is recognized in the statement of profit and loss if the estimated recoverable amount of an asset or its cash-generating unit is lower than its carrying amount. Impairment losses recognized in respect of cash-generating units are allocated first to reduce the carrying amount of any goodwill allocated to the units and then to reduce the carrying amount of the other assets in the unit on a pro-rata basis.

An impairment loss in respect of goodwill is not reversed. In respect of other assets, impairment losses recognized in prior periods are assessed at each reporting date for any indications that the loss has decreased or no longer exists. An impairment loss is reversed if there has been a change in the estimates used to determine the recoverable amount. An impairment loss is reversed only to the extent that the asset's carrying amount does not exceed the carrying amount that would have been determined, net of depreciation or amortization, if no impairment loss had been recognized.

**k) Cash & Cash Equivalents**

Cash and bank balances comprise of cash balance in hand, in current accounts with banks, demand deposit, short-term deposits and Margin Money deposits. For this purpose, "short-term" means investments having maturity of three months or less from the date of investment. Bank overdrafts that are repayable on demand and form an integral part of our cash management are included as a component of cash and cash equivalents for the purpose of the statement of cash flows. The Margin money deposits shall be disclosed as restricted cash balances.

**l) Employee Benefits*****Short term employee benefits***

Short-term employee benefits are expensed as the related service is provided. A liability is recognized for the amount expected to be paid if the Company has a present legal or constructive obligation to pay this amount as a result of past service provided by the employee and the obligation can be estimated reliably.

***Defined Contribution Plan***

The Company's contributions to defined contribution plans are charged to the statement of profit and loss as and when the services are received from the employees.

***Defined Benefit Plans***

The liability in respect of defined benefit plans and other post-employment benefits is calculated using the projected unit credit method consistent with the advice of qualified actuaries. The present value of the defined benefit obligation is determined by discounting the estimated future cash outflows using interest rates based on prevailing market yields of Indian Government Bonds and that have terms to maturity approximating to the terms of the related defined benefit obligation. The current service cost of the defined benefit plan, recognized in the statement of profit and loss in employee benefit expense, reflects the increase in the defined benefit obligation resulting from employee service in the current year, benefit changes, curtailments and settlements. Past service costs are recognized immediately in income. The net interest cost is calculated by applying the discount rate to the net balance of the defined benefit obligation and the fair value of plan assets. This cost is included in employee benefit expense in the statement of profit and loss. Actuarial gains and losses arising

from experience adjustments and changes in actuarial assumptions are charged or credited to equity in other comprehensive income in the period in which they arise.

#### ***Termination benefits***

Termination benefits are recognized as an expense when the Company is demonstrably committed, without realistic possibility of withdrawal, to a formal detailed plan to either terminate employment before the normal retirement date, or to provide termination benefits as a result of an offer made to encourage voluntary redundancy. Termination benefits for voluntary redundancies are recognized as an expense if the Company has made an offer encouraging voluntary redundancy, it is probable that the offer will be accepted, and the number of acceptances can be estimated reliably.

#### ***Other long-term employee benefits***

The Company's net obligation in respect of other long term employee benefits is the amount of future benefit that employees have earned in return for their service in the current and previous periods. That benefit is discounted to determine its present value. Re-measurements are recognized in the statement of profit and loss in the period in which they arise.

#### **m) Borrowing Costs**

Borrowing costs consist of interest, ancillary and other costs that the Company incurs in connection with the borrowing of funds and interest relating to other financial liabilities. Borrowing costs also include exchange differences to the extent regarded as an adjustment to the borrowing costs. Borrowing costs directly attributable to the acquisition, construction or production of an asset that necessarily takes a substantial period of time to get ready for its intended use or sale are capitalized as part of the cost of the asset. All other borrowing costs are expensed in the period in which they occur.

#### **n) Operating lease:**

Lease payments under an operating lease shall be recognized as an expense on a straight-line basis over the lease term unless another systematic basis is more representative of the time pattern of the user's benefit.

#### **o) Provisions, contingent liabilities and contingent assets**

A provision is recognized if, as a result of a past event, the Company has a present legal or constructive obligation that can be estimated reliably, and it is probable that an outflow of economic benefits will be required to settle the obligation. If the effect of the time value of money is material, provisions are determined by discounting the expected future cash flows at a pre-tax rate that reflects current market assessments of the time value of money and the risks specific to the liability. Where discounting is used, the increase in the provision due to the passage of time is recognized as a finance cost.

#### ***Contingent liabilities***

A disclosure for a contingent liability is made when there is a possible obligation or a present obligation that may, but probably will not, require an outflow of resources. Where there is a possible obligation or a present obligation in respect of which the likelihood of outflow of resources is remote, no provision or disclosure is made.

#### ***Contingent assets***

Contingent assets are not recognized in the financial statements. However, contingent assets are assessed continually and if it is virtually certain that an inflow of economic benefits will arise, the asset and related income are recognized in the period in which the change occurs.

#### **p) Tax Expenses**

Tax expense consists of current and deferred tax.

#### ***Income Tax***

Income tax expense is recognized in the statement of profit and loss except to the extent that it relates to items recognized directly in equity, in which case it is recognized in equity. Current tax is the expected tax payable on the taxable income for the year, using tax rates enacted or substantively enacted at the reporting date, and any adjustment to tax payable in respect of previous years.

#### ***Deferred Tax***

Deferred tax is recognized using the balance sheet method, providing for temporary differences between the carrying amounts of assets and liabilities for financial reporting purposes and the amounts used for taxation purposes. Deferred tax is measured at the tax rates that are expected to be applied to the temporary differences when they reverse, based on the laws that have been enacted or substantively enacted by the reporting date. Deferred tax assets and liabilities are offset if there is a legally enforceable right to offset current tax liabilities and assets, and they relate to income taxes levied by the same tax authority on the same taxable entity, or on different tax entities, but they intend to settle current tax liabilities and assets on a net basis or their tax assets and liabilities will be realized simultaneously.

A deferred tax asset is recognized to the extent that it is probable that future taxable profits will be available against which the temporary difference can be utilized. Deferred tax assets are reviewed at each reporting date and are reduced to the extent that it is no longer probable that the related tax benefit will be realized.

#### **q) Earnings Per Share**

The Company presents basic and diluted earnings per share (“EPS”) data for its ordinary shares. The basic earnings per share is computed by dividing the net profit after tax by the weighted average number of equity shares outstanding during the period. Diluted earnings per share is computed by dividing the profit after tax by the weighted average number of equity shares considered for deriving basic earnings per share and also the weighted average number of equity shares that could have been issued upon conversion of all dilutive potential equity shares.

**Annexure VI: Statement of Notes to the Restated Financial Information**  
(Amounts in ₹ lakhs, unless otherwise stated)

**2. Property, Plant & Equipment**

As at March 31, 2019

Particulars		Land		Buildings		Plant & Machinery	Vehicles	Office Equipments	Furniture & Fixtures	Total
		Freehold	Leasehold	Factory	Others					
Gross Block as on 1-04-2018	Opening	461.54	-	4,105.02	3,304.68	23,269.58	523.84	47.15	76.08	<b>31,787.89</b>
	Additions	127.34	-	69.51	10.68	504.34	53.91	1.35	23.43	<b>790.57</b>
	Deletions	-	-	-	-	345.53	13.65	-	-	<b>359.18</b>
<b>A</b>	<b>Total</b>	<b>588.88</b>	<b>-</b>	<b>4,174.53</b>	<b>3,315.36</b>	<b>23,428.39</b>	<b>564.10</b>	<b>48.50</b>	<b>99.51</b>	<b>32,219.28</b>
Depreciation	Opening	-	-	590.96	168.47	3,538.14	243.89	17.02	40.61	<b>4,599.09</b>
	Additions	-	-	159.26	53.39	1,053.40	51.44	7.05	9.73	<b>1,334.28</b>
	Deletions	-	-	-	0.06	147.92	6.65	-	-	<b>154.63</b>
<b>B</b>	<b>Total</b>	<b>-</b>	<b>-</b>	<b>750.22</b>	<b>221.80</b>	<b>4,443.61</b>	<b>288.68</b>	<b>24.08</b>	<b>50.34</b>	<b>5,778.74</b>
<b>Capital Work In Progress</b>										<b>1,126.02</b>
<b>WDV as on 31-3-2019</b>	<b>(A - B)</b>	<b>588.88</b>	<b>-</b>	<b>3,424.31</b>	<b>3,093.56</b>	<b>18,984.78</b>	<b>275.42</b>	<b>24.42</b>	<b>49.17</b>	<b>26,440.54</b>

As at March 31, 2018

Particulars		Land		Buildings		Plant & Machinery	Vehicles	Office Equipments	Furniture & Fixtures	Total
		Freehold	Leasehold	Factory	Others					
Gross Block as on 01-04-2017	Opening	461.54	-	4,017.79	3,045.82	19,184.22	531.78	31.57	76.08	<b>27,348.79</b>
	Additions	-	-	87.24	258.86	4,085.37	-	15.58	-	<b>4,490.22</b>
	Deletions	-	-	-	-	-	7.94	-	-	<b>51.12</b>
<b>A</b>	<b>Total</b>	<b>461.54</b>	<b>-</b>	<b>4,105.02</b>	<b>3,304.68</b>	<b>23,269.58</b>	<b>523.84</b>	<b>47.15</b>	<b>76.08</b>	<b>31,787.89</b>
Depreciation	Opening	-	-	433.89	115.24	2,503.90	183.03	10.18	33.10	<b>3,279.36</b>
	Additions	-	-	157.06	53.23	1,034.23	61.09	6.84	7.51	<b>1,319.96</b>
	Deletions	-	-	-	-	-	0.23	-	-	<b>0.23</b>
<b>B</b>	<b>Total</b>	<b>-</b>	<b>-</b>	<b>590.96</b>	<b>168.47</b>	<b>3,538.14</b>	<b>243.89</b>	<b>17.02</b>	<b>40.61</b>	<b>4,599.09</b>
<b>Capital Work In Progress</b>										
<b>WDV as on 31-03-2018</b>	<b>(A - B)</b>	<b>461.54</b>	<b>-</b>	<b>3,514.07</b>	<b>3,136.21</b>	<b>19,731.44</b>	<b>279.95</b>	<b>30.13</b>	<b>35.47</b>	<b>27,188.80</b>

**Annexure VI: Statement of Notes to the Restated Financial Information**  
(Amounts in ₹ lakhs, unless otherwise stated)

**Property, Plant & Equipment (contd.)**

As at March 31, 2017

		Land		Buildings		Plant & Machinery	Vehicles	Office Equipments	Furniture & Fixtures	Total
		Freehold	Leasehold	Factory	Others					
Gross Block as on 01-04-2016	Opening	446.66	-	3,696.70	2,739.84	19,088.35	478.95	28.73	76.08	<b>26,555.31</b>
	Additions	14.88	-	321.09	305.98	95.86	95.69	2.85	-	<b>836.35</b>
	Deletions	-	-	-	-	-	42.86	-	-	<b>42.86</b>
<b>A</b>	<b>Total</b>	<b>461.54</b>	<b>-</b>	<b>4,017.79</b>	<b>3,045.82</b>	<b>19,184.22</b>	<b>531.78</b>	<b>31.57</b>	<b>76.08</b>	<b>27,348.79</b>
Depreciation	Opening	-	-	279.32	66.12	1,627.74	137.03	6.28	25.59	<b>2,142.08</b>
	Additions	-	-	154.57	49.13	876.17	62.20	3.90	7.51	<b>1,153.47</b>
	Deletions	-	-	-	-	-	16.20	-	-	<b>16.20</b>
<b>B</b>	<b>Total</b>	<b>-</b>	<b>-</b>	<b>433.89</b>	<b>115.24</b>	<b>2,503.90</b>	<b>183.03</b>	<b>10.18</b>	<b>33.10</b>	<b>3,279.36</b>
<b>Capital Work In Progress</b>										<b>3,834.55</b>
<b>WDV as on 31-03-2017</b>	<b>(A - B)</b>	<b>461.54</b>	<b>-</b>	<b>3,583.89</b>	<b>2,930.58</b>	<b>16,680.31</b>	<b>348.75</b>	<b>21.39</b>	<b>42.97</b>	<b>24,069.44</b>

As at March 31, 2016

		Land		Buildings		Plant & Machinery	Vehicles	Office Equipments	Furniture & Fixtures	Total
		Freehold	Leasehold	Factory	Others					
Gross Block as on 01-04-2015	Opening	446.66	-	3,597.59	2,124.32	18,894.15	458.65	9.65	76.08	<b>25,607.11</b>
	Additions	-	-	99.11	615.52	206.99	20.30	19.08	-	<b>960.99</b>
	Deletions	-	-	-	-	12.79	-	-	-	<b>12.79</b>
<b>A</b>	<b>Total</b>	<b>446.66</b>	<b>-</b>	<b>3,696.70</b>	<b>2,739.84</b>	<b>19,088.35</b>	<b>478.95</b>	<b>28.73</b>	<b>76.08</b>	<b>26,555.31</b>
Depreciation	Opening	-	-	136.49	26.71	757.24	70.50	4.59	12.80	<b>1,008.32</b>
	Additions	-	-	142.83	39.41	870.70	66.53	1.69	12.80	<b>1,133.96</b>
	Deletions	-	-	-	-	0.20	-	-	-	<b>0.20</b>
<b>B</b>	<b>Total</b>	<b>-</b>	<b>-</b>	<b>279.32</b>	<b>66.12</b>	<b>1,627.74</b>	<b>137.03</b>	<b>6.28</b>	<b>25.59</b>	<b>2,142.08</b>
<b>Capital Work In Progress</b>										<b>128.82</b>
<b>WDV as on 31-03-2016</b>	<b>(A - B)</b>	<b>446.66</b>	<b>-</b>	<b>3,417.38</b>	<b>2,673.72</b>	<b>17,460.62</b>	<b>341.92</b>	<b>22.44</b>	<b>50.48</b>	<b>24,413.23</b>



**Annexure VI: Statement of Notes to the Restated Financial Information**  
(Amounts in ₹ lakhs, unless otherwise stated)

**Property, Plant & Equipment (contd.)**

As at March 31, 2015

		Land		Buildings		Plant & Machinery	Vehicles	Office Equipments	Furniture & Fixtures	Total
		Freehold	Leasehold	Factory	Others					
Deemed cost as on 1.4.2014 (Net block as 31.03.2014)	Opening	446.66	-	3,347.05	1,135.18	13,127.29	424.27	7.39	76.08	<b>18,563.92</b>
	Additions	-	-	250.54	989.14	5,766.86	44.38	2.27	-	<b>7,053.19</b>
	Deletions	-	-	-	-	-	10.00	-	-	<b>10.00</b>
<b>A</b>	<b>Total</b>	<b>446.66</b>	<b>-</b>	<b>3,597.59</b>	<b>2,124.32</b>	<b>18,894.15</b>	<b>458.65</b>	<b>9.65</b>	<b>76.08</b>	<b>25,607.11</b>
Depreciation	Opening	-	-	-	-	-	-	-	-	-
	Additions	-	-	136.49	26.71	757.24	73.51	4.59	12.80	<b>1,011.33</b>
	Deletions	-	-	-	-	-	3.01	-	-	<b>3.01</b>
<b>B</b>	<b>Total</b>	<b>-</b>	<b>-</b>	<b>136.49</b>	<b>26.71</b>	<b>757.24</b>	<b>70.50</b>	<b>4.59</b>	<b>12.80</b>	<b>1,008.32</b>
<b>Capital Work In Progress</b>										<b>508.21</b>
<b>WDV as on 31-03-2015</b>	<b>(A - B)</b>	<b>446.66</b>	<b>-</b>	<b>3,461.11</b>	<b>2,097.62</b>	<b>18,136.92</b>	<b>388.15</b>	<b>5.06</b>	<b>63.28</b>	<b>24,598.79</b>

**Annexure VI: Statement of Notes to the Restated Financial Information**  
(Amounts in ₹ lakhs, unless otherwise stated)

**3. Non-Current Investments**

Particulars	As at March 31,				
	2019	2018	2017 (Proforma)	2016 (Proforma)	2015 (Proforma)
<b>Non Trade Investments</b>					
<b>Unquoted investments in equity instruments at FVTPL</b>					
Bellad Bagewadi Urban Souhard Sahakari Shares	0.10	0.10	0.10	0.10	0.10
BDCC Bank Shares	108.14	53.14	37.88	37.55	37.55
Equity Shares Fully Paid-up	108.24	53.24	37.98	37.65	37.65
Aggregate amount of quoted investment and market value thereof	-	-	-	-	-
Aggregate amount of unquoted investments	108.24	53.24	37.98	37.65	37.65
Aggregate amount of impairment in value of investments	-	-	-	-	-
<b>Total Non-Current Investments</b>	<b>108.24</b>	<b>53.24</b>	<b>37.98</b>	<b>37.65</b>	<b>37.65</b>

**4. Other Non-Current Financial Assets**

Particulars	As at March 31,				
	2019	2018	2017 (Proforma)	2016 (Proforma)	2015 (Proforma)
Security Deposits	214.60	213.45	262.89	263.18	265.18
<b>Total</b>	<b>214.60</b>	<b>213.45</b>	<b>262.89</b>	<b>263.18</b>	<b>265.18</b>

**5. Inventories**

Particulars	As at March 31,				
	2019	2018	2017 (Proforma)	2016 (Proforma)	2015 (Proforma)
<b>Valued at lower of cost and net realisable value.</b>					
- Raw Materials	2,405.52	1,178.60	657.27	1,790.06	2,455.57
- Stores & Spares	555.16	558.00	495.11	449.05	421.37
- Process Stocks	-	-	-	-	214.13
- Finished Goods	29,473.94	24,420.60	17,047.46	22,207.46	23,862.92
<b>Total</b>	<b>32,434.62</b>	<b>26,157.20</b>	<b>18,199.84</b>	<b>24,446.57</b>	<b>26,953.98</b>

**Annexure VI: Statement of Notes to the Restated Financial Information**  
(Amounts in ₹ lakhs, unless otherwise stated)

**6. Trade Receivables**

Particulars	As at March 31,				
	2019	2018	2017 (Proforma)	2016 (Proforma)	2015 (Proforma)
<b>Secured</b>					
O/s More than six months					
- Promoters / Promoter Group	-	-	-	-	-
- Others: Considered Good	-	-	-	-	-
O/s Less than six months					
- Promoters / Promoter Group	-	-	-	-	-
- Others: Considered Good	-	-	-	-	-
<b>Unsecured</b>					
O/s More than six months					
- Promoters / Promoter Group	83.68	-	-	-	-
- Others: Considered Good	2,413.51	2,254.00	3,321.42	351.08	524.55
O/s Less than six months					
- Promoters / Promoter Group	-	-	-	-	-
- Others: Considered Good	2,001.78	1,534.41	1,270.59	1,616.02	791.97
<b>Sub - Total</b>	<b>4,498.97</b>	<b>3,788.41</b>	<b>4,592.01</b>	<b>1,967.10</b>	<b>1,316.52</b>
Less: Expected Credit Loss	663.11	400.35	156.62	109.92	66.73
<b>Total</b>	<b>3,835.87</b>	<b>3,388.06</b>	<b>4,435.39</b>	<b>1,857.18</b>	<b>1,249.79</b>

**7. Cash and Cash Equivalents**

Particulars	As at March 31,				
	2019	2018	2017 (Proforma)	2016 (Proforma)	2015 (Proforma)
<b>Cash in hand and as Imprest</b>	-	-	-	-	-
- Cash in Hand	18.39	13.12	12.04	13.67	14.15
<b>Cash at Banks</b>					
- In Current Account	150.97	657.90	1,230.03	5,122.14	1,963.40
<b>Total</b>	<b>169.35</b>	<b>671.02</b>	<b>1,242.07</b>	<b>5,135.81</b>	<b>1,977.55</b>

**8. Bank Balance Other Than Above**

Particulars	As at March 31,				
	2019	2018	2017 (Proforma)	2016 (Proforma)	2015 (Proforma)
<b>Bank Balances</b>					
- As Margin Money	15.00	74.70	31.58	29.13	14.88
<b>Total</b>	<b>15.00</b>	<b>74.70</b>	<b>31.58</b>	<b>29.13</b>	<b>14.88</b>

**9. Other Current Financial Assets**

Particulars	As at March 31,				
	2019	2018	2017 (Proforma)	2016 (Proforma)	2015 (Proforma)
Other Financial Assets	4.47	4.61	15.52	44.64	0.22
<b>Total</b>	<b>4.47</b>	<b>4.61</b>	<b>15.52</b>	<b>44.64</b>	<b>0.22</b>

**Annexure VI: Statement of Notes to the Restated Financial Information**  
(Amounts in ₹ lakhs, unless otherwise stated)

**10. Other Current Assets**

Particulars	As at March 31,				
	2019	2018	2017 (Proforma)	2016 (Proforma)	2015 (Proforma)
Secured, considered good, unless otherwise stated					
Balances with Statutory Authorities	347.58	821.86	385.58	500.20	780.25
Other Current Assets (including Advances to Suppliers & Services)	7,258.68	3,845.70	1,805.15	2,042.12	4,114.71
Less : Allowances for doubtful assets	-	-	-	-	-
<b>Total</b>	<b>7,606.26</b>	<b>4,667.56</b>	<b>2,190.73</b>	<b>2,542.33</b>	<b>4,894.96</b>

**11. Equity Share Capital**

Particulars	As at March 31,				
	2019	2018	2017 (Proforma)	2016 (Proforma)	2015 (Proforma)
<b>Authorised:</b>					
6,00,00,000 Equity Shares of ₹ 10 each	6,000.00	6,000.00	6,000.00	6,000.00	6,000.00
<b>Issued &amp; Subscribed:</b>					
3,45,56,000 Equity Shares of ₹ 10 each	3,455.60	3,455.60	3,455.60	3,455.60	3,455.60
<b>Paid up:</b>					
3,45,56,000 Equity Shares of ₹ 10 each	3,455.60	3,455.60	3,455.60	3,455.60	3,455.60

a. Details of Shareholder(s) holding more than 5% shares are as follows:

Particulars	As at March 31,				
	2019	2018	2017 (Proforma)	2016 (Proforma)	2015 (Proforma)
Nikhil Umesh Katti	369.29	369.29	365.61	365.61	365.61
% of Total Shareholding	10.69%	10.69%	10.58%	10.58%	10.58%

**Annexure VI: Statement of Notes to the Restated Financial Information**  
(Amounts in ₹ lakhs, unless otherwise stated)

**12. Other Equity**

Particulars	As at March 31,				
	2019	2018	2017 (Proforma)	2016 (Proforma)	2015 (Proforma)
<b>Security Premium</b>					
Securities Premium Reserve	1,466.39	1,466.39	1,466.39	1,466.39	1,466.39
<b>Actuarial Gain/ (loss) in OCI</b>	64.71	40.97	(24.85)	(58.13)	(9.49)
<b>Profit &amp; Loss Account</b>					
(i) Opening Balance	17,924.98	18,351.65	17,745.40	18,076.92	19,315.37 <sup>(1)</sup>
Add / (Less): Changes during the year					
<b>Less: Transitional Adjustments</b>					
- Deferred Tax on account of IND AS	-	-	-	-	(752.45)
- Measurement of Employee benefit at Fair Value	-	-	-	-	(1.43)
- Expected Credit Loss	-	-	-	-	(25.26)
(ii) Add: Profit for the year	(1,761.99)	(426.67)	606.25	85.35	(57.68)
Less: Proposed Dividend (@ 10% on paid up capital)	-	-	-	(345.56)	(345.56)
Less: Dividend Distribution Tax	-	-	-	(71.31)	(56.06)
Net Profit Transfer to Reserves	(1,761.99)	(426.67)	606.25	(331.52)	(459.30)
Closing balance	<b>16,162.99</b>	<b>17,924.98</b>	<b>18,351.65</b>	<b>17,745.40</b>	<b>18,076.92</b>
<b>Total</b>	<b>17,694.09</b>	<b>19,432.35</b>	<b>19,793.19</b>	<b>19,153.66</b>	<b>19,533.82</b>

<sup>(1)</sup> Does not include Ind AS effect for first time adoption and the same have been shown separately in the above table

**13. Non Current Borrowings**

Particulars	As at March 31,				
	2019	2018	2017 (Proforma)	2016 (Proforma)	2015 (Proforma)
<b>Secured</b>					
<b>Loans From Banks</b>					
- Term Loans (including Hypothecation Loans)	6,533.31	3,669.41	963.26	2,059.93	3,361.89
- Vehicles Loans	8.12	31.38	36.20	16.85	40.16
<b>Total</b>	<b>6,547.90</b>	<b>3,700.79</b>	<b>999.46</b>	<b>2,076.77</b>	<b>3,402.04</b>

For further details with respect to borrowings, kindly see "Schedule – I - Financial Indebtedness" forming part of this Restated Financial Statements.

**14. Non – Current Provisions**

Particulars	As at March 31,				
	2019	2018	2017 (Proforma)	2016 (Proforma)	2015 (Proforma)
Gratuity	182.65	167.96	209.72	211.65	116.58
<b>Total</b>	<b>182.65</b>	<b>167.96</b>	<b>209.72</b>	<b>211.65</b>	<b>116.58</b>

**Annexure VI: Statement of Notes to the Restated Financial Information**  
(Amounts in ₹ lakhs, unless otherwise stated)

**15. Deferred Tax Liabilities**

Particulars	As at March 31,				
	2019	2018	2017 (Proforma)	2016 (Proforma)	2015 (Proforma)
Opening	1,391.94	1,057.56	841.63	354.70	316.12
Add: Deferred Tax Liabilities during year	(626.72)	334.38	215.93	486.93	38.58
<b>Deferred Tax Liabilities (Net)</b>	<b>765.21</b>	<b>1,391.94</b>	<b>1,057.56</b>	<b>841.63</b>	<b>354.70</b>

**16. Current Borrowings**

Particulars	As at March 31,				
	2019	2018	2017 (Proforma)	2016 (Proforma)	2015 (Proforma)
<b>Secured</b>					
<b>Working Capital Loans</b>					
<i>Bank of India</i>					
Cash Credit - Pledge	9,192.91	7,747.55	3,680.67	5,817.61	5,298.15
Cash Credit - Hypothecation	1,483.33	(0.00)	1,197.50	-	500.00
Harvesting & Transport Loan	5,000.00	5,000.00	5,000.00	5,000.00	5,000.00
<i>SBI</i>					
Cash Credit (SBI) WHR Loan	6,001.44	7,579.12	3,025.82	1,000.56	3,531.21
Cash Credit (SBI) Demand Loan A/c	-	1,641.10	4,262.18	6,328.99	2,104.43
Harvesting & Transport Loan	3,708.00	4,500.00	4,500.00	4,500.00	3,000.00
<b>Total</b>	<b>25,385.68</b>	<b>26,467.77</b>	<b>21,666.16</b>	<b>22,647.16</b>	<b>19,433.79</b>

For further details with respect to borrowings, kindly see "Schedule – I - Financial Indebtedness" forming part of this Restated Financial Statements.

**The above amounts in Note 13 and Note 16 include:**

Particulars	As at March 31,				
	2019	2018	2017 (Proforma)	2016 (Proforma)	2015 (Proforma)
Secured Borrowings <sup>(1)</sup>	33,879.42	31,464.03	23,825.56	26,776.66	23,925.79
Unsecured Borrowings	-	-	-	-	-
<b>Total</b>	<b>33,879.42</b>	<b>31,464.03</b>	<b>23,825.56</b>	<b>26,776.66</b>	<b>23,925.79</b>

<sup>(1)</sup> Including current maturities of Long – Term Debts

**17. Trade Payables**

Particulars	As at March 31,				
	2019	2018	2017 (Proforma)	2016 (Proforma)	2015 (Proforma)
Micro, Small and Medium Enterprises	-	-	-	-	-
Others	11,271.89	2,686.39	1,434.36	2,694.25	5,561.88
<b>Total</b>	<b>11,271.89</b>	<b>2,686.39</b>	<b>1,434.36</b>	<b>2,694.25</b>	<b>5,561.88</b>

**Note 17.1:**

(a) Trade payables include ₹ NIL due to Micro, Small and Medium Enterprises registered under the Micro, Small and Medium Enterprises Development Act, 2006 (MSMED).

(b) The Company is in the process of compiling relevant information from its suppliers about their coverage under the Micro, Small and Medium Enterprises Development Act, 2006. As the Company has not received any intimation from its suppliers as on date regarding their status under the above said Act and hence disclosures if any relating to amounts unpaid as at year end together with the interest paid /payable as required under the said Act have not been given.



**Annexure VI: Statement of Notes to the Restated Financial Information**  
(Amounts in ₹ lakhs, unless otherwise stated)

**18. Other Current Financial Liabilities**

Particulars	As at March 31,				
	2019	2018	2017 (Proforma)	2016 (Proforma)	2015 (Proforma)
Dividends on Equity Shares	-	-	-	102.52	-
Current Maturities of Long-term Debt	1,952.31	1,295.47	1,159.93	2,052.73	1,089.96
Trade Deposits & Advances	1,257.02	491.82	210.47	1,553.53	2,203.88
Other Financial liabilities	507.00	630.17	676.44	644.48	620.17
<b>Total</b>	<b>3,716.34</b>	<b>2,417.46</b>	<b>2,046.84</b>	<b>4,353.25</b>	<b>3,914.01</b>

**19. Other Current Liabilities**

Particulars	As at March 31,				
	2019	2018	2017 (Proforma)	2016 (Proforma)	2015 (Proforma)
Statutory Dues Payable	2,832.35	2,607.02	2,551.95	2,397.45	2,206.02
Other Payables	99.22	57.42	860.78	911.84	2,511.87
<b>Total</b>	<b>2,931.57</b>	<b>2,664.44</b>	<b>3,412.73</b>	<b>3,309.29</b>	<b>4,717.90</b>

**20. Current Provisions**

Particulars	As at March 31,				
	2019	2018	2017 (Proforma)	2016 (Proforma)	2015 (Proforma)
Gratuity Provision	10.49	12.36	12.17	12.27	6.76
<b>Total</b>	<b>10.49</b>	<b>12.36</b>	<b>12.17</b>	<b>12.27</b>	<b>6.76</b>

**21. Current Tax Liabilities (Net)**

Particulars	As at March 31,				
	2019	2018	2017 (Proforma)	2016 (Proforma)	2015 (Proforma)
Income Tax	-	21.58	232.18	143.00	4.13
<b>Total</b>	<b>-</b>	<b>21.58</b>	<b>232.18</b>	<b>143.00</b>	<b>4.13</b>
<b>Tax reconciliation (for profit and loss)</b>					
<b>Profit before income tax expense</b>					
Tax at the rate of (MAT 18.5% + Surcharges + Education Cess) of respective years	-	6.08	223.16	155.45	6.36
Tax adjustments pertaining to earlier year	-	-	-	-	-
Tax expense for the year	-	6.08	223.16	155.45	6.36

**22. Revenue from Operations**

Particulars	For the year ended March 31,				
	2019	2018	2017 (Proforma)	2016 (Proforma)	2015 (Proforma)
Sales (Inclusive of Excise duty)	28,854.46	25,928.30	32,184.21	40,575.83	34,508.36
Other Operating Revenue	1,825.12	-	-	-	-
<b>Total</b>	<b>30,679.58</b>	<b>25,928.30</b>	<b>32,184.21</b>	<b>40,575.83</b>	<b>34,508.36</b>

**Annexure VI: Statement of Notes to the Restated Financial Information**  
(Amounts in ₹ lakhs, unless otherwise stated)

**23. Other Income**

Particulars	For the year ended March 31,				
	2019	2018	2017 (Proforma)	2016 (Proforma)	2015 (Proforma)
<b>Recurring Other Income</b>					
Dividend Income	3.41	3.40	4.30	0.02	0.03
Rental Income	34.56	13.10	10.52	29.64	14.29
Insurance Claims and Income	51.55	55.46	65.83	19.01	28.06
Other Non - Operating Income	18.44	64.11	23.26	240.07	385.63
<b>Non – Recurring Other Income</b>					
Balances Written – off	-	828.72	-	-	-
<b>Total</b>	<b>107.97</b>	<b>964.80</b>	<b>103.91</b>	<b>288.73</b>	<b>428.02</b>
% of PBT	Negative	Negative	10.10%	39.68%	Negative

**24. Cost of Materials Consumed**

Particulars	For the year ended March 31,				
	2019	2018	2017 (Proforma)	2016 (Proforma)	2015 (Proforma)
Raw Materials Consumed	26,686.96	21,740.92	12,168.01	21,569.89	21,911.71
Stores, Spares, Chemicals & Packing Materials Consumed	978.41	954.86	651.40	1,358.87	1,327.90
<b>Total</b>	<b>27,665.37</b>	<b>22,695.78</b>	<b>12,819.41</b>	<b>22,928.76</b>	<b>23,239.60</b>

**25. Changes in Inventory**

Particulars	For the year ended March 31,				
	2019	2018	2017 (Proforma)	2016 (Proforma)	2015 (Proforma)
<b>Raw Material</b>					
Opening	1,178.60	657.27	1,790.07	2,455.57	2,270.14
Closing	2,405.52	1,178.60	657.27	1,790.07	2,455.57
	<b>(1,226.93)</b>	<b>(521.33)</b>	<b>1,132.80</b>	<b>665.50</b>	<b>(185.43)</b>
<b>Work in Process</b>					
Opening	-	-	-	214.13	137.73
Closing	-	-	-	-	214.13
	-	-	-	214.13	(76.39)
<b>Finished Goods</b>					
Opening	24,420.60	17,047.46	22,207.45	23,862.91	21,801.50
Closing	29,473.94	24,420.60	17,047.46	22,207.45	23,862.91
	<b>(5,053.34)</b>	<b>(7,373.14)</b>	<b>5,159.99</b>	<b>1,655.46</b>	<b>(2,061.41)</b>
<b>Total</b>	<b>(6,280.27)</b>	<b>(7,894.47)</b>	<b>6,292.78</b>	<b>2,535.09</b>	<b>(2,323.23)</b>

**Annexure VI: Statement of Notes to the Restated Financial Information**  
(Amounts in ₹ lakhs, unless otherwise stated)

**26. Other Manufacturing Expenses**

Particulars	For the year ended March 31,				
	2019	2018	2017 (Proforma)	2016 (Proforma)	2015 (Proforma)
Processing, Transportation and Other Charges	526.44	732.38	598.16	753.61	589.39
Power & Fuel	428.74	1,072.00	792.81	722.64	991.20
Repairs - Plant & Machinery	1,103.79	620.96	984.54	978.91	718.07
<b>Total</b>	<b>2,058.96</b>	<b>2,425.34</b>	<b>2,375.51</b>	<b>2,455.17</b>	<b>2,298.66</b>

**27. Employee Benefit Expenses**

Particulars	For the year ended March 31,				
	2019	2018	2017 (Proforma)	2016 (Proforma)	2015 (Proforma)
Salaries and Wages to employees	1,177.38	1,120.88	1,240.96	1,086.05	1,081.88
Contribution to Provident and other Funds	93.93	111.10	117.41	116.22	94.35
Staff Welfare Expenses	31.97	10.99	3.39	13.49	14.42
<b>Total</b>	<b>1,303.28</b>	<b>1,242.97</b>	<b>1,361.77</b>	<b>1,215.76</b>	<b>1,190.65</b>

**28. Finance Cost**

Particulars	For the year ended March 31,				
	2019	2018	2017 (Proforma)	2016 (Proforma)	2015 (Proforma)
Interest Expenses	3,501.06	1,947.10	2,406.97	1,657.46	1,526.11
Other Borrowing Costs	134.63	137.95	84.44	129.88	82.88
<b>Total</b>	<b>3,635.69</b>	<b>2,085.05</b>	<b>2,491.41</b>	<b>1,787.34</b>	<b>1,608.98</b>

**29. Other Expenses**

Particulars	For the year ended March 31,				
	2019	2018	2017 (Proforma)	2016 (Proforma)	2015 (Proforma)
Rent	6.86	6.94	6.89	6.32	5.31
Advt, Publicity & Sales Promotion	352.42	220.28	111.83	1.63	2.17
Insurance	142.06	102.70	96.31	78.21	80.74
Travelling Expenditure	37.63	26.39	33.98	38.29	31.10
Vehicle Running & Maintenance	184.51	146.25	155.21	159.62	145.56
Printing & Stationery	11.70	10.78	9.95	8.89	12.10
Communication Expenses	9.48	16.26	12.64	15.27	16.01
Legal, Professional & Consultancy Charge	74.48	205.85	65.88	64.94	19.80
Discount, Rebate & Commission	18.94	6.83	20.17	43.14	61.51
Loss/(Gain) on Sale / Disposal of Fixed Assets	83.72	5.03	4.79	8.33	5.16
Freight Charges	10.10	11.09	10.03	9.17	18.94
Donation	2.00	2.00	2.50	0.05	43.87
License Fees & Taxes	139.12	220.89	230.21	373.92	449.79
Corporate Social Responsibility Expenses	8.80	14.19	21.80	-	-
Other Miscellaneous Exp	70.08	118.51	137.06	218.58	106.11
Expected Credit Loss	262.76	243.73	46.70	43.19	41.47
<b>Total</b>	<b>1,414.66</b>	<b>1,357.72</b>	<b>965.95</b>	<b>1,069.57</b>	<b>1,039.63</b>

**Annexure VI: Statement of Notes to the Restated Financial Information**  
(Amounts in ₹ lakhs, unless otherwise stated)

**29.1 Payment to Auditors**

Particulars	For the year ended March 31,				
	2019	2018	2017 (Proforma)	2016 (Proforma)	2015 (Proforma)
Audit fees	5.00	5.00	5.00	5.00	4.00
For Other Matters	2.00	2.00	2.00	2.00	1.00
<b>Total</b>	<b>7.00</b>	<b>7.00</b>	<b>7.00</b>	<b>7.00</b>	<b>5.00</b>

**30. Deferred Tax Assets & Liabilities**

The tax effects of significant temporary differences that resulted in deferred tax assets and liabilities and a description of the items that created these differences is given below:

Particulars	For the year ended March 31,				
	2019	2018	2017 (Proforma)	2016 (Proforma)	2015 (Proforma)
Property, plant and equipment	357.16	415.38	96.03	630.49	457.82
MAT Credit Entitlement	-	(21.58)	(232.18)	(142.99)	(4.13)
Accumulated Losses	(971.71)	(76.56)	290.64	6.32	(296.96)
43 B Disallowances	(12.18)	17.14	61.44	(6.89)	(118.17)
<b>Net deferred tax( assets)/liabilities</b>	<b>(626.72)</b>	<b>334.38</b>	<b>215.93</b>	<b>486.93</b>	<b>38.57</b>

**31. Earnings Per Share**

Particulars	For the year ended March 31,				
	2019	2018	2017 (Proforma)	2016 (Proforma)	2015 (Proforma)
Net Profit attributable to equity holders	(1761.99)	(426.67)	606.25	85.35	(57.68)
Calculation of weighted average number of equity shares					
No. of shares at the beginning of the year	345.56	345.56	345.56	345.56	345.56
Add: Allotment during the year	-	-	-	-	-
Add: Effect of Bonus Equity shares issued	-	-	-	-	-
Weighted average number of equity shares outstanding during the year	345.56	345.56	345.56	345.56	345.56
<b>Basic and Diluted EPS</b>	<b>(5.10)</b>	<b>(1.23)</b>	<b>1.75</b>	<b>0.25</b>	<b>(0.17)</b>
Nominal Value per Equity Share	10	10	10	10	10

**Note:** Weighted average number of shares is the number of equity shares outstanding at the beginning of the period/year adjusted by the number of equity shares issued during period/year, multiplied by the time weighting factor. The time weighting factor is the number of days for which the specific shares are outstanding as a proportion of total number of days during the period/year.

**32. Contingent Liability**

Particulars	As at March 31,				
	2019	2018	2017 (Proforma)	2016 (Proforma)	2015 (Proforma)
(a) Court Cases	1,506.15	1,253.66	1,182.31	2,061.99	1,847.84
(b) Bank Guarantee	57.00	143.78	110.28	115.50	58.50
(c) EPCG Export Obligation	289.99	289.99	289.99	-	-
	<b>1,853.14</b>	<b>1,649.43</b>	<b>1,582.58</b>	<b>2,177.49</b>	<b>1,906.34</b>

**Note:** In respect of above matters, future cash outflows in respect of contingent liabilities are determinable only by the occurrence or non-occurrence of one or more uncertain future events not wholly within the control of the Company.

**Annexure VI: Statement of Notes to the Restated Financial Information**  
(Amounts in ₹ lakhs, unless otherwise stated)

**33. As per Indian Accounting Standard-19, 'Employee Benefits', the disclosure of Defined Benefit Plan as defined in the Standard are given below:**

The Company provides for gratuity for employees in India as per the Payment of the Gratuity Act, 1972. Employees who are in continuous service for a period of 5 years are eligible for gratuity. The amount of gratuity payable on retirement/termination is the employees last drawn basic salary per month computed proportionally for 15 days salary multiplied for the number of the years of service upto a maximum of ₹ 1 million.

(i) The assumptions used in accounting for the gratuity plan are set out as below:

Particulars	For the year ended March 31,				
	2019	2018	2017 (Proforma)	2016 (Proforma)	2015 (Proforma)
Future Salary rise	7.00%	7.00%	7.00%	7.00%	7.00%
Discount rate	7.75%	7.75%	7.50%	7.50%	7.50%
Mortality	IALM 2006-08 Ultimate	IALM 2006-08 Ultimate	IALM 2006-08 Ultimate	IALM 2006-08 Ultimate	IALM 2006-08 Ultimate
Withdrawal rate	5%	5%	5%	5%	5%

The estimates of future salary increase, considered in actuarial valuation, take account of inflation, seniority, promotions and other relevant factors such as supply and demand in the employment market. The Company evaluates these assumptions annually based on its long term plans of growth and industry standard.

(ii) The components of gratuity cost recognised in the statement of profit and loss consist of the following:

Particulars	For the year ended March 31,				
	2019	2018	2017 (Proforma)	2016 (Proforma)	2015 (Proforma)
Current Service Cost	13.98	22.55	26.88	30.24	15.03
Interest cost	22.58	17.20	16.79	9.25	6.74
<b>Gratuity cost recognised in statement of profit and loss</b>	<b>36.56</b>	<b>39.75</b>	<b>43.67</b>	<b>39.49</b>	<b>21.77</b>

(iii) Details of the employee benefits obligations and plan assets are provided below:

Particulars	As at March 31,				
	2019	2018	2017 (Proforma)	2016 (Proforma)	2015 (Proforma)
Present value of funded obligations	193.14	180.32	221.89	223.94	123.34
Fair value of plan assets	-	-	-	-	-
<b>Net defined benefit liability recognized</b>	<b>193.14</b>	<b>180.32</b>	<b>221.89</b>	<b>223.94</b>	<b>123.34</b>

(iv) Details of changes in the present value of defined benefit obligations are as follows:

Particulars	For the year ended March 31,				
	2019	2018	2017 (Proforma)	2016 (Proforma)	2015 (Proforma)
Defined benefit obligations at the beginning of the year	180.32	221.89	223.93	123.34	89.85
Current service cost	22.58	22.55	26.88	30.24	15.03
Interest Cost	13.98	17.20	16.79	9.25	6.74
Re measurement - Actuarial (gain)/loss on obligation	(23.74)	(81.32)	(42.31)	61.10	11.72
Benefits paid during the year	-	-	(3.40)	-	-
<b>Defined benefit obligations at the end of the period/ year</b>	<b>193.14</b>	<b>180.32</b>	<b>221.89</b>	<b>223.93</b>	<b>123.34</b>

**Annexure VI: Statement of Notes to the Restated Financial Information**  
(Amounts in ₹ lakhs, unless otherwise stated)

**34. Related party disclosures as required under Indian Accounting Standard 24, "Related party disclosure" are given below.**

In accordance with the provisions of Ind AS 24 "Related Party Disclosures" and the Companies Act, 2013, Company's Directors, members of the Company's Management Council and Company Secretary are considered as Key Management Personnel. List of Key Management Personnel of the Company is as below:

**(i) Key Managerial Personnel (KMPs) & Relatives of KMPs**

For the year ended March 31,				
2019	2018	2017	2016	2015
Umesh V Katti	Umesh V Katti	Umesh V Katti	Umesh V Katti	Umesh V Katti
Nikhil U Katti	Nikhil U Katti	Nikhil U Katti	Nikhil U Katti	Nikhil U Katti
Mukesh Kumar	-	Mukesh Kumar	Mukesh Kumar	Mukesh Kumar
Lava R Katti	Lava R Katti	Lava R Katti	Lava R Katti	Lava R Katti
Kush R Katti	Kush R Katti	Kush R Katti	Kush R Katti	Kush R Katti
Sheela Umesh Katti	Sheela Umesh Katti	Sheela Umesh Katti	Sheela Umesh Katti	Sheela Umesh Katti
Sheshagiri Kulkarni	Sheshagiri Kulkarni	Sheshagiri Kulkarni	Sheshagiri Kulkarni	Sheshagiri Kulkarni
Sneha Patil	Sneha Patil	Sneha Patil	Sneha Patil	Sneha Patil
Mallikarjun J Pujar	Mallikarjun J Pujar	Mallikarjun J Pujar	Mallikarjun J Pujar	Mallikarjun J Pujar

The following is a summary of significant related party transactions:

Name of Related Party	As at March 31,				
	2019	2018	2017 (Proforma)	2016 (Proforma)	2015 (Proforma)
<b>Directors Remuneration</b>					
Nikhil Katti	36.00	36.00	34.50	18.00	18.00
Mukesh Kumar	2.25	-	3.00	15.00	15.00
Mallikarjun Pujar	9.00	9.00	8.75	6.00	6.00
Lava Katti	24.00	24.00	23.00	12.00	12.00
Kush Katti	24.00	24.00	23.00	12.00	12.00
<b>Salary</b>					
Sneha Patil	4.20	4.20	4.00	3.00	3.00
Sheshagiri Kulkarni	4.71	4.68	4.60	3.18	3.12
<b>Transportation Expense</b>					
Mallikarjun Pujar			3.13	3.00	
<b>Purchases<sup>(1)</sup></b>					
Nikhil Katti	4.52	0.86	6.65	15.66	8.49
Mallikarjun Pujar	0.39	0.33	-	3.15	4.38
Lava Katti	10.71	2.16	0.09	0.36	6.50
Kush Katti	10.91	22.39	19.77	0.27	10.44
Umesh V. Katti	10.19	26.28	-	-	8.56
Basavaraj V Hagaragi	0.40	0.98	-	-	-
Sheela Umesh Katti	-	-	2.45	-	-
Ramesh Katti	20.54	-	-	-	-
<b>Advances</b>					
Nikhil U Katti	40.78	40.78	-	-	-
Lava R Katti	52.47	52.47	-	-	-
Kush R Katti	57.24	57.24	-	-	-
Mallikarjun Pujar	-	-	-	2.00	-
<b>Lease Security Deposit</b>					
Nikhil Katti	200.00	200.00	200.00	200.00	200.00

<sup>(1)</sup> The purchases made by the Company from the Promoters / Directors pertain to purchase of sugarcane from the agricultural fields owned by such Promoters / Directors.



In accordance with the applicable provisions of the Income Tax Act, 1961, the Company is required to use certain specified methods in assessing that the transactions with the related parties, are carried at an arm's length price and is also required to maintain prescribed information and documents to support such assessment. The appropriate method to be adopted will depend on the nature of transactions / class of transactions, class of associated persons, functions performed and other factors as prescribed. Based on certain internal analysis carried out, management believes that transactions entered into with the related parties were carried out at arms length prices.

**(ii) Associates / Enterprises over which directors and / or their relatives has significant influence**

For the year ended March 31,				
2019	2018	2017	2016	2015
U R Agrofresh Private Limited	U R Agrofresh Private Limited	U R Agrofresh Private Limited	U R Agrofresh Private Limited	U R Agrofresh Private Limited
Vishwaraj Infrastructure Private Limited	Vishwaraj Infrastructure Private Limited	Vishwaraj Infrastructure Private Limited	Vishwaraj Infrastructure Private Limited	Vishwaraj Infrastructure Private Limited
UK27 Hospitality Services (India) Limited	UK27 Hospitality Services (India) Limited	UK27 Hospitality Services (India) Limited	UK27 Hospitality Services (India) Limited	UK27 Hospitality Services (India) Limited
M/s Vishwaraj Developers	M/s Vishwaraj Developers	M/s Vishwaraj Developers	M/s Vishwaraj Developers	M/s Vishwaraj Developers

The following is a summary of significant related transactions with the entities having significant influence

Name of Related Party	As at March 31,				
	2019	2018	2017 (Proforma)	2016 (Proforma)	2015 (Proforma)
<b>UR Agro Fresh Pvt. Ltd.</b>					
Sales	93.46	-	-	-	-
Debtors outstanding	83.46	-	-	-	-
<i>Advances</i>					
Opening Balance o/s	100.00	-	-	-	-
Advance given during the year	225.00	100.00	-	-	-
Closing Balance o/s	335.00	100.00	-	-	-
<b>UK 27 Hospitality Services (India) Ltd.</b>					
Sales	0.47	-	-	-	-
Debtors outstanding	0.22	-	-	-	-
Expenses	0.47	-	-	-	-
Payable Outstanding	0.14	-	-	-	-
<b>M/s. Vishwaraj Developers</b>					
Sales	0.34	-	-	-	-

**Annexure VI: Statement of Notes to the Restated Financial Information**  
(Amounts in ₹ lakhs, unless otherwise stated)

**35. Ind. AS 108 - Operating Segments**

**Information given in accordance with the requirements of Ind-AS 108 on Segment Reporting:**

The company has identified products wise and unit wise segments i.e. Sugar, Co-generation, Distillery, Vinegar & IML at factory site, IML at Yalahanka respectively of Products & Unit based on return and risk. Hence, the same becomes the reportable segments for the Company. Accordingly, the Company has above operating and reportable segment, the disclosure requirements specified in paragraphs 22 to 30 are made. Accordingly, the Company shall present entity-wide disclosures enumerated in paragraphs 32, 33 and 34 of Ind AS 108.

Information about primary business segments for the year ended March 31, 2019

Particulars	Sugar	Co-generation	Distillery	IML	Vinegar Unit	Others	Unallocated	Total
<b>Total Sales</b>	28,153.43	6,858.47	1,708.44	2,589.58	1,202.07	137.16	-	40,649.16
External Sales	23,402.99	2,178.18	1,169.59	2,589.58	1,202.07	137.16	-	30,679.58
Inter- segment Sales	4,750.45	4,680.28	538.85	-	-	-	-	9,969.58
Segment Result	1,116.62	1,604.99	(2,541.98)	2,033.48	911.99	199.78	340.70	3,665.57
Unallocated Corporate Expenditure	-	-	-	-	-	-	1,084.31	1,084.31
Interest expenses	1,558.95	186.17	-	-	-	-	1,946.83	3,691.95
Interest Income	0.74	-	-	-	-	-	55.52	56.26
Profit Before Depreciation & Exceptional Items & Tax	(441.59)	1,418.82	(2,541.98)	2,033.48	911.99	199.78	(2,634.93)	(1,054.43)
Depreciation	774.84	384.46	72.64	18.77	83.56	-	-	1,334.28
Profit Before Exceptional Items & Tax	(1,216.43)	1,034.36	(2,614.63)	2,014.71	828.42	199.78	(2,634.93)	(2,388.71)
Exceptional Items	-	-	-	-	-	-	-	-
Profit Before Tax	(1,216.43)	1,034.36	(2,614.63)	2,014.71	828.42	199.78	(2,634.93)	(2,388.71)
Tax Expenses	-	-	-	-	-	-	(626.72)	(626.72)
Net profit	(1,216.43)	1,034.36	(2,614.63)	2,014.71	828.42	199.78	(2,008.20)	(1,761.99)
<b>Other Information</b>	-	-	-	-	-	-	-	-
Assets	22,984.17	11,644.98	3,184.72	467.70	2,171.93	-	31,501.46	71,954.96
Liabilities	40,865.47	4,800.00	-	-	-	-	26,289.49	71,954.96
Capital expenditure	279.05	291.43	1,126.02	-	91.35	-	-	1,787.85

Information about primary business segments for the year ended March 31, 2018

Particulars	Sugar	Co-generation	Distillery	IML	Vinegar Unit	Others	Unallocated	Total
<b>Total Sales</b>	21,219.96	5,735.37	1,433.55	4,763.59	1,257.58	216.21	-	34,626.27
External Sales	17,199.74	1,600.64	890.54	4,763.59	1,257.58	216.21	-	25,928.30
Inter- segment Sales	4,020.22	4,134.73	543.02	-	-	-	-	8,697.97
Segment Result	1,203.20	358.43	1,004.47	437.54	885.57	603.55	(1,173.95)	3,318.82
Unallocated Corporate Expenditure	-	-	-	-	-	-	-	-
Interest expenses	2,457.41	-	-	-	-	-	(1.62)	2,455.79
Interest Income	370.73	-	-	-	-	-	-	370.73
Profit Before Depreciation & Exceptional Items & Tax	(883.48)	358.43	1,004.47	437.54	885.57	603.55	(1,172.33)	1,233.77
Depreciation	775.01	373.49	45.93	45.44	80.09	-	-	1,319.96
Profit Before Exceptional Items & Tax	(1,658.49)	(15.06)	958.54	392.10	805.48	603.55	(1,172.33)	(86.19)
Exceptional Items	-	-	-	-	-	-	-	-
Profit Before Tax	(1,658.49)	(15.06)	958.54	392.10	805.48	603.55	(1,172.33)	(86.19)
Tax Expenses	-	-	-	-	-	-	(340.47)	(340.47)
Net profit	(1,658.49)	(15.06)	958.54	392.10	805.48	603.55	(831.86)	(426.67)
<b>Other Information</b>								-
Assets	22,668.00	11,353.55	2,326.26	467.70	2,080.58	-	23,522.53	62,418.63
Liabilities	31,442.40	-	-	-	-	-	30,976.23	62,418.63
Capital expenditure	4,102.74	17.17	42.35	262.43	65.53	-	-	4,490.22

Information about primary business segments for the year ended March 31, 2017

Particulars	Sugar	Co-generation	Distillery	IML	Vinegar Unit	Others	Unallocated	Total
<b>Total Sales</b>	25,593.26	4,606.30	4,394.05	4,854.13	714.00	6.30	-	40,168.04
External Sales	21,411.38	1,707.01	3,491.39	4,854.13	714.00	6.30	-	32,184.21
Inter- segment Sales	4,181.88	2,899.29	902.66	-	-	-	-	7,983.83
Segment Result	3,667.80	957.88	197.69	239.06	232.55	6.30	325.33	5,626.61
Unallocated Corporate Expenditure	-	-	-	-	-	-	(936.38)	(936.38)
Interest expenses	2,543.21	13.87	-	-	-	92.41	417.96	3,067.45
Interest Income	159.20	-	-	-	-	416.84	-	576.04
Profit Before Depreciation & Exceptional Items & Tax	1,283.79	944.01	197.69	239.06	232.55	330.73	(936.38)	2,198.81
Depreciation	628.00	372.98	68.88	8.81	74.80	-	-	1,153.47
Profit Before Exceptional Items & Tax	655.79	571.03	128.81	230.25	157.75	330.73	(936.38)	1,045.34

Exceptional Items	-	-	-	-	-	-	-	-
Profit Before Tax	655.79	571.03	128.81	230.25	157.75	330.73	-936.38	1,045.34
Tax Expenses							(439.09)	(439.09)
Net profit	655.79	571.03	128.81	230.25	157.75	330.73	(1,375.47)	606.26
<b>Other Information</b>								
Assets	22,137.93	11,340.02	2,283.90	205.48	2,015.36	-	16,337.30	54,319.99
Liabilities	28,956.92	-	-	-	-	-	25,363.07	54,319.99
Capital expenditure	4,296.09	0.29	124.41	250.09				4,670.88

Information about primary business segments for the year ended March 31, 2016

Particulars	Sugar	Co-generation	Distillery	IML	Vinegar Unit	Others	Unallocated	Total
<b>Total Sales</b>	31,045.06	7,864.74	3,439.49	9,157.98	47.02	38.61		51,592.89
External Sales	25,737.35	2,887.39	2,707.48	9,157.98	47.02	38.61		40,575.83
Inter- segment Sales	5,307.71	4,977.34	732.01	-	-	-		11,017.07
Segment Result	193.01	2,971.83	(175.49)	726.42	115.16	38.61	592.69	4,462.23
Unallocated Corporate Expenditure							(813.21)	(813.21)
Interest expenses	1,791.78	181.55	-	-	-	-	193.73	2,167.06
Interest Income	379.72	-	-	-	-	-	-	379.72
Profit Before Depreciation & Exceptional Items & Tax	(1,219.05)	2,790.28	(175.49)	726.42	115.16	38.61	(414.25)	1,861.69
Depreciation	613.80	369.81	68.73	8.81	72.81	-		1,133.96
Profit Before Exceptional Items & Tax	(1,832.85)	2,420.47	(244.22)	717.61	42.35	38.61	(414.25)	727.73
Exceptional Items	-	-	-	-	-	-	-	-
Profit Before Tax	(1,832.85)	2,420.47	(244.22)	717.61	42.35	38.61	(414.25)	727.73
Tax Expenses	-	-	-	-	-	-	(642.38)	(642.38)
Net profit	(1,832.85)	2,420.47	(244.22)	717.61	42.35	38.61	(1,056.63)	85.34
<b>Other Information</b>								
Assets	17,951.60	11,339.72	2,252.70	205.48	1,922.15	-	25,226.88	58,898.54
Liabilities	32,536.50	900.00	-	-	-	-	25,462.04	58,898.54
Capital expenditure	726.77	173.21	79.70					979.68

Information about primary business segments for the year ended March 31, 2015

Particulars	Sugar	Co-generation	Distillery	IML	IML Yalahanka	Others	Unallocated	Total
<b>Total Sales</b>	23,984.80	8,630.88	3,523.27	8,732.71	233.23	2.87	-	45,107.75
External Sales	19,158.81	3,618.93	2,761.82	8,732.71	233.23	2.87	-	34,508.36
Inter- segment Sales	4,825.99	5,011.95	761.45	-	-	-	-	10,599.39
Segment Result	(1,788.62)	3,830.48	(262.47)	634.43	60.59	2.87	687.42	3,164.69
Unallocated Corporate Expenditure	-	-	-	-	-	-	557.15	557.15
Interest expenses	-	-	-	-	-	-	2,535.95	2,535.95
Interest Income	-	-	-	-	-	-	926.97	926.97
Profit Before Depreciation & Exceptional Items & Tax	(1,788.62)	3,830.48	(262.47)	634.43	60.59	2.87	(1,478.71)	998.56
Depreciation	530.83	366.37	105.36	8.77	-	-	-	1,011.33
Profit Before Exceptional Items & Tax	(2,319.45)	3,464.11	(367.83)	625.66	60.59	2.87	(1,478.71)	(12.77)
Exceptional Items	-	-	-	-	-	-	-	-
Profit Before Tax	(2,319.45)	3,464.11	(367.83)	625.66	60.59	2.87	(1,478.71)	(12.77)
Tax Expenses	-	-	-	-	-	-	(44.92)	(44.92)
Net profit	(2,319.45)	3,464.11	(367.83)	625.66	60.59	2.87	(1,523.63)	(57.69)
<b>Other Information</b>								
Assets	17,245.68	11,166.51	2,206.07	205.48	-	-	29,677.45	60,501.20
Liabilities	32,507.76	2,000.00	-	-	10.12	-	25,983.32	60,501.20
Capital expenditure	5,262.39	14.09	2,085.53	-	-	-	-	7,362.01

**Annexure VI: Statement of Notes to the Restated Financial Information**  
(Amounts in ₹ lakhs, unless otherwise stated)

**36. Financial instruments - Fair values and risk management**

**Fair value measurements**

Particulars	For the year ended March 31,									
	2019		2018		2017 (Proforma)		2016 (Proforma)		2015 (Proforma)	
	FVTPL	Amortised Cost	FVTPL	Amortised Cost	FVTPL	Amortised Cost	FVTPL	Amortised Cost	FVTPL	Amortised Cost
<b>Financial assets</b>										
Investments	108.24	-	53.24	-	37.98	-	37.65	-	37.65	-
Loans	-	-	-	-	-	-	-	-	-	-
Trade Receivables	3,835.87	-	3,388.06	-	4,435.59	-	1,857.18	-	1,249.79	-
Cash & Cash Equivalents	169.35	-	671.02	-	1,242.07	-	5,135.81	-	1,977.55	-
Bank Balances other than cash & cash Equivalents	15.00	-	74.70	-	31.58	-	29.13	-	14.88	-
Other Financial Assets	219.06	-	218.05	-	278.42	-	307.82	-	265.40	-
<b>Financial Liabilities</b>										
Borrowings	-	31,933.58	-	30,168.56	-	22,665.63	-	24,723.93	-	22,835.83
Trade Payables	11,271.89	-	2,686.39	-	1,434.36	-	2,694.25	-	5,561.88	-
Other Financial Liabilities	3,709.87	-	2,417.46	-	2,046.84	-	4,353.25	-	3,914.01	-

The management considers that the carrying amount of financial assets and financial liabilities carried at amortised cost approximates their fair value.

**Financial Risk Management**

The Company's activities expose it to a variety of financial risks, including credit risk and Market risk. The Company's risk management assessment and policies and processes are established to identify and analyze the risks faced by the Company, to set appropriate risk limits and controls, and to monitor such risks and compliance with the same. Risk assessment and management policies and processes are reviewed regularly to reflect changes in market conditions and the Company's activities. The Board of Directors, risk management committee and the Audit Committee is responsible for overseeing the Company's risk assessment and management policies and processes.

**Credit Risks**

Credit risk is the risk of financial loss to the Company if a customer or counterparty to a financial instrument fails to meet its contractual obligations, and arises principally from the Company's receivables from customers and investment securities. Credit risk is managed through credit approvals, establishing credit limits and continuously monitoring the



---

creditworthiness of customers to which the Company grants credit terms in the normal course of business. The Company establishes an allowance for doubtful debts and impairment that represents its estimate of expected losses in respect of trade and other receivables.

***Trade and Other Receivables***

The Company uses Expected Credit Loss (ECL) model for assessing the impairment loss on trade and other receivables. For this purpose, the Company uses a provision matrix to compute the expected credit loss amount for trade receivables. The provision matrix takes into account external and internal credit risk factors and historical data of credit losses from various customers. The management believes that there is no change in allowance for credit losses for the periods presented.

***Financial assets that are neither past due nor impaired***

None of the Company's cash equivalents, including term deposits (i.e., certificates of deposit) were past due or impaired for the periods presented. The Company's credit period for customers generally ranges from 30 - 90 days.

**Market Risks:**

Market risk is the risk of loss of future earnings, fair values or future cash flows that may result from adverse changes in market rates and prices (such as interest rates, foreign currency exchange rates and commodity prices) or in the price of market risk-sensitive instruments as a result of such adverse changes in market rates and prices. Market risk is attributable to all market risk-sensitive financial instruments, all foreign currency receivables and payables and all short-term and long-term borrowings. The Company is exposed to market risk primarily related to foreign exchange rate risk and interest rate risk. Thus, the Company's exposure to market risk is a function of investing and borrowing activities and revenue generating and operating activities in foreign currencies.

**Interest Rate Risk**

Interest rate risk is the risk that the fair value or future cash flows of a financial instrument will fluctuate because of changes in market interest rates. The Company's fixed rate borrowings are carried at amortised cost. They are therefore not subject to interest rate risk as defined in Ind AS 107, since neither the carrying amount nor the future cash flows will fluctuate because of a change in market interest rates. Further, the Company's investments in deposits are with banks and electricity authorities and therefore do not expose the Company to significant interest rates risk. The Company's variable rate borrowing is subject to interest rate risk.

## **Annexure VII: Statement of First Time Adoption of Ind AS and Adjustments to the Audited Financial Statements**

**(Amounts in ₹ lakhs, unless otherwise stated)**

The Company's Financial Statements for the period ended March 31, 2018, were the first financial statements that have been prepared in accordance with Ind AS. The accounting policies set out in note 1 have been applied in preparing the financial statements for the year ended March 31, 2018, the comparative information presented in these financial statements for the year ended March 31, 2017 and in the preparation of an opening Ind AS balance sheet at April 01, 2016 (the date of transition). In preparing its opening Ind AS balance sheet, the Company has adjusted the amounts reported previously in financial statements prepared in accordance with the accounting standards notified under Companies (Accounting Standards) Rules, 2006 (as amended) and other relevant provisions of the Act (previous GAAP or Indian GAAP). An explanation of how the transition from previous GAAP to Ind AS has affected the Company's financial position, financial performance and Cash flow is given below:

### (i) Optional Exemptions Availed

- *Business combinations*

The Company has availed the business combination exemption on first time adoption of Ind AS and accordingly the business combinations prior to date of transition have not been restated to the accounting prescribed under Ind AS 103 – Business combinations. The Company applies the requirements of Ind AS 103 – Business combinations to business combinations occurring after the date of transition to Ind AS

- *Deemed cost*

Since, there is no change in the functional currency of the Company, it has opted to continue with the carrying values measured under the previous GAAP and use that carrying value as the deemed cost for property, plant and equipment, other intangible assets and investment properties on the date of transition.

- *Leases*

Appendix C to Ind AS 17, Leases, requires an entity to assess whether a contract or arrangement contains a lease. As per Ind AS 17, this assessment should be carried out at inception of the contract or arrangement. However, Company has used Ind AS 101 exemption and assessed all arrangements based for embedded leases based on conditions in place as at the date of transition.

- *Designation of previously recognised financial instruments*

Ind AS 101 allows an entity to designate investments in equity instruments at FVTPL on the basis of the facts and circumstances at the date of transition to Ind ASs. Company has elected to apply this exemption for its investment in equity instruments.

### (ii) Mandatory exceptions applied

- *Estimates*

The estimates as at April 01, 2016 and March 31, 2017 are consistent with those made for the same dates in accordance with previous GAAP (after adjustment to reflect differences if any, in accounting policies) apart from the following items where the application of previous GAAP did not require estimation:

- ❖ Impairment of financial assets based on the expected credit loss model; and
- ❖ Investments in equity instruments carried as FVPL or FVOCI.

The estimates used by the Company to present the amounts in accordance with Ind AS reflect conditions that existed at the date on transition to Ind AS.

- *De-recognition of financial assets and liabilities*

Ind AS 101 requires a first-time adopter to apply the de-recognition provisions of Ind AS 109 prospectively for transactions occurring on or after the date of transition to Ind AS. However, Ind AS 101 allows a first-time adopter to apply the de-recognition requirements in Ind AS 109 retrospectively from a date of the entity's choosing, provided that the information needed to apply Ind AS 109 to financial assets and financial liabilities

derecognised as a result of past transactions was obtained at the time of initially accounting for those transactions. The Company has applied the de-recognition provisions of Ind AS 109 prospectively from the date of transition to Ind AS.

- *Classification and measurement of financial assets*

Ind AS 101 requires an entity to assess classification and measurement of financial assets on the basis of the facts and circumstances that exist at the date of transition to Ind AS.

#### Reconciliation of Equity between Ind AS and Previous GAAP

Particulars	As at March 31,		
	2017	2016	2015
<b>Equity under erstwhile Indian GAAP</b>	24,416.56	23,538.68	23,514.09
Change due to Restatement Adjustment	-	-	-
Impairment of Trade Receivables under ECL Method	(156.62)	(109.92)	(66.73)
Fair Value of defined benefit obligation	(3.98)	(6.63)	(10.23)
Finance cost de-recognised based on effective interest cost	1.91	8.99	4.11
Deferred tax benefit	(1,009.08)	(821.86)	(451.82)
De-recognition of Proposed Dividend (Dividend and Dividend distribution tax)	-	-	-
<b>Equity under Ind AS</b>	<b>23,248.79</b>	<b>22,609.26</b>	<b>22,989.42</b>

#### Effect of Ind AS adoption on the statement of profit and loss

Particulars	For the year ended March 31,		
	2017	2016	2015
<b>Net profit under erstwhile Indian GAAP</b>	<b>877.87</b>	<b>441.45</b>	<b>(321.65)</b>
Restatement Adjustments	-	-	-
Impairment of Trade Receivables under ECL Method	(46.70)	(43.19)	(41.47)
Fair Value of defined benefit obligation	(39.66)	64.70	2.93
Finance cost recognised based on effective interest cost	(7.09)	4.88	4.11
Re-classification of actuarial loss on defined employee benefit obligations	-	-	-
Deferred tax impact	(187.21)	(370.04)	300.63
<b>Net profit for the period under Ind AS</b>	<b>597.22</b>	<b>97.80</b>	<b>(55.45)</b>
Other comprehensive income	42.31	(61.10)	(11.72)
<b>Total comprehensive income</b>	<b>639.53</b>	<b>36.71</b>	<b>(67.17)</b>

#### Prior Period Restatements

The company has adopted Ind AS for the first time in respect of the Audited Financial Statements prepared for the year ending March 31, 2018. There were some omissions in relation to certain items in the Financial Statements as on the Ind AS transition date i.e. April 01, 2017. As per Ind AS 8 prior period errors can be corrected retrospectively in the first set of financial statements approved for issue after the discovery of the error by restating the comparative amounts for the prior period(s) presented in which the error occurred i.e., March 31, 2018; or if the error occurred before the earliest prior period presented, restating the opening balances of assets, liabilities and equity for the earliest prior period presented i.e. April 01, 2017. The following were the details regarding amount of correction made for the opening equity, assets and liabilities of the earliest period presented i.e. April 01, 2017 and for the year ended March 31, 2018 and its impact on Net Profit reported and Other Equity.

#### Reconciliation of Equity between Restated and Previous Reported

Particulars	As at March 31,	
	2018	2017
<b>Equity as per Audited</b>	24,103.72	24,416.56
Impairment of Trade Receivables under ECL Method	(400.35)	(156.62)

Fair Value of defined benefit obligation	130.67	(3.98)
Finance cost de-recognised based on effective interest cost	0.29	1.91
Deferred tax benefit	(942.37)	(1,009.08)
<b>Restated Equity</b>	<b>22,887.95</b>	<b>23,248.79</b>

**Effect on Profit and Loss Account due to restatement of Prior period errors**

<b>Particulars</b>	<b>Year ended March 31, 2018</b>
<b>Net profit as per Audited</b>	<b>(312.87)</b>
Impairment of Trade Receivables under ECL Method	(243.73)
Fair Value of defined benefit obligation	53.33
Finance cost recognised based on effective interest cost	(1.62)
Deferred tax impact	62.71
<b>Restated Net profit for the period</b>	<b>(442.17)</b>
Other comprehensive income	81.32
<b>Total Restated comprehensive income</b>	<b>(360.85)</b>

**Annexure – VIII: Statement of Tax Shelter  
(Amounts in ₹ lakhs, unless otherwise stated)**

Particulars	For the year ended March 31,				
	2019	2018	2017 (Proforma)	2016 (Proforma)	2015 (Proforma)
<b>NORMAL TAX</b>					
Income Tax Rate (%)	33.06%	33.06%	33.06%	33.06%	32.45%
<b>Restated Income before tax as per books (A)</b>	<b>(2,388.72)</b>	<b>(86.20)</b>	<b>1,045.34</b>	<b>727.73</b>	<b>(12.77)</b>
<b>Incomes considered separately</b>					
Dividend and other income	3.41	3.40	4.30	0.02	0.03
<b>Total Incomes considered separately (B)</b>	<b>3.41</b>	<b>3.40</b>	<b>4.30</b>	<b>0.02</b>	<b>0.03</b>
<b>Restated Profit other than income considered separately (C)=(A-B)</b>	<b>(2,392.13)</b>	<b>(89.60)</b>	<b>1,041.04</b>	<b>727.71</b>	<b>(12.80)</b>
<b>Tax Adjustment</b>					
<b>Permanent Differences</b>					
Section 40 Disallowance	-	39.96	15.78	-	52.62
Section 43B Disallowance	-	-	132.85	261.56	343.60
Section 37 Disallowance (Including Deferment of Processing charges & Impairment of Trade receivables)	263.04	261.55	59.81	38.36	81.22
Section 40A disallowance	21.45	93.08	4.02	104.19	24.69
Section 36 Disallowance	-	-	10.46	-	-
Loss on sale of Vehicles	-	-	-	-	-
Donation	-	-	-	-	-
Other Deductions	-	779.80	1,220.44	-	-
<b>Total Permanent Differences (D)</b>	<b>284.49</b>	<b>1,174.39</b>	<b>1,443.36</b>	<b>404.11</b>	<b>502.13</b>
<b>Timing Differences</b>					
Book Depreciation	1,334.28	1,319.96	1,153.47	1,133.96	1,011.33
Income Tax Depreciation allowance	2,180.96	2,586.39	2,035.83	2,246.31	2,415.83
<b>Total Timing Differences (E)</b>	<b>(846.68)</b>	<b>(1,266.43)</b>	<b>(882.35)</b>	<b>(1,112.35)</b>	<b>(1,404.50)</b>
<b>Income From Business or Profession (F)=(C+D+E)</b>	<b>(2,954.32)</b>	<b>(181.64)</b>	<b>1,602.04</b>	<b>19.47</b>	<b>(915.16)</b>
<b>Income From Other Sources (G)</b>					
Dividend	3.41	3.40	4.30	0.02	0.03
<b>Taxable income from other sources (G)</b>	<b>3.41</b>	<b>3.40</b>	<b>4.30</b>	<b>0.02</b>	<b>0.03</b>
<b>Taxable Income/(Loss) (F+G)</b>	<b>(2,950.91)</b>	<b>(178.23)</b>	<b>1,606.34</b>	<b>19.49</b>	<b>(915.13)</b>
Unabsorbed Losses	2,950.91	178.23	(895.64)	(19.49)	915.13
<b>Gross Total Income</b>	<b>-</b>	<b>-</b>	<b>710.69</b>	<b>-</b>	<b>-</b>
<b>Deductions under chapter VI-A</b>					
80IA Infrastructure development and 80G Donations	-	-	(514.35)	-	-
<b>Taxable Income</b>	<b>-</b>	<b>-</b>	<b>196.34</b>	<b>-</b>	<b>-</b>
<b>Tax on Total Income</b>	<b>-</b>	<b>-</b>	<b>64.91</b>	<b>-</b>	<b>-</b>
<b>MINIMUM ALTERNATE TAX</b>					
Minimum Alternate Tax Rate (%)	21.55%	19.06%	21.34%	20.39%	19.06%
<b>Restated Income before tax as per books (A)</b>	<b>(2,689.04)</b>	<b>(139.53)</b>	<b>1,045.34</b>	<b>727.73</b>	<b>(12.77)</b>
Add: Income Tax Paid	-	-	-	-	-
<b>Book Profit u/s 115JB</b>	<b>(2,689.04)</b>	<b>(139.53)</b>	<b>1,045.34</b>	<b>727.73</b>	<b>(12.77)</b>
<b>MAT on Book Profit</b>	<b>MAT</b>	<b>MAT</b>	<b>MAT</b>	<b>MAT</b>	<b>MAT</b>
Tax paid as per normal or MAT	-	-	223.09	148.37	-
Total Tax as per Return	-	21.58	243.03	143.00	4.13
Diff	-	(21.58)	(19.94)	5.38	(4.13)

**OTHER FINANCIAL INFORMATION**

**RESTATED STATEMENT OF ACCOUNTING RATIOS**

(Amounts in ₹ lakhs, unless otherwise stated)

Particulars	As at March 31,				
	2019	2018	2017	2016	2015
Restated PAT as per P & L Account	(1,761.99)	(426.67)	606.25	85.35	(57.68)
Actual Number of Equity Shares outstanding at the end of the year	34,556,000	34,556,000	34,556,000	34,556,000	34,556,000
Equivalent Weighted Average number of Equity Shares at the end of the year	34,556,000	34,556,000	34,556,000	34,556,000	34,556,000
Share Capital	3,455.60	3,455.60	3,455.60	3,455.60	3,455.60
Reserves & Surplus	17,694.09	19,432.35	19,793.19	19,153.66	19,533.82
Net Worth	21,149.69	22,887.95	23,248.79	22,609.26	22,989.42
<b>Earnings Per Share:</b>					
<b>Basic &amp; Diluted (₹)</b>	<b>(5.10)</b>	<b>(1.23)</b>	<b>1.75</b>	<b>0.25</b>	<b>(0.17)</b>
<b>Return on Net Worth (%)</b>	<b>-8.33%</b>	<b>-1.86%</b>	<b>2.61%</b>	<b>0.38%</b>	<b>-0.25%</b>
<b>Net Asset Value Per Share (₹) - based on actual no. of equity shares at the end of the year</b>	61.20	66.23	67.28	65.43	66.53
Nominal Value per Equity share (₹)	10.00	10.00	10.00	10.00	10.00

**Notes to Accounting Ratios:**

- a) The above statement should be read with the Significant Accounting Policies and Notes to Accounts appearing in Annexure V & VI respectively.
- b) There is no revaluation reserve in last five years in our company.
- c) As there is no dilutive capital in the company, Basic and Diluted EPS are similar.
- d) Formulas used for calculating above ratios are as under:
  - i. Basic EPS is being calculated by using the formula: (Net Profit after excluding Extra-ordinary items / Equivalent Weighted Average No. of outstanding shares)
  - ii. Net Asset Value is being calculated by using the formula: (Net Worth / Actual Number of Equity Shares at year end)
  - iii. Return on Net worth is being calculated by using the formula: (Profit After Tax / Networth)



**CAPITALISATION STATEMENT**

**R RESTATED STATEMENT OF CAPITALISATION**

(Amounts in ₹ lakhs, unless otherwise stated)

Particulars	Pre Issue (as at March 31, 2019)	Post Issue
<b>Borrowings</b>		
Current Borrowings (A)	25,385.68	25,385.68
Non-Current Borrowings (including Current Maturity) (B)	8,493.74	8,493.74
<b>Total Borrowings (C=A+B)</b>	33,879.42	33,879.42
<b>Shareholders' funds</b>		
Equity share capital (D)	3,455.60	[•]
Other Equity - as restated (E)	17,694.09	[•]
<b>Total Equity Capital (F=D+E)</b>	21,149.69	[•]
<b>Non Current Borrowings / Total Equity</b>	0.40	[•]
<b>Total Borrowings / Total Equity</b>	1.60	[•]

**Notes:**

1. The corresponding post IPO capitalisation data for each of the amounts given in the above table is not determinable at this stage pending the completion of the Book Building process and hence the same have not been provided in the Restated Statement of Capitalisation.
2. The amounts disclosed above are based on the Restated Ind AS Financial Information of the Company.

## MANAGEMENT DISCUSSION AND ANALYSIS OF FINANCIAL CONDITION AND RESULTS OF OPERATION

*The following discussion and analysis of our financial condition and results of operations are based on, and should be read in conjunction with the Restated Financial Statements, the notes and significant accounting policies thereto and the Reports thereon included in the section “Financial Statements” beginning on page no. 202 of this Red Herring Prospectus.*

*Our financial statements, as included in this Red Herring Prospectus, for financial year ended March 31, 2019 and March 31, 2018 were prepared in accordance with Ind AS, as notified under the Companies (Indian Accounting Standards) Rules, 2015 read with Section 133 of the Companies Act, 2013 to the extent applicable and complying with the requirements of SEBI ICDR Regulations. Our Financial Statements for the financial year ended March 31, 2017, 2016 and 2015 was prepared in accordance with Indian GAAP, which have been translated into figures as per Ind AS to align accounting policies, exemptions and disclosures as adopted by our Company on its first-time adoption of Ind AS on the transition date and are restated in accordance with requirements of SEBI ICDR Regulations. The restated financials of the Company restated in accordance with SEBI ICDR Regulations, including the schedules, annexures and notes thereto and reports thereon, is included in the section “Financial Statements” beginning on page no. 202 of this Red Herring Prospectus. Ind AS differs in certain material respects from IFRS and U.S. GAAP. We have not attempted to quantify the impact of IFRS or U.S. GAAP on the financial information included in this Red Herring Prospectus, nor do we provide a reconciliation of our financial statements to those under U.S. GAAP or IFRS. Accordingly, the degree to which the financial information included in this Red Herring Prospectus will provide meaningful information depends on the reader’s level of familiarity with the Companies Act, Ind AS and the SEBI ICDR Regulations. Any reliance on the financial disclosure in this Red Herring Prospectus, by persons not familiar with Indian accounting practices, should accordingly be limited.*

*This discussion contains forward-looking statements that involve risks and uncertainties and reflects our current view with respect to future events and financial performance. Actual results may differ from those anticipated in these forward-looking statements as a result of factors such as those set forth under “Risk Factors” on page no. 17 of this Red Herring Prospectus.*

*In this section, a reference to the “Company” means Vishwaraj Sugar Industries Limited. Unless the context otherwise requires, references to “we”, “us”, or “our” refers to Vishwaraj Sugar Industries Limited. Our Company does not have any subsidiaries, joint ventures or associates, and no consolidated financial statements are prepared. Unless otherwise indicated, the financial information included herein is based on the Restated Financial Statements as at and for the Fiscals 2015, 2016, 2017, 2018 and 2019.*

### **BUSINESS OVERVIEW**

We are an integrated sugar and other allied products manufacturing company operating from Belgaum District in the State of Karnataka which is designated as one of the “High Recovery zones” for sugar production by Government of India. We operate a single location sugar unit having licensed crushing capacity of 11,000 TCD. In addition to sugar we also manufacture other allied products like Rectified Spirits, Extra-Neutral Spirits, Indian Made Liquor, Vinegar, Compost, Carbon dioxide (CO<sub>2</sub>), etc. and are further engaged in the generation of Power for captive consumption as well as external sale. Our business can hence be broken up into five main segments namely Sugar, Co-Generation, Distillery, Indian Made Liquor (IML) and Vinegar.

In the year 2001, we commenced operations of manufacture of Distillery products such as Ethanol, Rectified Spirit and Extra Neutral Spirit. In the year 2006, our Company implemented backward integration and began commercial operations for Sugar manufacture from sugarcane, along with Co-Generation capabilities. During the year 2008, we began bottling of Indian Made Liquor. Currently our integrated unit processes sugarcane to produce sugar and the by-products are used to generate electricity for captive use and commercial sale, manufacture rectified spirit, ENA, IML, Vinegar, Press-mud and Compost. Over the years, we have expanded the production / manufacturing capacities of all our products.

During the production of sugar; bagasse and molasses are produced which are the basic raw materials for power generation and Distillery (Spirit) manufacturing unit, respectively. The sugar unit of our integrated production facility first crushes sugarcane to extract juice and processes the juice to produce sugar. The sugar manufactured is then graded and packed based on the size of crystals and quality of the sugarcane. During the last fiscal year we produced 32,170 tonnes of sugar. After extracting the juice from sugarcane, the residual fibre leftover called Bagasse is used as a fuel for power generation. The molasses used in the process of sugar production is fermented and distilled to manufacture

various spirits (Rectified Spirit and Extra Neutral Spirit) and IML in the distillery unit of our integrated production and manufacturing facility.

Bagasse is the fibrous residual matter used as a bio-fuel to generate steam in high pressure boilers for turning turbines to generate electricity. We obtain enough Bagasse during the crushing seasons, such that the electricity produced is used not just for captive consumption, but also for sale. For electricity generated over and above our captive consumption, we have entered into Power Purchase Agreements with 5 electricity distribution companies in Karnataka to supply a total of 22.4 MW. It is possible that during the year we may produce surplus energy and supply the surplus energy to other Companies / Industries based on demand.

Molasses is the viscous product resultant of refining sugarcane juice. Molasses, which forms the primary raw material for the distillery unit, is fermented, distilled and made to undergo various processes for making rectified spirit and extra neutral spirit. Rectified Spirit is processed to manufacture Industrial Vinegar. Extra- Neutral spirit is further processed for manufacture of IML products. The Extra-Neutral spirit is blended to manufacture Whiskey which is sold by us under our various brands like VSL Deluxe Whisky, District-1 and VSL Black. During the last financial year, we manufactured approximately 1,890 boxes of IML, 4,098 KL of Industrial Vinegar, 8,838 KL of Rectified Spirit and 2,269 KL of Extra-Neutral Spirit.

Further the waste water extracted from Distillery unit is called as spentwash which is further mixed with mud to form Compost / Organic Manure, which is supplied back to farmers for cultivation of their fields which ensures higher yields. Further the company has set up a CO2 plant also. Thus, we believe that nothing is wasted, as every single output whether residue or by-product is utilised.

## COMPETITION

India is one of the largest sugar producer and consumer in the world. Our Company faces severe competition in the business of Sugar production from sugar mills operating not only in Karnataka and Maharashtra but throughout the country and also from international markets. Though our direct sugar competitors are the sugar mills operating out of North West Karnataka and South West Maharashtra, with the de-regulation of sugar prices, we now have to set sugar prices as per national competition. The competition faced by us is also in the form of sugarcane purchase from farmers from villages in our vicinity and also outside the area of our factory. Further, competition in the sugar industry arises from organised as well as from un-organised sector.

We face scarce competition in our power generation segment in lieu of existing PPA with 5 electricity supply companies, huge demand from our customers and limited competitors.

Our distillery segment faces stiff competition from domestic players as well as local players with regards to pricing our brands vis-à-vis the other IML and IMFL products. Competition in IML is relatively strong from the un-organised market. The distillery segment being highly price sensitive, we respond to our competitors by pricing our alcoholic products suitably.

### **Significant Developments after March 31, 2019 that may affect our Future Results of Operations**

The Directors confirm that other than the following developments, there have been no events or circumstances since the date of the last financial statements as disclosed in the Red Herring Prospectus which materially or adversely affect or is likely to affect the profitability of our Company, or the value of our assets, or our ability to pay liabilities within next twelve months.

- Our Company has been sanctioned a new term loan from The Belgaum District Central Cooperative Bank Ltd. (BDCC) with a vide sanction letter dated May 29, 2019 for a total sanction amount of ₹ 1,842 lakhs in relation to the GoI Scheme of Soft Loan to Sugar Mills to facilitate payment of cane dues of the farmers for the season of 2018-19.
- Our Company has been sanctioned a new term loan from Bank of India (BoI) with a vide sanction letter dated May 15, 2019 for a total sanction amount of ₹ 985.00 lakhs in relation to the GoI Scheme of Soft Loan to Sugar Mills to facilitate payment of cane dues of the farmers for the season of 2018-19.

## FACTORS AFFECTING OUR RESULT OF OPERATION

Our business is subject to various risks and uncertainties, including those discussed in the section titled “*Risk Factors*” on page no. 17 of this Red Herring Prospectus.

Among various other factors that affect our financial results and operations for a given financial year, some key factors are as follows:

- ***Sugarcane is the principal raw material used for the production of sugar. Our business depends on the availability of sugarcane and any shortage of sugarcane may adversely affect our business and results of operations.***

We purchase our entire sugarcane requirement directly from various independent farmers. After the de-regulation of the sugar sector, the farmers growing sugarcane within the villages around our manufacturing facility are not required to sell the sugarcane to our Company and we need to maintain cordial relations with these farmers to ensure that they sell their produce to us. Also, we strive to maintain relations with farmers in other villages not in our immediate vicinity so that we have adequate supply of sugarcane during the crushing season. Further, the farmers within our reserved area have no legal or contractual obligation to cultivate sugarcane and may instead grow other crops. If the farmers within our reserved area cultivate other crops, or otherwise limit their cultivation of sugarcane, we may have a shortage of the raw material. We work with the farmers to determine the harvesting schedule and also provide them with subsidised seeds, cutting & transport assistance so that these farmers sell their produce to us. However, if the farmers are able to realise a higher price for sales of sugarcane from other sugar factories or other users, the farmer may have an incentive to sell the sugarcane to parties other than us.

Further, farmers may want to harvest the crop earlier than we have scheduled or grow other crops thereby disrupting our operations. To ensure that the farmers stay interested in selling sugarcane to our Company, we may need to provide financial and other incentives to the farmers. Diversion of sugarcane to other users or other sugar factories may reduce the sugarcane available to us and may adversely affect our financial condition and results of operation.

In addition, adverse weather conditions, crop disease, pest attacks may adversely affect sugarcane crop yields and sugar recovery rates for any given harvest. Our sugar production depends on the volume and sucrose content of the sugarcane that is supplied to us. Crop yields and sucrose content depends primarily on the variety of sugarcane grown, the presence of any crop disease, weather conditions such as adequate rainfall and temperature which may vary even in a particular season. Adverse weather conditions may adversely affect our manufacturing operations. Flood or drought can adversely affect the supply and pricing of the sugarcane procured by us from the farmers. There can be no assurance that weather patterns, crop disease or the cultivation of certain sugarcane crop varieties will not reduce the amount of sugar that we can recover in any given harvest. Any reduction in the amount of sugar recovered from sugarcane could have a material adverse effect on our business and results of operations.

- ***We operate in five business segments and our inability to manage our diversified operations may have an adverse effect on our business, results of operations and financial condition.***

We operate in five business segments under our own Company: Sugar, Co-generation, Distillery, IML and Vinegar. Though these business segments are inter-connected, our management requires considerable expertise and skill to manage and allocate an appropriate amount of time, attention and other resources to each segment. Operating such multiple segments also makes forecasting future revenue and operating results difficult, which may impair our operations and your ability to assess our prospects. In addition, our cost controls, internal controls, and accounting and reporting systems must be integrated and upgraded on a continual basis to support our segments. In order to manage and integrate our segments effectively, we will be required to, among other things, stay abreast with key developments in each geography in which we operate, implement and continue to improve our operational, financial and management systems, develop the management skills of our managers and continue to train, motivate and manage our employees. If we are unable to manage our segmental operations, our business, results of operations and financial condition may be adversely affected.

- ***Our business is working capital intensive. If we are unable to generate sufficient cash flows to allow us to make required payments on our debt or fund working capital requirements, there may be an adverse effect on our results of operations.***

Our business is working capital intensive including fund requirement for payment for sugarcane purchase during the crushing season. Hence, major portion of our working capital is utilised towards debtors and inventory. Our debtors for

the F. Y. 2018-19, 2017-18 and 2016-17 was 18.14%, 14.80%, and 19.08% of the total net worth respectively in each year. Our inventories F. Y. 2018-19, 2017-18 and 2016-17 was 153.36%, 114.28%, and 78.28% of the total net worth respectively in each year.

The results of operations of our business are dependent on our ability to effectively manage our inventory (raw material and finished goods) and trade receivables. To effectively manage our inventory, we must be able to accurately estimate customer demand and supply requirements and purchase new inventory accordingly. However, if our management misjudges expected customer demand, it could cause either a shortage of products or an accumulation of excess inventory. Further, if we fail to sell the inventory we produce / manufacture or purchase, we may be required to write-down our inventory or pay our suppliers without new purchases, or create additional vendor financing, all of which could have an adverse impact on our income and cash flows. To effectively manage our trade receivables, we must be able to accurately evaluate the credit worthiness of our customers and dealers and ensure that suitable terms and conditions are given to them in order to ensure our continued relationship with them. However, if our management fails to accurately evaluate the credit worthiness of our customers, it may lead to bad debts, delays in recoveries and / or write-offs which could lead to a liquidity crunch, thereby adversely affecting our business and results of operations. A liquidity crunch may also result in increased working capital borrowings and, consequently, higher finance cost which will adversely impact our profitability.

We have a sanctioned limit for working capital of ₹ 26,500 lakhs from the existing bankers / financial institutions. Our inability to maintain sufficient cash flow, credit facility and other sourcing of funding, in a timely manner, or at all, to meet the requirement of working capital or pay out debts, could adversely affect our financial condition and result of our operations. In the event we are not able to recover our dues from our trade receivables or utilise / sell our inventory, we may not be able to maintain our Sales level and thus adversely affecting our financial health. If this situation persists, we may not be able to pay our lenders / creditors and we may be forced to go for Corporate Debt Restructuring (CDR) which may result in adversely affecting our operations and future prospects.

➤ ***We have incurred substantial indebtedness which exposes us to various risks which may have an adverse effect on our business and results of operations. We may also be unable to obtain future financing to fund our operations, expected capital expenditure and working capital requirements on favourable terms, or at all.***

As of March 31, 2019 and March 31, 2018, we have ₹ 33,879.42 lakhs and ₹ 31,464.03 lakhs (including current maturities of long term debt but excluding non fund based) respectively, of outstanding debt on our balance sheet. Our level of indebtedness has important consequences to us, such as:

- increasing our vulnerability to general adverse economic, industry and competitive conditions;
- limiting our flexibility in planning for, or reacting to, changes in our business and the industry;
- affecting our credit rating;
- limiting our ability to borrow more money both now and in the future; and
- increasing our interest expenditure and adversely affecting our profitability, since almost all of our debt bears interest at floating rates.

If any of these risks were to materialise, our business and results of operations may be adversely affected. Our business requires funding for capital expenditure and working capital requirements. The actual amount and timing of future capital expenditure may depend on several factors, among others, new opportunities, availability of land, regulatory approvals, regulatory changes, economic conditions, technological changes and market developments in our industry. Our sources of additional funding, if required, to meet our capital expenditure may include the incurrence of debt or the issue of equity or debt securities or a combination of both. If we decide to raise additional funds through the incurrence of debt, our interest and debt repayment obligations will increase, and could have a significant effect on our profitability and cash flows and we may be subject to additional covenants, which could limit our ability to access cash flows from operations. In case there is insufficient cash flow to meet our working capital requirement or we are unable to arrange the same from other sources or there is delay in disbursement of arranged funds, or there is any increase in interest rate on our borrowings, it may adversely affect our operations and profitability. These factors may result in an increased amount of short-term borrowings. Continuous increase of our working capital requirements may have an adverse effect on our results of operations and financial condition.

Further our ability to arrange for additional funds on acceptable terms is subject to a variety of uncertainties, including future results of operations, financial condition and cash flows; economic, political conditions and market scenario for our products; costs of financing, liquidity and overall condition of financial and capital markets in India; issuance of necessary business/government licenses, approvals and other risks associated with our businesses; and limitations on our ability to raise capital in capital markets and conditions of the Indian and other capital markets in which we may

seek to raise funds. Any such inability to raise sufficient funds could have a material adverse effect on our business and results of operations.

➤ ***Our business is subject to seasonal variations that could result in fluctuations in our results of operations.***

Our business is seasonal in nature and as a result, our operating results may fluctuate. Since our business is influenced by the availability of our basic raw material, i.e. sugarcane, our production schedules are operational only according to such availability. For example, Belgaum area, the crushing season generally starts from October each year and remains till April. It is during this period that our majority of the sugar production takes place. During the non-crushing season, i.e. May to September, not only is our sugar production affected but also our co-generation and distillery units are affected for the lack of bagasse and molasses. Further, other seasonal factors such as irrigation, seed quality, area of sugarcane production and amount of rainfall also play a role in determining the quantity and quality of sugarcane produce. Consequently, the results of one reporting period may not be necessarily comparable with the preceding, succeeding or corresponding reporting periods. Our revenues recorded during planting and harvesting seasons (i.e. 1<sup>st</sup> half of any financial year) are typically lower or even in losses as compared to revenues recorded during the crushing season (i.e. 2<sup>nd</sup> half of the financial year). During periods of lower sugar production, we continue to incur substantial operating expenses in connection with day to day operations, employees' salaries, miscellaneous maintenance cost and among other things, product promotion expenses which are not reduced significantly during such periods, while our revenues remain reduced.

We have experienced, and expect to continue to experience, significant variability in our total revenue, operating cash flows, operating expenses and net revenues on a seasonal basis. Accordingly, our financial year ended March 31, 2019 has reported a loss of ₹ 1,761.99 lakhs. However, with the increase in sugar prices in the 1<sup>st</sup> quarter of the current financial year, we believe that we may experience better revenues, operating cash flows, etc. in the forthcoming financial years.

For more details, see “*Risk Factors*” and “*Our Business*”, on page nos. 17 and 130, respectively of this Red Herring Prospectus.

## **Revenue and Expenses**

The major component of our Revenue and Expenditure is as below:

*Revenue:* Total revenue consists of revenue from operations and other income.

Revenue from operations: Revenue from operations consists of income from the following segments:

- a. Sugar Segment
- b. Power
- c. Ethanol, Spirit and allied Products (Distillery Segment)
- d. IML
- e. Vinegar
- f. Other By-Products

*Other Income:* Other income includes dividend income, rental income, profits from sale of income, insurance claims and insurance income.

*Expenses:* Expenses consists of cost of material consumed, changes in inventories, other manufacturing expenses, employee benefit expenses, finance costs, depreciation and other expenses.

*Cost of Material Consumed:* Cost of raw materials includes purchase of sugarcane, cane cess and tax, harvesting and transport costs, purchase of raw sugar, consumption of power and fuel, purchase of stores, spares and chemicals.

*Changes in inventories:* Consists of changes in raw materials, work-in-progress and finished products. Raw materials consist of coal, molasses and bagasse. Finished goods consist of sugar, vinegar, IML and other by-products.

*Other manufacturing expenses:* Other manufacturing expenses consist of Processing, transportation and other charges and Repairs to Plant and Machinery.



*Employee benefit expenses:* Employee benefit expenses comprises of salaries and wages paid to employees and workers, bonuses, contribution to provident and other funds, staff welfare expenses and director's remuneration.

*Finance Cost:* Finance cost includes interest expenses and other borrowing costs such as commission and charges by banks, loan processing charges, Letter of Credit charges and Bank rating charges.

*Depreciation and Amortization expenses:* Depreciation and amortization expenses comprises of depreciation on tangible assets and amortization of intangible assets.

*Other expenses:* Other expenses include rent, advertisement expenses, insurance, travelling expenses, vehicle running and maintenance, printing and stationery, communication expenses, legal, professional and consultancy charges, license fees and other miscellaneous expenses.

## Segment Reporting

The following tables set forth our segment information for the periods indicated:

### SEGMENT INFORMATION FOR THE YEAR ENDED MARCH 31, 2019 AS PER IND AS – 108

(₹ in lakhs)

Particulars	Sugar	Co-generation	Distillery	IML	Vinegar Unit	Others	Unallocated	Total
<b>Total Sales</b>	28,153.43	6,858.47	1,708.44	2,589.58	1,202.07	137.16	-	40,649.16
External Sales	23,402.99	2,178.18	1,169.59	2,589.58	1,202.07	137.16	-	30,679.58
Inter- segment Sales	4,750.45	4,680.28	538.85	-	-	-	-	9,969.58
Segment Result	1,116.62	1,604.99	(2,541.98)	2,033.48	911.99	199.78	340.70	3,665.57
Unallocated Corporate Expenditure	-	-	-	-	-	-	1,084.31	1,084.31
Interest expenses	1,558.95	186.17	-	-	-	-	1,946.83	3,691.95
Interest Income	0.74	-	-	-	-	-	55.52	56.26
Profit Before Depreciation & Exceptional Items & Tax	(441.59)	1,418.82	(2,541.98)	2,033.48	911.99	199.78	(2,634.93)	(1,054.43)
Depreciation	774.84	384.46	72.64	18.77	83.56	-	-	1,334.28
Profit Before Exceptional Items & Tax	(1,216.43)	1,034.36	(2,614.63)	2,014.71	828.42	199.78	(2,634.93)	(2,388.71)
Exceptional Items	-	-	-	-	-	-	-	-
Profit Before Tax	(1,216.43)	1,034.36	(2,614.63)	2,014.71	828.42	199.78	(2,634.93)	(2,388.71)
Tax Expenses	-	-	-	-	-	-	(626.72)	(626.72)
Net profit	(1,216.43)	1,034.36	(2,614.63)	2,014.71	828.42	199.78	(2,008.20)	(1,761.99)
<b>Other Information</b>	-	-	-	-	-	-	-	-
Assets	22,984.17	11,644.98	3,184.72	467.70	2,171.93	-	31,501.46	71,954.96
Liabilities	40,865.47	4,800.00	-	-	-	-	26,289.49	71,954.96
Capital expenditure	279.05	291.43	1,126.02	-	91.35	-	-	1,787.85

### SEGMENT INFORMATION FOR THE YEAR ENDED MARCH 31, 2018 AS PER IND AS – 108

(₹ in lakhs)

Particulars	Sugar	Co-generation	Distillery	IML	Vinegar Unit	Others	Unallocated	Total
<b>Total Sales</b>	21,219.96	5,735.37	1,433.55	4,763.59	1,257.58	216.21	-	34,626.27
External Sales	17,199.74	1,600.64	890.54	4,763.59	1,257.58	216.21	-	25,928.30
Inter- segment Sales	4,020.22	4,134.73	543.02	-	-	-	-	8,697.97
Segment Result	1,203.20	358.43	1,004.47	437.54	885.57	603.55	(1,173.95)	3,318.82
Unallocated Corporate Expenditure	-	-	-	-	-	-	-	-
Interest expenses	2,457.41	-	-	-	-	-	(1.62)	2,455.79
Interest Income	370.73	-	-	-	-	-	-	370.73

Profit Before Depreciation & Exceptional Items & Tax	(883.48)	358.43	1,004.47	437.54	885.57	603.55	(1,172.33)	1,233.77
Depreciation	775.01	373.49	45.93	45.44	80.09	-	-	1,319.96
Profit Before Exceptional Items & Tax	(1,658.49)	(15.06)	958.54	392.10	805.48	603.55	(1,172.33)	(86.19)
Exceptional Items	-	-	-	-	-	-	-	-
Profit Before Tax	(1,658.49)	(15.06)	958.54	392.10	805.48	603.55	(1,172.33)	(86.19)
Tax Expenses	-	-	-	-	-	-	(340.47)	(340.47)
Net profit	(1,658.49)	(15.06)	958.54	392.10	805.48	603.55	(831.86)	(426.67)
<b>Other Information</b>								-
Assets	22,668.00	11,353.55	2,326.26	467.70	2,080.58	-	23,522.53	62,418.63
Liabilities	31,442.40	-	-	-	-	-	30,976.23	62,418.63
Capital expenditure	4,102.74	17.17	42.35	262.43	65.53	-	-	4,490.22

**SEGMENT INFORMATION FOR THE YEAR ENDED MARCH 31, 2017 AS PER IND AS – 108**
*(₹ in lakhs)*

Particulars	Sugar	Co-generation	Distillery	IML	Vinegar Unit	Others	Unallocated	Total
<b>Total Sales</b>	25,593.26	4,606.30	4,394.05	4,854.13	714.00	6.30		40,168.04
External Sales	21,411.38	1,707.01	3,491.39	4,854.13	714.00	6.30	.	32,184.21
Inter- segment Sales	4,181.88	2,899.29	902.66	-	-	-		7,983.83
Segment Result	3,667.80	957.88	197.69	239.06	232.55	6.30	325.33	5,626.61
Unallocated Corporate Expenditure							(936.38)	(936.38)
Interest expenses	2,543.21	13.87	-	-	-	92.41	417.96	3,067.45
Interest Income	159.20					416.84		576.04
Profit Before Depreciation & Exceptional Items & Tax	1,283.79	944.01	197.69	239.06	232.55	330.73	(936.38)	2,198.81
Depreciation	628.00	372.98	68.88	8.81	74.80	-		1,153.47
Profit Before Exceptional Items & Tax	655.79	571.03	128.81	230.25	157.75	330.73	(936.38)	1,045.34
Exceptional Items	-	-	-	-	-	-	-	-
Profit Before Tax	655.79	571.03	128.81	230.25	157.75	330.73	-936.38	1,045.34
Tax Expenses							(439.09)	(439.09)
Net profit	655.79	571.03	128.81	230.25	157.75	330.73	(1,375.47)	606.26
<b>Other Information</b>								
Assets	22,137.93	11,340.02	2,283.90	205.48	2,015.36	-	16,337.30	54,319.99
Liabilities	28,956.92	-	-	-	-	-	25,363.07	54,319.99
Capital expenditure	4,296.09	0.29	124.41	250.09				4,670.88

**SEGMENT INFORMATION FOR THE YEAR ENDED MARCH 31, 2016 AS PER IND AS – 108**
*(₹ in lakhs)*

Particulars	Sugar	Co-generation	Distillery	IML	Vinegar Unit	Others	Unallocated	Total
<b>Total Sales</b>	31,045.06	7,864.74	3,439.49	9,157.98	47.02	38.61		51,592.89
External Sales	25,737.35	2,887.39	2,707.48	9,157.98	47.02	38.61		40,575.83
Inter- segment Sales	5,307.71	4,977.34	732.01	-	-	-		11,017.07
Segment Result	193.01	2,971.83	(175.49)	726.42	115.16	38.61	592.69	4,462.23
Unallocated Corporate Expenditure							(813.21)	(813.21)
Interest expenses	1,791.78	181.55	-	-	-	-	193.73	2,167.06
Interest Income	379.72	-	-	-	-	-	-	379.72
Profit Before Depreciation & Exceptional Items & Tax	(1,219.05)	2,790.28	(175.49)	726.42	115.16	38.61	(414.25)	1,861.69
Depreciation	613.80	369.81	68.73	8.81	72.81	-		1,133.96
Profit Before Exceptional Items & Tax	(1,832.85)	2,420.47	(244.22)	717.61	42.35	38.61	(414.25)	727.73
Exceptional Items	-	-	-	-	-	-	-	-
Profit Before Tax	(1,832.85)	2,420.47	(244.22)	717.61	42.35	38.61	(414.25)	727.73
Tax Expenses	-	-	-	-	-	-	(642.38)	(642.38)
Net profit	(1,832.85)	2,420.47	(244.22)	717.61	42.35	38.61	(1,056.63)	85.34
<b>Other Information</b>								
Assets	17,951.60	11,339.72	2,252.70	205.48	1,922.15	-	25,226.88	58,898.54
Liabilities	32,536.50	900.00	-	-	-	-	25,462.04	58,898.54
Capital expenditure	726.77	173.21	79.70					979.68

**SEGMENT INFORMATION FOR THE YEAR ENDED MARCH 31, 2015 AS PER IND AS – 108**
*(₹ in lakhs)*

Particulars	Sugar	Co-generation	Distillery	IML	IML Yalahanka	Others	Unallocated	Total
<b>Total Sales</b>	23,984.80	8,630.88	3,523.27	8,732.71	233.23	2.87	-	45,107.75
External Sales	19,158.81	3,618.93	2,761.82	8,732.71	233.23	2.87	-	34,508.36
Inter- segment Sales	4,825.99	5,011.95	761.45	-	-	-	-	10,599.39
Segment Result	(1,788.62)	3,830.48	(262.47)	634.43	60.59	2.87	687.42	3,164.69
Unallocated Corporate Expenditure	-	-	-	-	-	-	557.15	557.15
Interest expenses	-	-	-	-	-	-	2,535.95	2,535.95
Interest Income	-	-	-	-	-	-	926.97	926.97
Profit Before Depreciation & Exceptional Items & Tax	(1,788.62)	3,830.48	(262.47)	634.43	60.59	2.87	(1,478.71)	998.56
Depreciation	530.83	366.37	105.36	8.77	-	-	-	1,011.33
Profit Before Exceptional Items & Tax	(2,319.45)	3,464.11	(367.83)	625.66	60.59	2.87	(1,478.71)	(12.77)
Exceptional Items	-	-	-	-	-	-	-	-

Profit Before Tax	(2,319.45)	3,464.11	(367.83)	625.66	60.59	2.87	(1,478.71)	(12.77)
Tax Expenses							(44.92)	(44.92)
Net profit	(2,319.45)	3,464.11	(367.83)	625.66	60.59	2.87	(1,523.63)	(57.69)
<b>Other Information</b>								
Assets	17,245.68	11,166.51	2,206.07	205.48	-		29,677.45	60,501.20
Liabilities	32,507.76	2,000.00	-		10.12		25,983.32	60,501.20
Capital expenditure	5,262.39	14.09	2,085.53					7,362.01

**RESULTS OF OUR OPERATIONS**

(₹ in lakhs)

Particulars	For the Financial Year ended,						
	2019	% of Total Income	2018	% of Total Income	2017 (Proforma)	% of Total Income	2016 (Proforma)
<b>REVENUE:</b>							
Revenue from Operations	30,679.58	99.65%	25,928.30	96.41%	32,184.21	99.68%	40,575.83
Other Income	107.97	0.35%	964.80	3.59%	103.91	0.32%	288.73
<b>Total revenue</b>	<b>30,787.55</b>	<b>100.00%</b>	<b>26,893.11</b>	<b>100.00%</b>	<b>32,288.12</b>	<b>100.00%</b>	<b>40,864.56</b>
<b>EXPENSES:</b>							
Cost of materials consumed	27,665.37	89.86%	22,695.78	84.39%	12,819.41	39.70%	22,928.76
Changes in inventories	(6,280.27)	-20.40%	(7,894.47)	-29.35%	6,292.78	19.49%	2,535.09
Other Manufacturing Expenses	2,058.96	6.69%	2,425.34	9.02%	2,375.51	7.36%	2,455.17
Excise Duty	2,044.29	6.64%	3,746.95	13.93%	3,782.47	11.71%	7,011.17
Employee benefits expense	1,303.28	4.23%	1,242.97	4.62%	1,361.77	4.22%	1,215.76
Finance cost	3,635.69	11.81%	2,085.05	7.75%	2,491.41	7.72%	1,787.34
Depreciation and amortization expense	1,334.28	4.33%	1,319.96	4.91%	1,153.47	3.57%	1,133.96
Other expenses	1,414.66	4.59%	1,357.72	5.05%	965.95	2.99%	1,069.57
<b>Total expenses</b>	<b>33,176.27</b>	<b>107.76%</b>	<b>26,979.30</b>	<b>100.32%</b>	<b>31,242.78</b>	<b>96.76%</b>	<b>40,136.83</b>
<b>Net Profit / (Loss) before Tax</b>	<b>(2,388.72)</b>	<b>-7.76%</b>	<b>(86.20)</b>	<b>-0.32%</b>	<b>1,045.34</b>	<b>3.24%</b>	<b>727.73</b>
<b>Less: Provision for Tax</b>							
Current tax	0	0.00%	6.08	0.02%	223.16	0.69%	155.45
Deferred tax	(626.72)	-2.04%	334.39	1.24%	215.93	0.67%	486.93
<b>Total</b>	<b>(626.72)</b>	<b>-2.04%</b>	<b>340.47</b>	<b>1.27%</b>	<b>439.09</b>	<b>1.36%</b>	<b>642.38</b>
<b>Net Profit / ( Loss ) for the period after tax but before extra ordinary items</b>	<b>(1,761.99)</b>	<b>-5.72%</b>	<b>(426.67)</b>	<b>-1.59%</b>	<b>606.25</b>	<b>1.88%</b>	<b>85.35</b>
Extraordinary Items							
<b>Net Profit / ( Loss ) for the period after tax and after extra ordinary items available for appropriation</b>	<b>(1,761.99)</b>	<b>-5.72%</b>	<b>(426.67)</b>	<b>-1.59%</b>	<b>606.25</b>	<b>1.88%</b>	<b>85.35</b>



## **Fiscal 2019 compared with Fiscal 2018**

### *Revenue from Operation*

Revenue from operations had increased by 18.32%, from ₹ 25,928.30 lakhs in Fiscal 2018 to ₹ 30,679.58 lakhs in Fiscal 2019. The increase is mainly attributable to good cane harvesting leading to better sugarcane crushing and also due to a marginal increase in sugar prices.

### *Other Income*

Other income had decreased by 88.81%, from ₹ 964.80 lakhs in Fiscal 2018 to ₹ 107.97 lakhs in Fiscal 2019 on account of decrease of non-recurring miscellaneous income.

### *Cost of Material Consumed*

Cost of material consumed had increased by 21.90%, from ₹ 22,695.78 lakhs in Fiscal 2018 to ₹ 27,665.37 lakhs in Fiscal 2019. This increase is due to increase in Minimum Support price and increase in cultivation of sugarcane, resulting in increase in cost of material consumed.

### *Changes in inventories*

Changes in Inventories had a variance by 20.45% from ₹ (7,894.47) lakhs in Fiscal 2018 to ₹ (6,280.27) lakhs in Fiscal 2019.

### *Other Manufacturing Expenses*

Other Manufacturing Expenses have decreased by 15.11% from ₹ 2,425.34 lakhs in Fiscal 2018 to ₹ 2,058.96 lakhs in the Fiscal 2019 primarily on account of reduction of processing & transportation charges and also due to lower power & fuel cost, as our Company used higher captive power.

### *Excise Duty*

Excise Duty had decreased by 45.44%, from ₹ 3,746.95 lakhs in Fiscal 2018 to ₹ 2,044.29 lakhs in Fiscal 2019 primarily on account of abolishment of Excise Duty from July 01, 2017 onwards (except on IML sales).

### *Employee Benefit Expenses*

Employee benefit expenses had increased by 4.85%, from ₹ 1,242.97 lakhs in Fiscal 2018 to ₹ 1,303.28 lakhs in Fiscal 2019 primarily on account of annual increments and incentives.

### *Finance Cost*

Finance Cost had increased by 74.37% from ₹ 2,085.05 lakhs in Fiscal 2018 to ₹ 3,635.69 lakhs in Fiscal 2019. This is primarily on account of increased interest liability on account of new loans taken during last financial year and end of their moratorium period, if any.

### *Depreciation and Amortization Expenses*

Depreciation had increased by 1.08%, from ₹ 1,319.96 lakhs in Fiscal 2018 to ₹ 1,334.28 lakhs in Fiscal 2019 on account of marginal increase in gross block of Assets by during the year.

### *Other Expenses*

Other expenses had increased by 4.19% from ₹ 1,357.72 lakhs in Fiscal 2018 to ₹ 1,414.66 lakhs in Fiscal 2019. The increase is to be attributed to an increase in various expenses including loss on sale of assets, advertisement, publicity and sale promotion expenses and insurance charges.

### *Tax Expenses*

The Company's tax expenses had decreased by 284.08% from ₹ 340.47 lakhs in the Fiscal 2018 to a negative ₹ 626.72 lakhs in Fiscal 2019. This was mainly due to nil tax provisions as the Company reported a loss in the Fiscal 2019 and also due to higher Deferred Tax write-off.

### *Profit after Tax*

After accounting for taxes at applicable rates, our Company reported a loss of ₹ 1,761.99 lakhs in Fiscal 2019 as compared to a loss of ₹ 426.67 lakhs in Fiscal 2018, mainly due to increase in cost of materials consumed and other reasons as stated above.

## **Fiscal 2018 compared with Fiscal 2017**

### *Revenue from Operation*

Revenue from operations had decreased by 19.44%, from ₹ 32,184.21 lakhs in Fiscal 2017 to ₹ 25,928.30 lakhs in Fiscal 2018. Our Company is a seasonal enterprise and the Fiscal 2018 witnessed average rainfall resulting in good cane harvesting. However due to higher sugar surplus the overall prices of sugar had reduced in Karnataka i.e. reduced per quintal sugar price the overall revenue has decreased.

### *Other Income*

Other income had increased by 828.45%, from ₹ 103.91 lakhs in Fiscal 2017 to ₹ 964.80 lakhs in Fiscal 2018 on account of increase in miscellaneous income.

### *Cost of Material Consumed*

Cost of material consumed had increased by 77.04%, from ₹ 12,819.41 lakhs in Fiscal 2017 to ₹ 22,695.78 lakhs in Fiscal 2018. This increase is due to increase in Minimum Support price and increase in cultivation of sugarcane, resulting in increase in cost of material consumed.

### *Changes in inventories*

Changes in Inventories had a variance by 225.45% from ₹ 6,292.78 lakhs in Fiscal 2017 to ₹ (7,894.47) lakhs in Fiscal 2018.

### *Other Manufacturing Expenses*

Other Manufacturing Expenses have increased by 2.10% from ₹ 2,375.51 lakhs in Fiscal 2017 to ₹ 2,425.34 lakhs in the Fiscal 2018 primarily on account of reduction of repairs and maintenance expenses.

### *Excise Duty*

Excise Duty had decreased by 0.94%, from ₹ 3,782.47 lakhs in Fiscal 2017 to ₹ 3,746.95 lakhs in Fiscal 2018 primarily on account of reduction in Sales during the year.

### *Employee Benefit Expenses*

Employee benefit expenses had decreased by 8.72%, from ₹ 1,361.77 lakhs in Fiscal 2017 to ₹ 1,242.97 lakhs in Fiscal 2018 primarily on account of reduction in number of employees.

### *Finance Cost*

Finance Cost had decreased by 16.31% from ₹ 2,491.41 lakhs in Fiscal 2017 to ₹ 2,085.05 lakhs in Fiscal 2018. This is primarily on account of decrease in interest paid on loans taken, moratorium period available on new term loans and marginal increase in borrowing costs.

### *Depreciation and Amortization Expenses*

Depreciation had increased by 14.43%, from ₹ 1,153.47 lakhs in Fiscal 2017 to ₹ 1,319.96 lakhs in Fiscal 2018 on account of increase in gross block by during the year.

### *Other Expenses*

Other expenses had increased by 40.56% from ₹ 965.95 lakhs in Fiscal 2017 to ₹ 1,357.72 lakhs in Fiscal 2018. The increase is to be attributed to an increase in advertisement, publicity and sale promotion and an increase in legal, professional and consultancy charges.

### *Tax Expenses*

The Company's tax expenses had decreased by 22.46% from ₹ 439.09 lakhs in the Fiscal 2017 to ₹ 340.47 lakhs in Fiscal 2018. This was mainly due to decrease in tax provisions as the Company reported a loss in the Fiscal 2018.

### *Profit after Tax*

After accounting for taxes at applicable rates, our Company reported a loss of ₹ 426.67 lakhs in Fiscal 2018 as compared to a profit of ₹ 606.25 lakhs in Fiscal 2017 as a result of reasons stated above.

## **Fiscal 2017 compared with Fiscal 2016**

### *Revenue from Operation*

Revenue from operations had decreased by 19.44%, from ₹ 40,575.83 lakhs in Fiscal 2016 to ₹ 32,184.21 lakhs in Fiscal 2017. Our Company is a seasonal enterprise and the Fiscal 2017 witnessed lower than average rainfall resulting in reduced overall sugarcane produce. Because of this the production of most of our segments (sugar, co-generation, IML, distillery) decreased and our Company recorded lower revenue from operations.

### *Other Income*

Other income had decreased by 64.01%, from ₹ 288.73 lakhs in Fiscal 2016 to ₹ 103.91 lakhs in Fiscal 2017 on account of decrease in other non-operating income.

### *Cost of Material Consumed*

Cost of material consumed had decreased by 44.09%, from ₹ 22,928.76 lakhs in Fiscal 2016 to ₹ 12,819.41 lakhs in Fiscal 2017. This reduction is due to below average rainfall in the region during the Fiscal 2017 and consequent lower sugarcane harvest, resulting in decrease in cost of material consumed. The quantity of cane crushed during the FY 2015-16 was 8,00,234 Tons, whereas the same for FY 2016-17 was only 3,10,681 Tons, mainly due to draught leading to shortage of cane availability. Hence Cost of Material consumed for FY 2016-17 showed a substantial decrease from that of previous year.

### *Changes in inventories*

Changes in Inventories had a variance by 148.23% from ₹ 2,535.09 lakhs in Fiscal 2016 to ₹ 6,292.78 lakhs in Fiscal 2017.

### *Other Manufacturing Expenses*

Other Manufacturing Expenses have decreased by 3.24% from ₹ 2,455.17 lakhs in Fiscal 2016 to ₹ 2,375.51 lakhs in the Fiscal 2017 primarily on account of lower scale of operations due to lower sugarcane production.

### *Excise Duty*

Excise Duty had decreased by 46.05%, from ₹ 7,011.17 lakhs in Fiscal 2016 to ₹ 3,782.47 lakhs in Fiscal 2017 primarily on lower sales of sugar and also other allied products during the year.

### *Employee Benefit Expenses*

Employee benefit expenses had been increased by 12.01%, from ₹ 1,215.76 lakhs in Fiscal 2016 to ₹ 1,361.77 lakhs in Fiscal 2017 primarily on account of annual increments and increase in directors' remuneration<sup>(1)</sup>.

<sup>(1)</sup> Our Company had substantially increased its operations during the financial year 2016-17, mainly due to its increase of sugar crushing capacity from 5,500 TCD to 8,500 TCD and also had recently started the new segment of Vinegar manufacturing, which required additional responsibility and time from the executive Directors of the Company. Also, the Company is in the process of planning for setting up of 2nd integrated unit for manufacture for sugar and allied products which requires the planning expertise and continued presence. Considering the above enhanced responsibility, the Board, after following due process of law, has approved the increase in Director's Remuneration.

### *Finance Cost*

Finance Cost had increased by 39.39% from ₹ 1,787.34 lakhs in Fiscal 2016 to ₹ 2,491.41 lakhs in Fiscal 2017. This is primarily on account of increase in borrowing cost, increase in interest rates and interest paid on loans taken and paid off during the reporting period.

### *Depreciation and Amortization Expenses*

Depreciation had increased by 1.72%, from ₹ 1,133.96 lakhs in Fiscal 2016 to ₹ 1,153.47 lakhs in Fiscal 2017 on account of increase in gross block by ₹ 785.34 lakhs.

### *Other Expenses*

Other expenses had decreased by 9.69% from ₹ 1,069.57 lakhs in Fiscal 2016 to ₹ 965.95 lakhs in Fiscal 2017. The decrease is to be attributed to decrease in license fees and taxes attributable to sugarcane purchase and reduction of other miscellaneous expenses.

### *Tax Expenses*

The Company's tax expenses had decreased by 31.65% from ₹ 642.38 lakhs in the Fiscal 2016 to ₹ 439.09 lakhs in Fiscal 2017. This is primarily due to an decrease in deferred tax which comprises the total tax expenses. The decrease in deferred tax liability is primarily due to decrease in timing difference as per the Ind AS calculations of deferred tax done for the purpose of Proforma financials in the Restated Financial Statements.

### *Profit after Tax*

After accounting for taxes at applicable rates, our profit after tax had increased by 610.31%, from ₹ 85.35 lakhs in Fiscal 2016 to ₹ 606.25 lakhs in Fiscal 2017 as a result of reasons stated above.

### **Other Material Analysis of the Financial Statements**

The reason for the substantial increase / decrease in the above financial heads is explained as below:

#### **a) Long Term Borrowings from March 31, 2018 to March 31, 2019;**

The increase in Long Term Borrowings from March 31, 2018 to March 31, 2019 pertains to Term Loan sanctioned and received from The Belgaum District Central Cooperative Bank Ltd. (BDCC Bank) amounting to ₹ 3,000 lakhs and ₹ 2,500 lakhs. These loans are being utilised for the purpose of expansion of the existing distillery unit from 35 KLPD to 100 KLPD.

#### **b) Short Term Loans and Advances from March 31, 2018 to March 31, 2019;**

Majority of the amounts of the 'Short Term Loans & Advances' have been classified as 'Other Current Assets' under the Ind AS presentation in the Red Herring Prospectus. The Other Current Assets mainly include Deposits with Statutory Authorities, Cane Purchase Advance and advances to Harvesting and Transport Contractors (H & T Contractors) for harvesting cane from field and transporting it to the factory. As an Industry practice, these contractors are paid a substantial amount as an advance i.e. before the beginning of the Crushing Season (September / October to

March / April each year). During the Crushing Season, these contractors provide the required service ensuring smooth availability and transport of sugarcane to our factory. According to the duration of service rendered and other factors, the final accounts are settled after the end of the Crushing Season every year and hence as at March 31 of each year, majority of the advance is charged to the P&L A/c.

However, for the financial year ended March 31, 2019, the outstanding advances represent amounts that have been paid and no service against the same has been received or the account against the service is not yet settled. Thus the said amount is kept under Other Current Assets and there is a substantial increase in the same for the financial year ended March 31, 2019 as compared to year ended March 31, 2018.

## Financial Condition

### Assets

The following table sets forth the principal components of our assets as of the dates specified:

(₹ in lakhs)

Particulars	As at March 31,			
	2019	2018	2017	2016
<b>ASSETS</b>				
<b>A) Non - Current Assets</b>				
a) Fixed Assets				
i.) Property, Plant and Equipments	26,440.54	27,188.80	24,069.44	24,413.23
ii.) Intangible Assets	-	-	-	-
iii.) Capital Work in Progress	1,126.02	-	3,834.55	128.82
b) Non Current Investment	108.24	53.24	37.98	37.65
c) Other Non Current Financial Assets	214.60	213.45	262.89	263.18
	<b>27,889.40</b>	<b>27,455.49</b>	<b>28,204.86</b>	<b>24,842.88</b>
<b>B) Current Assets</b>				
a) Inventories	32,434.62	26,157.20	18,199.84	24,446.57
b) Trade Receivables	3,835.87	3,388.06	4,435.39	1,857.18
c) Cash and Cash Equivalents	184.35	745.72	1,273.65	5,164.93
d) Current Financial Assets	4.47	4.61	15.52	44.64
e) Other Current Assets	7,606.26	4,667.56	2,190.73	2,542.33
	<b>44,065.56</b>	<b>34,963.14</b>	<b>26,115.13</b>	<b>34,055.65</b>
<b>TOTAL (A+B)</b>	<b>71,954.96</b>	<b>62,418.63</b>	<b>54,319.99</b>	<b>58,898.53</b>

### Discussion on select Balance Sheet items:

#### Fixed Assets:

During the Fiscal 2017, the total Property, Plant and Equipments decreased by ₹ 343.79 lakhs comprising of certain additions to the Sugar and Distillery segment and also due to the increase in depreciation during the year.

During the Fiscal 2018, Company added new Assets mainly comprising of plant and machinery of ₹ 4,085.36 lakhs and also addition in factory and other buildings of ₹ 346.09 lakhs.

During the Fiscal 2019, the total Property, Plant and Equipments decreased by ₹ 748.26 lakhs mainly due to the written down value effect during the year.

#### Capital Work in Progress

During the Fiscal Year 2017, the closing capital work in progress stood at ₹ 3,834.55 lakhs constituting majorly of purchase of plant and machinery including a steam optimizer for increase in sugar manufacturing operations, construction of IML godown and purchase of IML packing machinery.

There was no capital work in progress during the Fiscal 2018

During the Fiscal Year 2019, the closing capital work in progress stood at ₹ 1,126.02 lakhs constituting construction work undertaken by the Company for increase in the distillery capacity from 35 KLPD to 100 KLPD.

## Inventories:

Our Company is a seasonal enterprise being heavily dependent on the availability of sugarcane on a timely basis. Our inventory of raw materials comprises of coal, molasses and bagasse which are used for co-generation and Distillery segments. Our finished stock of inventories comprises of Sugar, Rectified Spirit, MG Spirit, Neutral Spirit, IML, Compost, Denature spirit and Vinegar among others.

During Fiscal 2017, 2018 and 2019, the inventory levels of our company has been stood at ₹ 18,199.84lakhs, ₹ 26,157.20lakhs ₹ 32,434.62lakhs respectively.

## Liquidity and Capital Resources

Historically, our primary liquidity requirements have been to finance our working capital needs, loan repayments, and our capital expenditures. To fund these requirements we have relied on short-term and long-term borrowings and cash flows from operations. Our business requires a significant amount of working capital. We expect to meet our working capital requirements for Fiscal 2020 primarily from bank finance and also from the funds from this Fresh issue, as may be required.

## Cash Flows

The table below sets forth our net cash flows with respect to operating activities, investing activities and financing activities for the periods indicated

(₹ in lakhs)

Particulars	Year ended March 31,			
	2019	2018	2017	2016
Net Cash from Operating Activities	2,506.27	(5,459.67)	6,169.97	3,000.65
Net Cash from Investing Activities	(1,847.34)	(621.67)	(4,516.22)	(577.33)
Net Cash used in Financing Activities	(1,220.30)	5,553.43	(5,545.03)	749.19

### Cash Flows from Operating Activities

Net cash flow from operating activities for the Fiscal 2019 was ₹ 2,506.27 lakhs. This was primarily due to changes in depreciation, interest and finance charges, trade receivables, trade payables and inventories. The net cash from operating activities prior to working capital adjustment was due to addition of ₹ 3,635.69 lakhs of finance cost and ₹ 1,334.28 lakhs of depreciation. Balance changes were due to working capital adjustments.

Net cash flow from operating activities for the Fiscal 2018 was ₹ (5,459.67) lakhs. This was primarily due to changes in depreciation, interest and finance charges, trade receivables and inventories. The net cash from operating activities prior to working capital adjustment was due to addition of ₹ 2,085.05 lakhs of finance cost and ₹ 1,319.96 lakhs of depreciation. Balance changes were due to working capital adjustments.

Net cash flow from operating activities for the Fiscal 2017 was ₹ 5,256.36 lakhs. This was primarily due to changes in depreciation, interest and finance charges, trade receivables and inventories. The net cash from operating activities prior to working capital adjustment was due to addition of ₹ 2,484.32 lakhs of finance cost and ₹ 1,129.13 lakhs of depreciation. Balance changes were due to working capital adjustments.

### Cash Flows from Investment Activities

In the Fiscal 2019, the net cash used for Investing Activities was ₹ 1,847.34 lakhs. A major part of the net cash used comprises of purchase of fixed assets (net) (including changes in Capital work in progress) of ₹ 1,795.76 lakhs and investment in BDCC shares of ₹ 55.00 lakhs.

In the Fiscal 2018, the net cash used for Investing Activities was ₹ 621.67 lakhs. A major part of the net cash used comprises of purchase of fixed assets (net) of ₹ 609.81 lakhs and investment in BDCC shares of ₹ 15.26 lakhs.

In the Fiscal 2017, the net cash used for Investing Activities was ₹ 4,516.22 lakhs. A major part of the net cash used comprises of purchase of fixed assets (net) (including changes in Capital work in progress) of ₹ 4,520.19 lakhs.

### **Cash Flows from Financing Activities**

Net cash outflow from financing activities in fiscal 2019 was ₹ 1,220.30 lakhs. This was on account of repayment of short term borrowings, increase in long term borrowings and payment of interest.

Net cash inflow from financing activities in fiscal 2018 was ₹ 5,553.43 lakhs. This was on account of increase in short term and long term borrowings and payment of interest.

Net cash outflow from financing activities in fiscal 2017 was ₹ 5,545.03 lakhs. This was on account of repayment in short term and long term borrowings and payment of interest and payment of dividend & related taxes.

### **Off-Balance Sheet Arrangements**

We do not have any material off-balance sheet arrangements.

### **Indebtedness**

The following table sets forth our secured and unsecured debt position as at March 31, 2019.

(₹ in lakhs)

<b>Particulars</b>	<b>Amount</b>	<b>Amount</b>
<b>Secured</b>		33,879.42
Fund based borrowings (including current maturities of long term liabilities)	33,879.42	
Non fund based borrowings	Nil	
<b>Unsecured</b>		Nil
<b>Total</b>	<b>33,879.42</b>	<b>33,879.42</b>

For more information regarding our indebtedness, please refer to the sections titled “*Financial Indebtedness*” and “*Financial Statements*” on page nos. 273 and 202, respectively, of this Red Herring Prospectus.

### **Contingent Liabilities and Commitments**

Set forth below are details on our contingent liabilities and commitments as at March 31, 2019:

(₹ in lakhs)

<b>Particulars</b>	<b>As at March 31, 2019</b>
Outstanding guarantees and counter guarantees to various Banks	57.00
Court Cases	1,506.15
Non fulfillment of export obligation under Zero Duty EPCG Scheme	289.99
<b>Total</b>	<b>1,853.14</b>

### **Related Party Transactions**

We have engaged in the past, and may engage in the future, in transactions with related parties, including with promoters and certain key management members on an arm’s lengths basis. Such transactions could be for remuneration, rent paid and loan availed.

Further, the related party transactions include purchases made from Promoters / Directors which indicates the purchase of sugarcane from the agricultural fields owned by such Promoters / Directors in their respective individual capacities. For details of our related party transactions, please refer to the sub- section titled “*Restated Financial Statements – Annexure VI – Note 34 – Restated Statement of Related Party Transactions*” on page no. 238 of this Red Herring Prospectus.

### **Qualitative Disclosure about Risks and Risk Management**

#### **Raw material cost risk**

Our operations are exposed to fluctuations in the market price of our basic raw materials viz. sugarcane and coal. Sugarcane is a highly regulated agro-product with the government setting the FRP (Fair and Remunerative Price). This means our company has to purchase sugarcane from the farmers at the price decided by the Government. The market price of coal is dependent on demand and supply, its availability from suppliers, cost of transportation etc. Any significant upward fluctuations may result in an increase in price at which we source these raw materials.



### ***Inflation Risk***

Inflationary factors such as increases in the input costs and overhead costs may adversely affect our operating results. There may be time lag in recovering the inflation impact from our customer and we may not be able to recover the full impact of such inflation. A high rate of inflation in the future may, therefore, have an adverse effect on our ability to maintain our profit margins.

### ***Interest Rate Risk***

As of March 31, 2019, a part of the indebtedness incurred by us carried interest at floating rates with the provision for periodic reset of interest rates and thus, we are exposed to market risk as a result of changes in interest rates. Upward fluctuations in interest rates increase the cost of both existing and new debts. It is likely that in the current Fiscal and in future periods, our borrowings and interest expenses may rise substantially, given our growth plans.

### ***Credit Risk***

We are exposed to credit risk on monies owed to us by our customers and these trade receivables are typically unsecured. If our customers do not pay us promptly, or at all, we may have to make provisions for, or write off, such amounts. As at March 31, 2019, our trade receivables were ₹ 3,835.87 lakhs.

### ***Liquidity risk***

The principal sources of liquidity are cash and cash equivalents and the cash flow that is generated from operations. We borrow short term and long term loans from banks and financial institutions to meet our working capital requirements. As of March 31, 2019 we have outstanding borrowings of ₹ 33,879.42 lakhs from banks (including current maturities of long term debts). We largely depend on the banks for working capital financing. We may be exposed to liquidity risk if we do not generate enough cash flow from operations, and do not repay the loans from the banks or pay off our trade payables as per the agreed contractual terms.

### ***Foreign currency exchange risk***

We may incur capital expenditure including cost of procuring equipment and machinery, in currencies other than in the Indian Rupee. We may also make sales of IML and purchase of raw materials, in currencies other than in the Indian Rupee. Any significant decline in the value of the Indian Rupee against foreign currencies may lead to an increase in our costs and expenditures.

### ***Unusual or Infrequent Events or Transactions***

Except as described in “*Risk Factors*” and “*Our Business*”, on page no. 17 and 130, respectively, of this Red Herring Prospectus there have been no events or transactions to our knowledge which may be described as “unusual” or “infrequent”.

### ***Significant Economic Changes that Materially affect or are likely to affect Income from Continuing Operations***

Except as described in “*Risk Factors*” and “*Key Regulations and Policies*” on page nos. 17 and 156, respectively, of this Red Herring Prospectus, to the best of our knowledge, there have been no significant economic or regulatory changes that we expect could have a material adverse effect on our results of operations.

### ***Known trends and uncertainties***

Our business has been impacted and we expect will continue to be impacted by the trends identified above in “*Management's Discussion and Analysis of Financial Condition and Results of Operations– Significant Factors Affecting Our Results of Operations and Financial Condition*” and the uncertainties described in “*Risk Factors*” on page nos. 252 and 17, respectively of this Red Herring Prospectus. To our knowledge, except as we have described in this Red Herring Prospectus, there are no known factors that we expect to have a material adverse impact on our revenues or income from operations.

### ***Future relationship between costs and income***

Other than as described in this section and in “*Risk Factors*” and “*Our Business*” on page nos. 17 and 130, respectively of this Red Herring Prospectus to the best of our knowledge, there are no factors that are expected to have a material adverse effect on the relationship between our costs and income.

### ***Total turnover in each major industry segment***

Other than as described in the Restated Financial Statements and this Management's Discussion and Analysis of Financial Condition and Results of Operations, we do not report any other segments for our financial statements prepared in accordance with Ind As.

### ***Publicly Announced New Products or Business Segments / Material increases in Revenue due to Increased Disbursements and Introduction of New Products***

We have not publicly announced any new products or business segments nor have there been any material increases in our revenues due to increased disbursements and introduction of new products.

### ***Seasonality of business***

Our business is seasonal in nature. For further details, see the discussions regarding the seasonality of our business in “*Risk Factors*” and “*Our Business*” on page nos. 17 and 130, respectively, of this Red Herring Prospectus.

### ***Dependence on a few Customers and Suppliers***

The revenue from our top 10 Customers constituted approximately 41.26% of the total revenue for the financial year ended March 31, 2019.

### ***Competitive Conditions***

We operate in a competitive environment. For further details, see the discussions regarding our competition in “*Risk Factors*” and “*Our Business*” on page nos. 17 and 130, respectively, of this Red Herring Prospectus.

### ***Recent Accounting Pronouncements***

#### ***Ind AS 116 Leases:***

Ind AS 116, Leases: The Ministry of Corporate Affairs has notified the Ind AS 116, Leases which will be effective from April 1, 2019. Ind AS 116 would replace the existing leases standard Ind AS 17. The standard sets out the principles for the recognition, measurement, presentation and disclosures for both parties to a contract, i.e. the lessee and the lessor. Ind AS 116 introduces a single lessee accounting model and requires a lessee to recognise assets and liabilities for all leases with a term of more than 12 months, unless the underlying asset is of low value. Currently, operating lease expenses are charged to the statement of profit and loss. The Company is currently evaluating the effect of Ind AS 116 on the financial statements.

#### ***Ind AS 12 Income Taxes:***

On March 30, 2019, the Ministry of Corporate Affairs has notified limited amendments to Ind AS 12 ‘Income Taxes’. The amendments require an entity to recognise the income tax consequences of dividends as defined in Ind AS 109 when it recognises a liability to pay a dividend. The income tax consequences of dividends are linked more directly to past transactions or events that generated distributable profits than to distributions to owners. Therefore, an entity shall recognize the income tax consequences of dividends in profit or loss, other comprehensive income or equity according to where the entity originally recognised those past transactions or events. The amendment will come into force for accounting periods beginning on or after April 1, 2019. The Company is evaluating the effect of the above in the financial statements.

#### ***Ind AS 12, Uncertainty over Income Tax Treatments:***

On March 30, 2019, Ministry of Corporate Affairs (“MCA”) has notified the Companies (Indian Accounting Standards) Amendment Rules, 2019 containing Appendix C to Ind AS 12, Uncertainty over Income Tax Treatments which clarifies the application and measurement requirements in Ind AS 12 when there is uncertainty over income tax treatments. The current and deferred tax asset or liability shall be recognized and measured by applying the requirements in Ind AS 12 based on the taxable profit (tax loss), tax bases, unused tax losses, unused tax credits and tax

---

rates determined by applying this appendix. The amendment is effective for annual periods beginning on or after April 1, 2019. The Company is evaluating the effect of the above in the financial statements.

*Ind AS 19 'Employee Benefits':*

On March 30, 2019, the Ministry of Corporate Affairs has notified limited amendments to Ind AS 19 'Employee Benefits' in connection with accounting for plan amendments, curtailments and settlements. The amendments require an entity to use updated assumptions to determine current service cost and net interest for the remainder of the period after a plan amendment, curtailment or settlement and to recognise in profit or loss as part of past service cost, or a gain or loss on settlement, any reduction in a surplus, even if that surplus was not previously recognised because of the impact of the asset ceiling. The amendment will come into force for accounting periods beginning on or after April 1, 2019. The Company is evaluating the effect of the above in the financial statements.

***Auditor qualification***

There are no reservations, qualifications or adverse remarks in the audit report submitted by our auditors in the last five financial years.

## FINANCIAL INDEBTEDNESS

Set forth below, is a brief summary of our Company's borrowings as on March 31, 2019 together with a brief description of certain significant terms of such financing arrangements.

Nature of Borrowing	Amount (₹ in Lakhs)
Secured Borrowings	33,879.42
Unsecured Borrowings	-
<b>Total<sup>(1)</sup></b>	<b>33,879.42</b>

<sup>(1)</sup>Includes ₹ 1,945.84 lakhs shown under Current Liabilities as 'Current Maturities of Long Term Debt'.

### Details of Secured Loans

(₹ in lakhs)

Name of Lender	Type of Loan	Date of Sanction	Amount Sanctioned	Amount Outstanding as on March 31, 2019	Interest (in % p.a.)	Repayment Schedule	Security
The Belgaum District Central Cooperative Bank Ltd.	SEFASU Term Loan	June 25, 2014	1,291.00	179.16	13.00%	Repayable in 36 monthly installments of ₹ 35.83 lakhs each commencing from August 2016.	<b>Collateral Security</b> - Pari passu charge on sugar plant <b>Guarantors</b> - Umesh V Katti, Nikhil U Katti, Mallikarjun Pujar, Ramesh V Katti, Sandeep Katti
The Belgaum District Central Cooperative Bank Ltd.	Term Loan	June 01, 2017	4,000.00	3,499.99	13.00%	Repayable after a moratorium period of one year in 24 equal quarterly installments of ₹ 166.66 lakhs.	<b>Primary Security</b> - Charge over all moveable and immoveable assets of the sugar factory <b>Personal Guarantee</b> - Joint and Several Irrevocable Personal guarantee by Board of Directors.
The Belgaum District Central Cooperative Bank Ltd.	Term Loan (Hypothecation)	May 29, 2018	3,000.00	2,550.00	13.00%	Repayable in 20 equal quarterly installments of ₹ 150.00 lakhs.	<b>Primary Security</b> - Charge on all movable and immovable Assets of the Co-Gen Plant. <b>Personal Guarantee</b> - Joint and Several Irrevocable Personal guarantee by Board of Directors.
The Belgaum District Central Cooperative Bank Ltd.	Term Loan (Hypothecation)	September 05, 2018	2,500.00	2,250.00	13.00%	Repayable in 20 equal quarterly installments of ₹ 125.00 lakhs.	<b>Primary Security</b> - Charge on all movable and immovable Assets of the Co-Gen Plant and Machinery <b>Personal Guarantee</b> - Joint and Several Irrevocable Personal guarantee by Board of Directors.

Name of Lender	Type of Loan	Date of Sanction	Amount Sanctioned	Amount Outstanding as on March 31, 2019	Interest (in % p.a.)	Repayment Schedule	Security
The Belgaum District Central Cooperative Bank Ltd.	Term Loan	September 05, 2018	2,250.00	0.00 <sup>(1)</sup>	13.00%	Repayable after a moratorium period of two year in 24 equal quarterly installments of ₹ 112.50 lakhs.	<b>Primary Security</b> – First Charge on distillery plant. <b>Collateral Security</b> – Charge on net block of sugar and current assets of o-generation plant favouring the bank. <b>Guarantors</b> - Joint and Several Irrevocable Personal guarantee by Board of Directors
Bank of India, Shahapur Branch Belgaum	CC – Pledge	November 30, 2018	10,000.00	9,192.91	BR 8.50% + BSS 0.30% + FR 3.35% = 12.15%	Repayable on demand	<b>Primary Security</b> - Pledge of stock of Sugar <b>Collateral Security</b> - First Pari Passu charge on fixed assets of Sugar, Cogeneration and Distillery units along with BDCC Bank. <b>Guarantors</b> - Umesh Katti, Nikhil Katti, Ramesh Katti and Mallikarjun Pujar
Bank of India, Shahapur Branch Belgaum	CC - Hypothecation	November 30, 2018	1,500.00	1,483.33	BR 8.50% + BSS 0.30% + FR 3.35% = 12.15%	Repayable on demand	<b>Primary Security</b> - Hypothecation of stocks and Book debts of Co-gen plant and distillery unit <b>Collateral Security</b> - First Pari Passu charge on fixed assets of Sugar, Cogeneration and Distillery units along with BDCC Bank. <b>Guarantors</b> - Umesh Katti, Nikhil Katti, Ramesh Katti and Mallikarjun Pujar
State Bank of India, SME Branch Belgaum	WHR CC	December 12, 2018	6,000.00	6,001.44 <sup>(2)</sup>	BR 8.50 + FR 1.50 = 10.00%	Repayable on demand	<b>Primary Security</b> - Pledge of free sugar in warehouses collaterally managed by bank appointed Collateral Manager and pari-passu first charge by way of hypothecation on raw sugar, SIP and other current assets of the company. <b>Collateral Security</b> - Second charge on Factory Land and building at survey No. 136-152, situated at Bellad Bagewadi, Hukkeri Taluka, Belgavi, Karnataka

Name of Lender	Type of Loan	Date of Sanction	Amount Sanctioned	Amount Outstanding as on March 31, 2019	Interest (in % p.a.)	Repayment Schedule	Security
							measuring 132 Acres and 34 Guntas in the name of M/s Vishwaraj Sugar Industries Ltd. <b>Guarantors</b> - Umesh Katti and Nikhil Katti
Bank of India	Harvesting & Transportation loan	May 19, 2018	5,000.00	5,000.00	BR - 8.50% BSS - 0.30% FR - 2.20% = 11.00%	To be liquidated in 12 months from the date of disbursement.	<b>Corporate Guarantee</b> of ₹ 50 cr plus interest. <b>Guarantors</b> - Umesh Katti, Nikhil Katti and Mallikarjun Pujjar
State Bank of India	Harvesting & Transportation loan	October 04, 2018	4,000.00	3,708.00	9.25%	Within a maximum period of 365 days from the date of disbursement.	<b>Security</b> - Hypothecation of Receivables. <b>Corporate Guarantee</b> of VSIL <b>Guarantors</b> – All directors

<sup>(1)</sup> The amount has been sanctioned however the same was not disbursed as on March 31, 2019.

<sup>(2)</sup> Includes amount of Interest debited by the Bank on March 31, 2019

#### Details of Vehicle Loans

Name of the Lender	Sanctioned Amount (₹ in lakhs)	Amount Outstanding as on March 31, 2019	Rate of Interest (%)	Repayment Schedule	Security Created
BDCC Bank BB Loan Ashok Leyland	9.00	4.35	13.00%	Repayable in monthly installments of ₹ 0.15 lakhs each	Vehicle
BDCC Bank BB Loan Bolero Maxi 1	3.85	1.73	13.00%	Repayable in monthly installments of ₹ 0.06 lakhs each	Vehicle
BDCC Bank BB Loan Bolero Maxi 2	3.85	1.73	13.00%	Repayable in monthly installments of ₹ 0.06 lakhs each	Vehicle
BDCC Bank Loan 770 Case EX Loader	15.63	6.77	13.00%	Repayable in monthly installments of ₹ 0.26 lakhs each	Vehicle

(₹ in lakhs)

---

The aforesaid amounts sanctioned do not include sub-limit for amounts sanctioned towards Non-Fund based limits, including Letters of Credit (“LC”). Some of the limits are fungible between Fund based and non fund based facilities. We have obtained various Non-Fund based limits in the form of Letter of Credits (Domestic and Foreign) and Bank Guarantees.

During the currency of the facilities, without prior approval of the Lenders which shall not be unreasonably withheld, the Borrower (Vishwaraj Sugar Industries Limited) shall not:

- ✓ Formulate any scheme of amalgamation or merger or reconstruction
- ✓ Affect any adverse changes in company’s/firm’s capital structure
- ✓ Enter into any borrowing or non-borrowing arrangements either secured or unsecured with any bank, financial institution, company, firm or accept deposits in excess of the limits laid down by Reserve Bank of India.
- ✓ Undertake guarantee obligations on behalf of any other company/firm or person
- ✓ Declare dividend for any year except out of profits relating to that year after meeting all the financial commitments to the bank and making all due and necessary provisions
- ✓ Sell or dispose off or create security or encumbrances on the assets charged to the bank in favour of any other bank, financial institution, company, firm, individual.
- ✓ Repay monies brought in by the promoters, partners, directors, shareholders, their relatives and friends in the business of the company/firm by way of deposits/loans/share application money, etc.

The directors/ promoters should not withdraw the profits earned in the business /capital invested in the business without meeting the instalments(s) payable under the Term loan.



## SECTION VII – LEGAL AND OTHER REGULATORY INFORMATION

### OUTSTANDING LITIGATIONS AND MATERIAL DEVELOPMENTS

*Except as stated in this section, there are no:*

*A. (i) criminal proceedings; (ii) actions by statutory or regulatory authorities; (iii) claims relating to direct and indirect taxes; or (iv) Material Litigation (as defined below); involving our Company, Directors, Promoters or Group Companies. Our Board, in its meeting held on December 18, 2017 determined that all pending litigations involving our Company, Promoters, Directors, or Group Companies as the case may be, other than criminal proceedings, statutory or regulatory actions and taxation matters, would be considered material, where the monetary liability quantified exceeds 1% of the total Revenue of company as per latest full year audited financial or where the monetary liability is not quantifiable, each such case involving our Company, Promoters, Directors, or Group Companies, whose outcome would have a bearing on the operations or performance of our Company (“Material Litigation”).*

*B. (i) litigation or legal actions, pending or taken, by any Ministry or department of the Government or a statutory authority against our Promoters during the last five years; (ii) pending proceedings initiated against our Company for economic offences; (iv) default and non-payment of statutory dues by our Company; (v) inquiries, inspections or investigations initiated or conducted under the Companies Act, 2013 or any previous companies law in the last five years against our Company; or (vi) material frauds committed against our Company in the last five years.*

*C. (i) outstanding Material Dues (as defined below) to creditors; or (ii) outstanding dues to small scale undertakings and other creditors.*

*Our Board, in its meeting held on December 18, 2017, determined that all outstanding dues owed by the Company to small scale undertaking and other creditors exceeding 1% of the revenue of our Company as per the last audited financial statements shall be considered as material dues (“Material Dues”). Details of outstanding dues to creditors (including micro and small enterprises as defined under the Micro, Small and Medium Enterprises Development Act, 2006) as required under the SEBI ICDR Regulations have been disclosed on our website at [www.vsil.co.in](http://www.vsil.co.in)*

*Our Company, Directors, Promoters and Group Companies are not Wilful Defaulters and there have been no violations of securities laws in the past or pending against them.*

### CONTINGENT LIABILITIES OF OUR COMPANY

Particulars	As at March 31,				
	2019	2018	2017 (Proforma)	2016 (Proforma)	2015 (Proforma)
(a) Court Cases	1,506.15	1,253.66	1,182.31	2,061.99	1,847.84
(b) Bank Guarantee	57.00	143.78	110.28	115.50	58.50
(c) EPCG Export Obligation	289.99	289.99	289.99	-	-
	<b>1,853.14</b>	<b>1,649.43</b>	<b>1,582.58</b>	<b>2,177.49</b>	<b>1,906.34</b>

#### A. LITIGATION AGAINST OUR COMPANY

##### 1. Criminal matters

- a. Criminal Revision Petition bearing No. 100294/2016 filed by Appasab Shivappa Halijoli (“the Petitioner”) against the Company (“Accused”) before the High Court of Karnataka, Dharwad Bench (“the Court”).

The Company had issued an advance amount to the Accused for transportation of sugar during the harvest season of 2009-2010. However, the Complainant alleges that the accused failed to transport the sugarcane. Therefore, the Complainant requested the Accused to return the advance amount issued by the Company. On August 05, 2011, the Accused issued a cheque to the Company for the advance amount (including added interest) of ₹ 1,76,273/- (“the Cheque Amount”) which was returned by the bank on account of insufficient funds. Upon receiving no response from the Accused, the Complainant filed the aforesaid Criminal Complaint bearing No. 126/2012 before the Court *inter-alia* praying that the Court direct the Accused to pay the Cheque Amount at the earliest and be penalized for an amount which is double cheque Amount. On being aggrieved

by the Judgment and Order dated March 27, 2014 passed in Criminal Complaint no. 126/2012 before the Civil Judge, J.M.F.C. Court, the Petitioner further filed a Criminal Appeal bearing no. 57/2014 before the Hon'ble VII Additional District and Sessions Judge, Belagavi which as dismissed by vide Order dated October 13, 2016. However, the Petitioner has filed a Criminal Revision Petition bearing No. 100294/2016 before the Court inter-alia praying to call for the records, pleased to allow this Criminal Revision Petition and to set aside the judgment and order dated October 13, 2016 filed before the VII Additional District and Sessions Judge, Belagavi in Criminal Appeal no 57/2014 and also to set aside the judgment and order of conviction and sentence dated March 27, 2014 in Criminal Complaint no. 16/2012 passed by the Civil Judge and JMFC Court acquitting the Petitioner of the offences punishable under Section 138 of the Negotiable Instruments Act in the interest of justice and equity. This matter is currently pending.

## 2. Litigation Involving Actions by Statutory/Regulatory Authorities

### a. MVC No. 540/2017 in the matter between Shobha Pujeri & Ors v. the Company and Vidyadhar Dadasaheb Borade before the Motor Accident Claims Tribunal, Belagavi

A petition bearing no. 540/2017 has been filed before the Motor Accidents Claims Tribunal, Belagavi ("Tribunal") by Shobha Pujeri ("Petitioner") against Nikhil Umesh Katti, Managing Director of the Company and Vidyadhar Dadasaheb Borade under Section 166 of the Motor Vehicles Act, 1988 for claiming a compensation of ₹ 20,00,000/- (Rupees Twenty Lakh only) ("Claim Amount") along with interest at the rate of 18% per annum from the date of accident till the realization of the Claim Amount, for the death of her husband, due to a motor accident caused by the Company's vehicle. The matter is pending in the Tribunal.

### b. MVC No. 2321/2016 in the matter between M.A. Bicchunnavar v. the Company before the Motor Accident Claims Tribunal, Belagavi.

A petition bearing No. 2321/2016 has been filed before the Motor Accidents Claims Tribunal, Belagavi ("The Tribunal") by M.A. Bicchunnavar ("Petitioner") against the Nikhil Umesh Katti, Managing Director and Ors under Section 166 of the Motor Vehicles Act, 1988 for claiming a compensation of ₹5,00,000 (Rupees Five Lakh Only) ("The Claim Amount") for the physical injury arising out of a motor accident caused by motor vehicle of the Company. The matter is pending in the Tribunal.

### c. W.M.C No. 15/2016 in the matter between Sunita Waghmare & Anr. v. General Manager of the Company & Anr. before the Civil Judge and Workmen Compensation Officer Court, Beed

A suit bearing no. 15/2016 has been filed before Civil Judge and Workmen Compensation Officer Court, Beed ("Court") by Sunita Waghmare ("Applicant") against the General Manager of the Company for inter-alia claiming workman's compensation amounting to ₹ 6,77,760/- ("Compensation Amount") along with interest at the rate of 12% on the Compensation Amount, for the accidental death of her husband during the course of his employment with the Company. The matter is pending before the Court.

## 3. Litigation involving Tax Liabilities

### (i) Direct Tax Liabilities

NIL

### (ii) Indirect Taxes Liabilities

Sr. No.	Type of Direct Tax	No. of Cases	Amount in dispute/ demanded (in ₹)
1.	Central Excise	9	1,17,68,501/-
	<b>Total</b>	<b>9</b>	<b>1,17,68,501/-</b>

### 1. Show Cause Notice dated August 05, 2011 bearing No. 10/2011 issued by Superintendent of Central Excise, Belgaum Division ("the Superintendent") to Vishwanath Sugar and Steel Limited ("the Company").

The Superintendent had issued a show cause notice dated August 5, 2011 inter-alia requiring the Company to show cause as to why (i) CENVAT credit of ₹ 11,324/- on welding Electrodes availed for the period from July 2010 to January 2011 by the Company should not be demanded and recovered under Rule 14 of CENVAT

Credit Rules, 2004 and (ii) why interest and penalty on the same should not be imposed on the Company. Thereafter, the Company filed its reply on August 28, 2011. This matter is currently pending.

2. **Show Cause Notice dated January 29, 2008 bearing No. 10/2008 issued by Superintendent of Central Excise, Belgaum Division (“the Superintendent”) to Vishwanath Sugar and Steel Limited (“the Company”).**

The Superintendent had issued a show cause notice dated January 29, 2008 inter-alia requiring the Company to show cause as to why (i) CENVAT credit of ₹ 38,94,851/- should not be demanded and recovered under Rule 14 of CENVAT Credit Rules, 2004 read with section 11-A of the Central Excise Act, 1994 and (ii) why penalty under Rule 15 of the CENVAT on the same should not be imposed on the Company. Thereafter, the Company filed its reply on June 05, 2008. This matter is currently pending.

3. **Show Cause Notice dated April 29, 2009 bearing No. 14/2009 issued by the Assistant Commissioner of Central Excise, Belgaum (“the Commissioner”) to Vishwanath Sugars Limited (“the Company”).**

The Commissioner had issued a Show Cause Notice dated April 29, 2009 bearing No. 14/2009-(AC) (“SCN”) to the Company inter alia requiring our Company to show cause as to why (i) Cenvat credit of ₹ 0.28 lakhs (₹ 27,709) during the period from April 2008 to March 2009 should not be recovered from our Company along with interest thereon; (ii) interest at appropriate rate on the amount as demanded above, should not be charged, demanded and recovered under Section 11AB of the Central Excise Act, 1944 and (iii) Penalty under Rule 15 of the Cenvat Credit Rules, 2004 should not be imposed on our Company. The Company filed its reply vide dated May 19, 2009 inter alia requesting the Assistant Commissioner to vacate the SCN and drop the proceedings. This matter is currently pending

4. **Show Cause Notice dated April 08, 2008 bearing No. 40/2010 issued by the Additional Commissioner of Central Excise to Vishwanath Sugars Limited (“the Company”).**

The Additional Commissioner of Central Excise, Belgaum had issued a Show Cause Notice dated April 08, 2010 bearing No. 40/2010 (“SCN”) to the Company inter alia requiring our Company to show cause as to why (i) Cenvat credit of ₹ 17,49,305/- should not be demanded and recovered from the Company under Rule 14 of the Cenvat Credit Rules, 2004; (ii) the interest should not be recovered from the Company under Rule 14 of the Cenvat Credit Rules, 2004 and (iii) penalty should not be imposed on the Company under Rule 15 of the Cenvat Credit Rules, 2004. The Company filed its reply vide dated February 23, 2012 and May 22, 2015 inter alia requesting the Assistant Commissioner to vacate the SCN and drop the proceedings. Thereafter, The Joint Commissioner of the Central Excise and Customs, Belgaum filed a Corrigendum dated October 14, 2016 inter alia substituting the words “Additional/Joint Commissioner of Central Excise, Customs and Service Tax, No. 71, Club Road, Belgaum-590 001” with “The Deputy /Assistant Commissioner of Central Excise, Belgaum Division, Belgaum”. This matter is currently pending.

5. **Show Cause Notice dated October 17, 2012 bearing No. 37 of 2012 issued by the Assistant Commissioner of Central Excise, Belgaum Division to the Company.**

The Assistant Commissioner of Central Excise, Belgaum Division had issued a Show Cause Notice (“SCN”) dated October 17, 2012 inter alia requiring the Company to show cause as to why (i) Cenvat credit of ₹ 3,12,718/- (Rupees Three Lakhs Twelve Thousand and Seven Hundred and Eighteen only) during the period from December 2010 to September 2011 should not be recovered from the Company along with interest thereon; and (ii) Penalty under Section Rule 15 of the Cenvat Credit Rules, 2004 should not be imposed on the Company for these alleged violations. The Company submitted its reply to the aforementioned SCN by a letter dated November 30, 2012. The matter is currently pending before the Assistant Commissioner of Central Excise, Belgaum.

6. **Show Cause Notice dated September 23, 2008 bearing No. 80 of 2008 issued by the Joint Commissioner of Central Excise, Belgaum Division to the Company.**

The Joint Commissioner of Central Excise and Customs, Belgaum had issued a Show Cause Notice (“SCN”) dated September 23, 2008 inter alia requiring the Company to show cause as to why (i) Cenvat credit of ₹ 19,70,728 (Rupees Nineteen Lakhs Seventy Thousand Seven Hundred and Twenty-Eight only) during the period from September 2007 to July 2008 should not be demanded and recovered from them along with interest thereon; and (ii) Penalty under Rule 15 of the Cenvat Credit Rules, 2004 should not be imposed on the

Company for these alleged violations. The Company has submitted its reply to the aforementioned SCN by a letter dated June 22, 2009. The matter is currently pending before the Joint Commissioner of Central Excise, Belgaum.

**7. Show Cause Notice dated October 18, 2012 bearing No. 38 of 2012 issued by the Commissioner of Central Excise & Customs, Belgaum to the Company.**

The Commissioner of Central Excise & Customs, Belgaum issued a Show Cause Notice dated October 18, 2012 to the Company to show cause as to why (i) The amount of ₹ 4,87,691/- (ii) a proportionate Cenvat Credit to extent of 13.533% involved in production of steam used for generation of electricity and production of steam should not be demanded and recovered from the Company and (iii) interest and penalty on the same should not be imposed on the Company. The company filed a reply on November 30, 2012. The matter is currently pending.

**8. Show Cause Notice dated January 23, 2018 bearing No. 32 of 2017 issued by the Assistant Commissioner of Central Tax, Belgaum Division to the Company.**

The Assistant Commissioner of Central Tax, Belgaum Division had issued a **Show Cause Notice ("SCN")** dated January 23, 2018 inter alia requiring the Company to show cause as to why (i) an amount of ₹ 40,271 (Rupees forty thousand two hundred seventy one) during the period from January 2016 to March 2016 should not be recovered from the Company along with interest thereon; and (ii) Penalty under Section Rule 25 of the Central Excise Rules, 2002 read along with Section 11AC of The Central Excise Act, 1944 should not be imposed on the Company for these alleged violations. The Company submitted its reply to the aforementioned SCN by a letter dated April 9, 2018. Thereafter, the Assistant Commissioner of Central Excise, Customs and Service Tax, Belgaum passed an Order dated May 15, 2018 inter-alia (i) Confirming and ordering the recovery of ₹ 40,271; (ii) demanding interest under Section 11AA under Central Excise Act, 1944 (iii) imposing penalty of ₹ 5,000/- under Rule 25 of Central Excise Rules, 2002 read with Section 11AC (1) (a) of Central Excise Act, 1944. Thereafter, the Company presented an appeal before the Superintendent CGST and C. Ex inter alia praying the Order dated May 15, 2018 be set aside and any other relief be granted. Furthermore, an Order in Appeal issued by the Commissioner (Appeals) Central Tax, Belagavi allowed the appeal in their favour.

**9. Civil Appeal No. 013921-013922 filed by the Commissioner of Central Excise, Belgaum against the Company before the Supreme Court of India ("the Court")**

Vide an Order in Original No. 4/2005 (ADC) dated August 31, 2005, the Commissioner of Central Excise inter-alia demanded ₹ 32,73,904/- along with interest and penalties from the Company for wrongly availing Cenvat credit in respect of certain items used for construction of steel structure of the factory shed. Thereafter, on being aggrieved by the aforesaid Order, the Company filed an appeal bearing No. 322/05-CE before the Commissioner (Appeals) of Central Excise *inter-alia* praying to set aside the aforesaid Order dated August 31, 2005 and allow the appeal. Subsequently, vide Order in Appeal No. 322/05-CE dated December 09, 2015 by which the Commissioner (Appeals) of Central Excise inter-alia upheld the Order in Original No. 4/2005 (ADC) and rejected the aforesaid appeal. Consequently, the Company filed an Appeal No. E/169/2006 before the Customs, Excise, Service Tax Appellate Tribunal, South Zonal Bench, and Bangalore ("CESTAT") inter-alia praying to set aside the aforesaid Order in Appeal dated December 09, 2015 and allow the appeal. Vide Order dated February 14, 2008, CESTAT allowed the Company's Appeal. On being aggrieved by the aforesaid CESTAT order, the Commissioner of Central Excise, Belgaum filed C.E.A No. 61 of 2008 before the Hon'ble Karnataka High Court ("the High Court"). Vide Order dated August 18, 2011, the High Court dismissed the aforesaid appeal No. 61 of 2008. Further, on being aggrieved by the High Court Order, the Commissioner of Central Excise, Belgaum has filed the aforesaid Civil Appeal No. 013921-013922 before the Court inter-alia praying the Court to set aside the Order dated August 18, 2011 and allow the appeal. This matter is currently pending.

**4. Other Pending Litigations**

**a. CS (Comm) 646/2018 dated May 29, 2014 filed by M/s Allied Blenders and Distilleries Private Limited ("the Plaintiff") against (i) Sri Venkateshwara Distilleries and (ii) the Company ("the Defendants") before Delhi High Court ("the Court").**

An Ordinary Suit dated May 29, 2014 was filed by the Plaintiff before the Court for permanent injunction debarring the Defendants from use of the label "Our Choice" wherein the Plaintiff had prayed for a decree of



permanent injunction in respect of infringement of copyright, infringement of design and for restraining passing off along with leave to reserve the right under Order II, Rule 2 of Code of Civil Procedure, 1908. In pursuance of the above mentioned prayer, an ex-parte ad interim stay order was passed by the Court as on May 29, 2014 in the favour of the Plaintiff. Consequently, an application under Order 39, Rule 4 of Code of Civil Procedure, 1908 was filed by the Company to vacate the ex parte ad interim stay order passed by the Court May 29, 2014. In the interim, the Company adopted a new mark “Your’s Choice” and the Court passed a further Order dated September 27, 2017 under which the Company was enjoined from using the mark “Your’s Choice”. Further, on February 23, 2018 the aforesaid Ordinary Suit was converted from no. 1769 of 2014 to CS (Comm) 646/2018. This matter is currently pending before the Hon’ble Delhi High Court.

- b. Miscellaneous Appeal dated September 07, 2018 bearing no. 81 of 2018 filed by Joitba Birje (“the Plaintiff”) against Nikhil Umesh Katti, Managing Director of the Company and others (“the Respondent”) before the Principle Civil Judge and JMFC (“the Court”).**

Original Suit bearing No. 1330/ 2015 dated December 02, 2015 was filed by the Jotiba Birje against the Respondent for Declaration and Consequential relief of injunction against debarring the Respondent from use of the suit property in respect of Survey No. 56-3/1/2 measuring 22 Gunthas 08 Annas situated at Kadoli, Belagavi. I.A. was filed under Order XXXIX Rule 1 and 2 of C.P.C dated September 11, 2012 for restraining the Respondent from disturbing the possession of the Plaintiffs suit property was rejected. The Plaintiff filed an appeal before the Assistant Commissioner against the rejection of the above application filed under the RTS appeal No. 1433/2014-15 which was dismissed by the Assistant Commissioner on the ground of delay and asked the Plaintiff to approach the civil court to get an appropriate relief vide order dated July 07, 2015. However, as on the date of the filing of the I.A. there is no evidence stating the plaintiff to be in possession of the said suit property and hence the Court states there is no prima –facie case existed in favour of the Plaintiff and therefore the Court vide Order dated July 21, 2018 stated that I.A.NoI filed by the plaintiff under Order XXXIX Rule 1 and 22 of C.P.C is rejected with cost of ₹ 100/-. Since, the Original suit filed by the Plaintiff was rejected, the Petitioner preferred a Miscellaneous Appeal dated September 07, 2018 against the Respondent No. 1 before the Court. This matter is currently pending.

- c. Original Suit dated February 18, 2015 bearing No. 62/2015 filed by Suprita Inamdar (“the Plaintiff”) against Vishwaraj Developers a Partnership firm represented by its authorised partner Nikhil Umesh Katti (“the Defendant No. 3”) before the Principle Senior Civil Judge and CJM (“the Court”).**

Original Suit dated February 18, 2015 bearing No. 62/015 was filed by the Plaintiff before the Court against the Defendant No. 3 for relief of Declaration, partition and separate possession in respect of ancestral properties, joint family properties and inherited properties. Since, the Defendant No. 3 was not in joint possession of the suit schedule properties, the suit was valued at ₹ 1,02,75,000/- (Rupees One Crore two Lakhs and Seventy Five Thousand Only) under Section 35(2) of Karnataka Court Fees and Suit Valuation Act being the value of the Plaintiff’s share in the suit schedule properties. Therefore, the Plaintiff *inter-alia* praying to the Court to pass a decree, declaring 1/3<sup>rd</sup> of the share to the Plaintiff in the scheduled properties by way of partition and separate possession, by declaring the sale deeds executed by the deceased, wherein Defendant No. 3 is not binding on the Plaintiff’s legitimate share, to award the costs of the suit, to grant permission to amend the plaint if necessary and to grant any other equitable relief the Plaintiff is found entitled to. This matter is currently pending before the Court.

## **B. CASES FILED BY OUR COMPANY**

### **1. Litigation Involving Criminal matters**

- a. Criminal Complaint dated June 12, 2018 bearing No. 567/2018 filed by the Company against Jaganath Sitaram Ghule (“the Accused”) before the Court of J.M.F.C, Hukkeri (“the Court”).**

The Company had issued an advance amount to the Accused for transportation of sugar during the harvest season of 2017-18. However, the Complainant alleges that the accused failed to transport the sugarcane. Therefore, the Complainant requested the Accused to return the advance amount issued by the Company. On March 21, 2018, the Accused issued a cheque to the Company for the advance amount of ₹ 10,98,959/- (“the Cheque Amount”) which was returned by the bank on account of insufficient funds. Subsequently, the Company issued a legal notice dated April 26, 2018 to the Accused requiring the Accused to pay ₹ 10,98,959/- at the earliest. Upon receiving no response from the Accused, the Complainant filed the aforesaid Criminal Complaint bearing No. 567/2018 before the Court *inter-alia* praying that the Court direct the Accused to pay

the Cheque Amount at the earliest and be penalized for an amount which is double cheque Amount. This matter is currently pending.

**b. Criminal Complaint dated June 12, 2018 bearing No. 568/2018 filed by the Company against Ashok Vaman Javale (“the Accused”) before the Court of J.M.F.C, Hukkeri (“the Court”).**

The Company had issued an advance amount to the Accused for transportation of sugar during the harvest season of 2017-18. However, the Complainant alleges that the accused failed to transport the sugarcane. Therefore, the Complainant requested the Accused to return the advance amount issued by the Company. On March 21, 2018, the Accused issued a cheque to the Company for the advance amount of ₹ 3,28,652/- (“the Cheque Amount”) which was returned by the bank on account of insufficient funds. Subsequently, the Company issued a legal notice dated April 26, 2018 to the Accused requiring the Accused to pay ₹ 3,28,652/- at the earliest. Upon receiving no response from the Accused, the Complainant filed the aforesaid **Criminal Complaint** bearing No. 87/2018 before the Court *inter-alia* praying that the Court direct the Accused to pay the Cheque Amount at the earliest and be penalized for an amount which is double cheque Amount. This matter is currently pending.

**c. Criminal Complaint dated June 13, 2018 bearing No.574/2018 filed by the Company against Laxman Manashing Pawar (“the Accused”) before the Court of J.M.F.C, Hukkeri (“the Court”).**

The Company had issued an advance amount to the Accused for transportation of sugar during the harvest season of 2017-18. However, the Complainant alleges that the accused failed to transport the sugarcane. Therefore, the Complainant requested the Accused to return the advance amount issued by the Company. On March 21, 2018, the Accused issued a cheque to the Company for the advance amount of ₹ 5,49,479/- (“the Cheque Amount”) which was returned by the bank on account of insufficient funds. Subsequently, the Company issued a legal notice dated April 26, 2018 to the Accused requiring the Accused to pay ₹ 5,49,479/- at the earliest. Upon receiving no response from the Accused, the Complainant filed the aforesaid **Criminal Complaint** bearing No. 574/2018 before the Court *inter-alia* praying that the Court direct the Accused to pay the Cheque Amount at the earliest and be penalized for an amount which is double cheque Amount. This matter is currently pending.

**d. Criminal Complaint dated June 13, 2018 bearing No. 575/2018 filed by the Company against Devidas Dhanasing Jadhav (“the Accused”) before the Court of J.M.F.C, Hukkeri (“the Court”).**

The Company had issued an advance amount to the Accused for transportation of sugar during the harvest season of 2017-18. However, the Complainant alleges that the accused failed to transport the sugarcane. Therefore, the Complainant requested the Accused to return the advance amount issued by the Company. On March 21, 2018, the Accused issued a cheque to the Company for the advance amount of ₹ 5,49,479/- (“the Cheque Amount”) which was returned by the bank on account of insufficient funds. Subsequently, the Company issued a legal notice dated April 26, 2018 to the Accused requiring the Accused to pay ₹ 5,49,479/- at the earliest. Upon receiving no response from the Accused, the Complainant filed the aforesaid **Criminal Complaint** bearing No. 575/2018 before the Court *inter-alia* praying that the Court direct the Accused to pay the Cheque Amount at the earliest and be penalized for an amount which is double cheque Amount. This matter is currently pending.

**e. Criminal Complaint dated June 13, 2018 bearing No. 576/2018 filed by the Company against Tanaji Shymarao Pawar (“the Accused”) before the Court of J.M.F.C, Hukkeri (“the Court”).**

The Company had issued an advance amount to the Accused for transportation of sugar during the harvest season of 2017-18. However, the Complainant alleges that the accused failed to transport the sugarcane. Therefore, the Complainant requested the Accused to return the advance amount issued by the Company. On March 21, 2018, the Accused issued a cheque to the Company for the advance amount of ₹ 5,49,479/- (“the Cheque Amount”) which was returned by the bank on account of insufficient funds. Subsequently, the Company issued a legal notice dated April 26, 2018 to the Accused requiring the Accused to pay ₹ 5,49,479/- at the earliest. Upon receiving no response from the Accused, the Complainant filed the aforesaid **Criminal Complaint** bearing No. 576/2018 before the Court *inter-alia* praying that the Court direct the Accused to pay the Cheque Amount at the earliest and be penalized for an amount which is double cheque Amount. This matter is currently pending.

- f. **Criminal Complaint dated June 13, 2018 bearing No. 578/2018 filed by the Company against Ramadhan Ashokrao Chate (“the Accused”) before the Court of J.M.F.C, Hukkeri (“the Court”).**

The Company had issued an advance amount to the Accused for transportation of sugar during the harvest season of 2017-18. However, the Complainant alleges that the accused failed to transport the sugarcane. Therefore, the Complainant requested the Accused to return the advance amount issued by the Company. On March 21, 2018, the Accused issued 3 cheques to the Company for the total advance amount of ₹ 1,11,449/- (“the Cheque Amount”) which was returned by the bank on account of insufficient funds. Subsequently, the Company issued a legal notice dated April 26, 2018 to the Accused requiring the Accused to pay ₹ 1,11,449/- at the earliest. Upon receiving no response from the Accused, the Complainant filed the aforesaid **Criminal** Complaint bearing No. 578/2018 before the Court *inter-alia* praying that the Court direct the Accused to pay the Cheque Amount at the earliest and be penalized for an amount which is double cheque Amount. This matter is currently pending.

- g. **Criminal Complaint dated November 24, 2018 bearing No. 36/2019 filed by the Company against Venkati Narayan Gopalagare (“the Accused”) before the Court of J.M.F.C, Hukkeri (“the Court”).**

The Company had issued an advance amount to the Accused for transportation of sugar during the harvest season of 2016-17. However, the Complainant alleges that the accused failed to transport the sugarcane. Therefore, the Complainant requested the Accused to return the advance amount issued by the Company. On September 07, 2018, the Accused issued a cheque to the Company for the advance amount of ₹ 2,68,722/- (“the Cheque Amount”) which was returned by the bank on account of insufficient funds. Subsequently, the Company issued a legal notice dated October 09, 2018 to the Accused requiring the Accused to pay ₹ 2,68,722/- at the earliest. Upon receiving no response from the Accused, the Complainant filed the aforesaid **Criminal** Complaint bearing No. 190/2018 before the Court *inter-alia* praying that the Court direct the Accused to pay the Cheque Amount at the earliest and be penalized for an amount which is double cheque Amount. This matter is currently pending.

- h. **Criminal Complaint dated November 24, 2018 bearing No. 37/2019 filed by the Company against Bhagawant Bhagawan Gore (“the Accused”) before the Court of J.M.F.C, Hukkeri (“the Court”).**

The Company had issued an advance amount to the Accused for transportation of sugar during the harvest season of 2016-17. However, the Complainant alleges that the accused failed to transport the sugarcane. Therefore, the Complainant requested the Accused to return the advance amount issued by the Company. On September 07, 2018, the Accused issued a cheque to the Company for the advance amount of ₹ 4,19,096/- (“the Cheque Amount”) which was returned by the bank on account of insufficient funds. Subsequently, the Company issued a legal notice dated October 09, 2018 to the Accused requiring the Accused to pay ₹ 4,19,096/- at the earliest. Upon receiving no response from the Accused, the Complainant filed the aforesaid **Criminal** Complaint bearing No. 37/2019 before the Court *inter-alia* praying that the Court direct the Accused to pay the Cheque Amount at the earliest and be penalized for an amount which is double cheque Amount. This matter is currently pending. Note: 37/19

- i. **Criminal Complaint dated June 13, 2018 bearing No. 579/2018 filed by the Company against Uttareshwar Mahadev Lad (“the Accused”) before the Court of J.M.F.C, Hukkeri (“the Court”).**

The Company had issued an advance amount to the Accused for transportation of sugar during the harvest season of 2017-18. However, the Complainant alleges that the accused failed to transport the sugarcane. Therefore, the Complainant requested the Accused to return the advance amount issued by the Company. On March 21, 2018, the Accused issued a cheque to the Company for the advance amount of ₹ 1,11,449/- (“the Cheque Amount”) which was returned by the bank on account of insufficient funds. Subsequently, the Company issued a legal notice dated April 26, 2018 to the Accused requiring the Accused to pay ₹ 1,11,449/- at the earliest. Upon receiving no response from the Accused, the Complainant filed the aforesaid **Criminal** Complaint bearing No. 579/2018 before the Court *inter-alia* praying that the Court direct the Accused to pay the Cheque Amount at the earliest and be penalized for an amount which is double cheque Amount. This matter is currently pending.



- j. Criminal Revision Petition bearing No. 47/2017 filed by against Bhimasen Sabu Pujeri (“Accused”) before the Court of Hon’ble Principle District and Sessions Judge, Belgavi, Belgavi (“the Court”).**

The Company has filed a Criminal Revision Petition bearing no. 47/2017 before the Court against the Accused on being aggrieved by the Order passed by Hon’ble J.M.F.C. Court, Sankeshwar in Private Complaint bearing no. 19/2015 dated July 21, 2016 under Section 397 of the Criminal Procedure Code, 1973 whereby the Hon’ble J.M.F.C. Court Sankeshwar dismissed the Private Complaint no. 19 of 2015 for non – prosecution. The Company vide this aforesaid Criminal Revision Petition bearing no. 47/2017 *inter-alia* prays that the Court be pleased to set aside the Order passed by Hon’ble J.M.F.C. Court, Sankeshwar and allow this Criminal Revision Petition. This matter is currently pending.

- k. Private Complaint bearing No. 15/2016 filed by the Company (“the Complainant”) against Pralhad Chandrakant Bhondave (“the Accused”) before the Court of J.M.F.C, Hukkeri (“the Court”).**

The Company had issued an advance amount to the Accused for transportation of sugar during the harvest season of 2012-2013. However, the Complainant alleges that the accused failed to transport the sugarcane. Therefore, the Complainant requested the Accused to return the advance amount issued by the Company. Thereafter, the Accused issued a cheque to the Company for the advance amount of ₹ 2,66,796/- (“**the Cheque Amount**”) which was returned by the bank on account of insufficient funds. Subsequently, the Company issued a legal notice dated October 8, 2013 to the Accused requiring the Accused to pay ₹ 2,66,796/- at the earliest. Upon receiving no response from the Accused, the Complainant filed the aforesaid Private Complaint bearing No. 15/2016 before the Court *inter-alia* praying that the Court direct the Accused to pay the Cheque Amount at the earliest and be penalized for an amount which is double cheque Amount. This matter is currently pending.

- l. Criminal Complaint dated November 21, 2018 bearing No. 52/2019 filed by the Company (the “Complainant”) against Shri. Bharat Ashruba Jadhav (“the Accused”) before the Court of J.M.F.C, Hukkeri (“the Court”).**

The Accused had executed an agreement bond with respect to the transportation and harvesting of sugarcane to the Complainant factory for the harvest season 2016-2017 and the Complainant had issued an advance amount for the same. However, the Complainant alleges that the Accused failed to transport the sugarcane and hence committing a breach of contract. Hence the Complainant requested the Accused to return the advance amount and interest amounting to ₹ 4,19,096/- However, the cheque issued in this respect by the Complainant bearing cheque no. 513588 was dishonored due to insufficient funds. Inter-alia the cause of action arose when the legal notice dated October 9, 2018 was sent to the Accused and he failed to pay the Complainant issued a legal notice dated October 9, 2018 and he failed to pay the cheque amount within the stipulated time period mentioned. Hence the aforesaid complaint was filed by the Complainant *inter-alia* praying that the accused had committed an offence u/s. 138 of Negotiable Instrument Act and hence the accused shall be penalized for double the amount of cheque and out of the penalty amount to be paid to the complainant society along with collection charges and an devotes fees of ₹ 3000/- and other expenses.

- m. Criminal Complaint dated November 28, 2018 bearing No. 51/2019 filed by the Company (the “Complainant”) against Shri. Sitaram Shankar Jogdand (“the Accused”) before the Court of J.M.F.C, Hukkeri (“the Court”).**

The Accused had executed an agreement bond with respect to the transportation and harvesting of sugarcane to the Complainant factory for the harvest season 2016-2017 and the Complainant had issued an advance amount for the same. However, the Complainant alleges that the Accused failed to transport the sugarcane and hence committing a breach of contract. Hence the Complainant requested the Accused to return the advance amount and interest amounting to ₹ 4,19,096/- However, the cheque issued in this respect by the Complainant bearing cheque no. 000003 was dishonored due to insufficient funds. Inter-alia the cause of action arose when the legal notice dated October 9, 2018 was sent to the Accused and he failed to pay the Complainant issued a legal notice dated October 9, 2018 which was allegedly not received and he failed to pay the cheque amount within the stipulated time period mentioned. Hence the aforesaid complaint was filed by the Complainant *inter-alia* praying that the accused had committed an offence u/s. 138 of Negotiable Instrument Act and hence the accused shall be penalized for double the amount of cheque and out of the penalty amount to be paid to the complainant society along with collection charges and an devotes fees of ₹ 3000/- and other expenses.

- n. Criminal Complaint dated November 28 bearing No. 50/2019 filed by the Company (the “Complainant”) against Shri. Parameshwar Bahusaheb Mengade (“the Accused”) before the Court of J.M.F.C, Hukkeri (“the Court”).**

The Accused had executed an agreement bond with respect to the transportation and harvesting of sugarcane to the Complainant factory for the harvest season 2016-2017 and the Complainant had issued an advance amount for the same. However, the Complainant alleges that the Accused failed to transport the sugarcane and hence committing a breach of contract. Hence the Complainant requested the Accused to return the advance amount and interest amounting to ₹ 4,19,096/- However, the cheque issued in this respect by the Complainant bearing cheque no. 138199 was dishonored due to insufficient funds. Inter-alia the cause of action arose when the legal notice dated October 9, 2018 was sent to the Accused and he failed to pay the Complainant issued a legal notice dated October 9, 2018 which was allegedly not received and he failed to pay the cheque amount within the stipulated time period mentioned. Hence the aforesaid complaint was filed by the Complainant inter-alia praying that the accused had committed an offence u/s. 138 of Negotiable Instrument Act and hence the accused shall be penalized for double the amount of cheque and out of the penalty amount to be paid to the complainant society along with collection charges and an devotes fees of ₹ 3000/- and other expenses.

- o. Criminal Complaint dated November 24, 2018 bearing No. 42/2019 filed by the Company (the “Complainant”) against Shri. Bhasaheb Tulsiram Bhavar (“the Accused”) before the Court of J.M.F.C, Hukkeri (“the Court”).**

The Accused had executed an agreement bond with respect to the transportation and harvesting of sugarcane to the Complainant factory for the harvest season 2016-2017 and the Complainant had issued an advance amount for the same. However, the Complainant alleges that the Accused failed to transport the sugarcane and hence committing a breach of contract. Hence the Complainant requested the Accused to return the advance amount and interest amounting to ₹ 8,38,192/- However, the cheque issued in this respect by the Complainant bearing cheque no. 998372 was dishonored due to insufficient funds. Inter-alia the cause of action arose when the legal notice dated October 9, 2018 was sent to the Accused and he failed to pay the cheque amount within the stipulated time period mentioned in the legal notice. Hence the aforesaid complaint was filed by the Complainant inter-alia praying that the accused had committed an offence u/s. 138 of Negotiable Instrument Act and hence the accused shall be penalized for double the amount of cheque and out of the penalty amount to be paid to the complainant society along with collection charges and an devotes fees of ₹ 3,000/- and other expenses.

- p. Criminal Complaint dated November 28, 2018 bearing No. 49/2019 filed by the Company (the “Complainant”) against Shri. Padurang Baliram Das (“the Accused”) before the Court of J.M.F.C, Hukkeri (“the Court”).**

The Accused had executed an agreement bond with respect to the transportation and harvesting of sugarcane to the Complainant factory for the harvest season 2016-2017 and the Complainant had issued an advance amount for the same. However, the Complainant alleges that the Accused failed to transport the sugarcane and hence committing a breach of contract. Hence the Complainant requested the Accused to return the advance amount and interest amounting to ₹ 8,38,192/- However, the cheque issued in this respect by the Complainant bearing cheque no. 193341 was dishonored due to insufficient funds. Inter-alia the cause of action arose when a legal notice dated October 9, 2018 was sent to the Accused and he failed to pay the cheque amount within the stipulated time period mentioned in the legal notice and neither was there any reply. Hence the aforesaid complaint was filed by the Complainant inter-alia praying that the accused had committed an offence u/s. 138 of Negotiable Instrument Act and hence the accused shall be penalized for double the amount of cheque and out of the penalty amount to be paid to the complainant society along with collection charges and an devotes fees of ₹ 3,000/- and other expenses.

- q. Criminal Complaint dated December 12, 2018 bearing No. 43/2019 filed by the Company (the “Complainant”) against Shri. Shivaji Tulsiram Shinde and Bhagavat Bajaguli Patardi (“the Accused”) before the Court of J.M.F.C, Hukkeri (“the Court”).**

The Accused had executed an agreement bond with respect to the transportation and harvesting of sugarcane to the Complainant factory for the harvest season 2017-18 and the Complainant had issued an advance amount for the same. However, the Complainant alleges that the Accused failed to transport the sugarcane and hence committing a breach of contract. Hence the Complainant requested the Accused to return the advance amount and interest amounting to ₹ 51,33,992/-. However, the cheque issued in this respect by the Complainant was

dishonored due to insufficient funds. Inter-alia the cause of action arose when a legal notice dated November 2, 2018 was sent to the Accused and he failed to pay the cheque amount within the stipulated time period mentioned in the legal notice and neither was there any reply. Hence the aforesaid complaint was filed by the Complainant inter-alia praying that the accused had committed an offence u/s. 138 of Negotiable Instrument Act and hence the accused shall be penalized for double the amount of cheque and out of the penalty amount to be paid to the complainant society along with collection charges and an devotees fees of ₹ 3,000/- and other expenses.

- r. **Criminal Complaint dated November 27, 2018 bearing No. 41/2019 filed by the Company (the “Complainant”) against Shri. Chhagan Elarnath Kshirasagar (“the Accused”) before the Court of J.M.F.C, Hukkeri (“the Court”).**

The Accused had executed an agreement bond with respect to the transportation and harvesting of sugarcane to the Complainant factory for the harvest season 2016-17 and the Complainant had issued an advance amount for the same. However, the Complainant alleges that the Accused failed to transport the sugarcane and hence committing a breach of contract. Hence the Complainant requested the Accused to return the advance amount and interest amounting to ₹ 2,14,879/-. However, the cheque issued in this respect by the Complainant bearing cheque no. 053189 was dishonored due to insufficient funds. Inter-alia the cause of action arose when a legal notice dated November 2, 2018 was sent to the Accused and he failed to pay the cheque amount within the stipulated time period mentioned in the legal notice and neither was there any reply. Hence the aforesaid complaint was filed by the Complainant inter-alia praying that the accused had committed an offence u/s. 138 of Negotiable Instrument Act and hence the accused shall be penalized for double the amount of cheque and out of the penalty amount to be paid to the complainant society along with collection charges and an devotees fees of ₹ 3,000/- and other expenses.

- s. **Criminal Complaint dated November 27, 2018 bearing No. 40/2019 filed by the Company (the “Complainant”) against Shri. Janardhan Bhagawan Tonde (“the Accused”) before the Court of J.M.F.C, Hukkeri (“the Court”).**

The Accused had executed an agreement bond with respect to the transportation and harvesting of sugarcane to the Complainant factory for the harvest season 2016-17 and the Complainant had issued an advance amount for the same. However, the Complainant alleges that the Accused failed to transport the sugarcane and hence committing a breach of contract. Hence the Complainant requested the Accused to return the advance amount and interest amounting to ₹ 4,19,096/-. However, the cheque issued in this respect by the Complainant bearing cheque no. 003746 was dishonored due to insufficient funds. Inter-alia the cause of action arose when a legal notice dated October 9, 2018 was sent to the Accused and he failed to pay the cheque amount within the stipulated time period mentioned in the legal notice. Hence the aforesaid complaint was filed by the Complainant inter-alia praying that the accused had committed an offence u/s. 138 of Negotiable Instrument Act and hence the accused shall be penalized for double the amount of cheque and out of the penalty amount to be paid to the complainant society along with collection charges and an devotees fees of ₹ 3,000/- and other expenses.

- t. **Criminal Complaint dated November 27, 2018 bearing No. 39/2019 filed by the Company (the “Complainant”) against Shri. Rajabahu Sopanarao Soundaramal (“the Accused”) before the Court of J.M.F.C, Hukkeri (“the Court”).**

The Accused had executed an agreement bond with respect to the transportation and harvesting of sugarcane to the Complainant factory for the harvest season 2016-2017 and the Complainant had issued an advance amount for the same. However, the Complainant alleges that the Accused failed to transport the sugarcane and hence committing a breach of contract. Hence the Complainant requested the Accused to return the advance amount and interest amounting to ₹ 2,67,689/-. However, the cheque issued in this respect by the Complainant bearing cheque no. 000028 was dishonored due to insufficient funds. Inter-alia the cause of action arose when a legal notice dated October 9, 2018 was sent to the Accused and he failed to pay the cheque amount within the stipulated time period mentioned in the legal notice. Hence the aforesaid complaint was filed by the Complainant inter-alia praying that the accused had committed an offence u/s. 138 of Negotiable Instrument Act and hence the accused shall be penalized for double the amount of cheque and out of the penalty amount to be paid to the complainant society along with collection charges and an devotees fees of ₹ 3,000/- and other expenses.

- u. **Criminal Complaint dated November 27, 2018 bearing No. 38/2019 filed by the Company (the “Complainant”) against Shri. Rajebhau Dnyanoba Tidke (“the Accused”) before the Court of J.M.F.C, Hukkeri (“the Court”).**

The Accused had executed an agreement bond with respect to the transportation and harvesting of sugarcane to the Complainant factory for the harvest season 2016-17 and the Complainant had issued an advance amount for the same. However, the Complainant alleges that the Accused failed to transport the sugarcane and hence committing a breach of contract. Hence the Complainant requested the Accused to return the advance amount and interest amounting to ₹ 2,83,540. However, the cheque issued by the Accused in this respect to the Complainant bearing cheque no. 596613 was bounced and returned unencashed with an endorsement that “payment stopped by Drawer” vide intimation date September 18, 2018. Inter-alia the cause of action arose when a legal notice dated October 9, 2018 was sent to the Accused and he failed to pay the cheque amount within the stipulated time period mentioned in the legal notice. Hence the aforesaid complaint was filed by the Complainant inter-alia praying that the accused had committed an offence u/s. 138 of Negotiable Instrument Act and hence the accused shall be penalized for double the amount of cheque and out of the penalty amount to be paid to the complainant society along with collection charges and an devotees fees of ₹ 3,000/- and other expenses.

- v. **Criminal Complaint bearing No. 554/2018 filed by the Company (“the Complainant”) against Amit Shrirang Shinde (“the Accused”) before the Court of J.M.F.C, Hukkeri (“the Court”).**

The Company had issued an advance amount to the Accused for transportation of sugar during the harvest season of 2017-2018. However, the Complainant alleges that the accused failed to transport the sugarcane. Therefore, the Complainant requested the Accused to return the advance amount issued by the Company. On March 21, 2018, the Accused issued a cheque to the Company for the advance amount (including added interest) of ₹ 7 49,905/- (“the Cheque Amount”) which was returned by the bank on account of insufficient funds. Subsequently, the Company issued a legal notice dated April 26, 2018 to the Accused requiring the Accused to pay ₹ 7,49,905/- at the earliest. Upon receiving no response from the Accused, the Complainant filed the aforesaid Criminal Complaint bearing No. 554/2018 before the Court inter-alia praying that the Court direct the Accused to pay the Cheque Amount at the earliest and be penalized for an amount which is double cheque Amount. This matter is currently pending.

- w. **Criminal Complaint bearing No. 566/2018 filed by the Company (“the Complainant”) against Ankush Vilas Gosavi (“the Accused”) before the Court of J.M.F.C, Hukkeri (“the Court”).**

The Company had issued an advance amount to the Accused for transportation of sugar during the harvest season of 2017-2018. However, the Complainant alleges that the accused failed to transport the sugarcane. Therefore, the Complainant requested the Accused to return the advance amount issued by the Company. On March 21, 2018, the Accused issued a cheque to the Company for the advance amount (including added interest) of ₹ 4,77,818/- (“the Cheque Amount”) which was returned by the bank on account of insufficient funds. Subsequently, the Company issued a legal notice dated April 26, 2018 to the Accused requiring the Accused to pay ₹ 4,77,818/- at the earliest. Upon receiving no response from the Accused, the Complainant filed the aforesaid Criminal Complaint bearing No. 566/2018 before the Court inter-alia praying that the Court direct the Accused to pay the Cheque Amount at the earliest and be penalized for an amount which is double cheque Amount. This matter is currently pending.

- x. **Criminal Complaint bearing No. 565/2018 filed by the Company (“the Complainant”) against Baluhari Shirpati Naikwada (“the Accused”) before the Court of J.M.F.C, Hukkeri (“the Court”).**

The Company had issued an advance amount to the Accused for transportation of sugar during the harvest season of 2017-2018. However, the Complainant alleges that the accused failed to transport the sugarcane. Therefore, the Complainant requested the Accused to return the advance amount issued by the Company. On March 21, 2018, the Accused issued a cheque to the Company for the advance amount (including added interest) of ₹ 3,29,688/- (“the Cheque Amount”) which was returned by the bank on account of insufficient funds. Subsequently, the Company issued a legal notice dated April 26, 2018 to the Accused requiring the Accused to pay ₹ 3,29,688/- at the earliest. Upon receiving no response from the Accused, the Complainant filed the aforesaid Criminal Complaint bearing No. 565/2018 before the Court inter-alia praying that the Court direct the Accused to pay the Cheque Amount at the earliest and be penalized for an amount which is double cheque Amount. This matter is currently pending.



- y. **Criminal Complaint bearing No. 556/2018 filed the Company (“the Complainant”) against Bhimrao Damodar Thonde (“the Accused”) before the Court of J.M.F.C, Hukkeri (“the Court”).**

The Company had issued an advance amount to the Accused for transportation of sugar during the harvest season of 2017-2018. However, the Complainant alleges that the accused failed to transport the sugarcane. Therefore, the Complainant requested the Accused to return the advance amount issued by the Company. On March 21, 2018, the Accused issued a cheque to the Company for the advance amount (including added interest) of ₹ 4,39, 584/- (“the Cheque Amount”) which was returned by the bank on account of insufficient funds. Subsequently, the Company issued a legal notice dated April 26, 2018 to the Accused requiring the Accused to pay ₹ 4,39, 584/- at the earliest. Upon receiving no response from the Accused, the Complainant filed the aforesaid Criminal Complaint bearing No. 556/2018 before the Court inter-alia praying that the Court direct the Accused to pay the Cheque Amount at the earliest and be penalized for an amount which is double cheque Amount. This matter is currently pending.

- z. **Criminal Complaint bearing No. 555/2018 filed by the Company (“the Complainant”) against Mahadev Baban Bade (“the Accused”) before the Court of J.M.F.C, Hukkeri (“the Court”).**

The Company had issued an advance amount to the Accused for transportation of sugar during the harvest season of 2017-2018. However, the Complainant alleges that the accused failed to transport the sugarcane. Therefore, the Complainant requested the Accused to return the advance amount issued by the Company. On March 21, 2018, the Accused issued a cheque to the Company for the advance amount (including added interest) of ₹ 2,69, 041/- (“the Cheque Amount”) which was returned by the bank on account of insufficient funds. Subsequently, the Company issued a legal notice dated April 26, 2018 to the Accused requiring the Accused to pay ₹ 2,69,041/- at the earliest. Upon receiving no response from the Accused, the Complainant filed the aforesaid Criminal Complaint bearing No.555/2018 before the Court inter-alia praying that the Court direct the Accused to pay the Cheque Amount at the earliest and be penalized for an amount which is double cheque Amount. This matter is currently pending.

- aa. **Criminal Complaint bearing No. 557/2018 filed by the Company (“the Complainant”) against Namdev Ramabahu Walekar (“the Accused”) before the Court of J.M.F.C, Hukkeri (“the Court”).**

The Company had issued an advance amount to the Accused for transportation of sugar during the harvest season of 2017-2018. However, the Complainant alleges that the accused failed to transport the sugarcane. Therefore, the Complainant requested the Accused to return the advance amount issued by the Company. On March 21, 2018, the Accused issued a cheque to the Company for the advance amount (including added interest) of ₹ 5,03,852/- (“the Cheque Amount”) which was returned by the bank on account of insufficient funds. Subsequently, the Company issued a legal notice dated April 26, 2018 to the Accused requiring the Accused to pay ₹ 5,03,852/- at the earliest. Upon receiving no response from the Accused, the Complainant filed the aforesaid Criminal Complaint bearing No. 557/2018 before the Court inter-alia praying that the Court direct the Accused to pay the Cheque Amount at the earliest and be penalized for an amount which is double cheque Amount. This matter is currently pending.

- bb. **Criminal Complaint bearing No. 477/2018 filed by the Company (“the Complainant”) against Shatrugna Shiranga Gidde (“the Accused”) before the Court of J.M.F.C, Hukkeri (“the Court”).**

The Company had issued an advance amount to the Accused for transportation of sugar during the harvest season of 2017-2018. However, the Complainant alleges that the accused failed to transport the sugarcane. Therefore, the Complainant requested the Accused to return the advance amount issued by the Company. On March 21, 2018, the Accused issued a cheque to the Company for the advance amount (including added interest) of ₹ 16,21,685/- (“the Cheque Amount”) which was returned by the bank on account of insufficient funds. Subsequently, the Company issued a legal notice dated April 26, 2018 to the Accused requiring the Accused to pay ₹ 7,49,905/- at the earliest. Upon receiving no response from the Accused, the Complainant filed the aforesaid Criminal Complaint bearing No. 477/2018 before the Court inter-alia praying that the Court direct the Accused to pay the Cheque Amount at the earliest and be penalized for an amount which is double cheque Amount. This matter is currently pending.

**cc. Criminal Complaint bearing No. 564/2018 filed by the Company (“the Complainant”) against Sadashiv Mahadev Bade (“the Accused”) before the Court of J.M.F.C, Hukkeri (“the Court”).**

The Company had issued an advance amount to the Accused for transportation of sugar during the harvest season of 2017-2018. However, the Complainant alleges that the accused failed to transport the sugarcane. Therefore, the Complainant requested the Accused to return the advance amount issued by the Company. On March 21, 2018, the Accused issued a cheque to the Company for the advance amount (including added interest) of ₹ 3,92,170/- (“the Cheque Amount”) which was returned by the bank on account of insufficient funds. Subsequently, the Company issued a legal notice dated April 26, 2018 to the Accused requiring the Accused to pay ₹ 3,92,170/- at the earliest. Upon receiving no response from the Accused, the Complainant filed the aforesaid Criminal Complaint bearing No. 564/2018 before the Court inter-alia praying that the Court direct the Accused to pay the Cheque Amount at the earliest and be penalized for an amount which is double cheque Amount. This matter is currently pending.

**dd. Criminal Complaint bearing No. 478/2018 filed by the Company (“the Complainant”) against Sugreev Manik Karad (“the Accused”) before the Court of J.M.F.C, Hukkeri (“the Court”).**

The Company had issued an advance amount to the Accused for transportation of sugar during the harvest season of 2017-2018. However, the Complainant alleges that the accused failed to transport the sugarcane. Therefore, the Complainant requested the Accused to return the advance amount issued by the Company. On March 21, 2018, the Accused issued a cheque to the Company for the advance amount (including added interest) of ₹ 21,97,918/- (“the Cheque Amount”) which was returned by the bank on account of insufficient funds. Subsequently, the Company issued a legal notice dated April 26, 2018 to the Accused requiring the Accused to pay ₹ 21,97,918/- at the earliest. Upon receiving no response from the Accused, the Complainant filed the aforesaid Criminal Complaint bearing No. 478/2018 before the Court inter-alia praying that the Court direct the Accused to pay the Cheque Amount at the earliest and be penalized for an amount which is double cheque Amount. This matter is currently pending.

**ee. Criminal Complaint bearing No. 563/2018 filed by the Company (“the Complainant”) against Shahu Vajinath Bade (“the Accused”) before the Court of J.M.F.C, Hukkeri (“the Court”).**

The Company had issued an advance amount to the Accused for transportation of sugar during the harvest season of 2017-2018. However, the Complainant alleges that the accused failed to transport the sugarcane. Therefore, the Complainant requested the Accused to return the advance amount issued by the Company. On March 21, 2018, the Accused issued a cheque to the Company for the advance amount (including added interest) of ₹ 5,49,479/- (“the Cheque Amount”) which was returned by the bank on account of insufficient funds. Subsequently, the Company issued a legal notice dated April 26, 2018 to the Accused requiring the Accused to pay ₹ 5,49,479/- at the earliest. Upon receiving no response from the Accused, the Complainant filed the aforesaid Criminal Complaint bearing No. 563/2018 before the Court inter-alia praying that the Court direct the Accused to pay the Cheque Amount at the earliest and be penalized for an amount which is double cheque Amount. This matter is currently pending.

**ff. Criminal Complaint bearing No. 586 of 2015 filed by the Company (“the Complainant”) against Dattu Bhutali Pujeri (“Accused”) before the Court of the Civil Judge and JMFC Hukkeri, Hukkeri (“the Court”).**

Mr. Nikhil Umesh Katti filed a Criminal Complaint bearing No. 586 of 2015 before the Court of the Civil Judge and JMFC Hukkeri, Hukkeri against the **Accused** under Section 138 of the Negotiable Instruments Act, 1881 for the dishonour of cheque bearing number 005961 dated October 8, 2013 amounting to ₹ 5,06,323.29/- (“the said amount”), inter alia praying that the Accused be dealt with in accordance with the law and be ordered to pay the said amount as well as penalty extending to double of the said amount. The criminal case is currently pending.

**gg. Private Complaint bearing no. 70 of 2016 filed the Company (“Complainant”) against Suresh Basavanneppa Gajapati (“Accused”) before the Court of the Civil Judge and JMFC Hukkeri, Hukkeri (“the Court”).**

The Company had issued an advance amount to the Accused for transportation of sugar during the harvest season of 2009-2010. However, the Complainant alleges that the accused failed to transport the sugarcane. Therefore, the Complainant requested the Accused to return the advance amount issued by the Company. On



May 16, 2016, the Accused issued a cheque to the Company for the advance amount (including added interest) of ₹ 1,23,368/- (“the Cheque Amount”) which was returned by the bank on account of insufficient funds. Subsequently, the Company issued a legal notice dated June 14, 2016 to the Accused requiring the Accused to pay ₹ 1,23,368/- at the earliest. Upon receiving no response from the Accused, the Complainant filed the aforesaid Private Complaint bearing No. 70/2016 before the Court inter-alia praying that the Court direct the Accused to pay the Cheque Amount at the earliest and be penalized for an amount which is double cheque Amount. This matter is currently pending.

**hh. Criminal Complaint bearing No. 972 of 2017 filed by the Company (“the Complainant”) against Jyoti Kiran Patil (“Accused”) before the Court of the Civil Judge and JMFC Hukkeri, Hukkeri (“the Court”).**

The Company had issued an advance amount to the Accused for transportation of sugar during the harvest season of 2014-2015. However, the Complainant alleges that the accused failed to transport the sugarcane. Therefore, the Complainant requested the Accused to return the advance amount issued by the Company. On February 03, 2017, the Accused issued a cheque to the Company for the advance amount (including added interest) of ₹ 6,85,452/- (“the Cheque Amount”) which was returned by the bank on account of insufficient funds. Subsequently, the Company issued a legal notice dated May 11, 2017 to the Accused requiring the Accused to pay ₹ 6,85,452/- at the earliest. Upon receiving no response from the Accused, the Complainant filed the aforesaid Criminal Complaint bearing No. 972/2017 before the Court inter-alia praying that the Court direct the Accused to pay the Cheque Amount at the earliest and be penalized for an amount which is double cheque Amount. This matter is currently pending.

**ii. Criminal Complaint bearing No. 973 of 2017 filed by the Company (“the Complainant”) against Iragouda Kalagouda Patil (“Accused”) before the Court of the Civil Judge and JMFC Hukkeri, Hukkeri (“the Court”).**

The Company had issued an advance amount to the Accused for transportation of sugar during the harvest season of 2014-2015. However, the Complainant alleges that the accused failed to transport the sugarcane. Therefore, the Complainant requested the Accused to return the advance amount issued by the Company. On February 03, 2017, the Accused issued a cheque to the Company for the advance amount (including added interest) of ₹ 4,16,701/- (“the Cheque Amount”) which was returned by the bank on account of insufficient funds. Subsequently, the Company issued a legal notice dated May 11, 2017 to the Accused requiring the Accused to pay ₹ 4,16,701/- at the earliest. Upon receiving no response from the Accused, the Complainant filed the aforesaid Criminal Complaint bearing No. 973/2017 before the Court inter-alia praying that the Court direct the Accused to pay the Cheque Amount at the earliest and be penalized for an amount which is double cheque Amount. This matter is currently pending.

**jj. Criminal Complaint bearing No. 974 of 2017 filed by the Company (“the Complainant”) against Mangala Kalagouda Patil (“Accused”) before the Court of the Civil Judge and JMFC Hukkeri, Hukkeri (“the Court”).**

The Company had issued an advance amount to the Accused for transportation of sugar during the harvest season of 2014-2015. However, the Complainant alleges that the accused failed to transport the sugarcane. Therefore, the Complainant requested the Accused to return the advance amount issued by the Company. On February 03, 2017, the Accused issued a cheque to the Company for the advance amount (including added interest) of ₹ 11,51,378/- (“the Cheque Amount”) which was returned by the bank on account of insufficient funds. Subsequently, the Company issued a legal notice dated May 11, 2017 to the Accused requiring the Accused to pay ₹ 11,51,378/- at the earliest. Upon receiving no response from the Accused, the Complainant filed the aforesaid Criminal Complaint bearing No. 974/2017 before the Court inter-alia praying that the Court direct the Accused to pay the Cheque Amount at the earliest and be penalized for an amount which is double cheque Amount. This matter is currently pending.

**kk. Criminal Complaint bearing No. 1334 of 2017 filed by the Company (“the Complainant”) against Pandit Sukhadev Madar (“Accused”) before the Court of the Civil Judge and JMFC Hukkeri, Hukkeri (“the Court”).**

The Company had issued an advance amount to the Accused for transportation of sugar during the harvest season of 2014-2015. However, the Complainant alleges that the accused failed to transport the sugarcane. Therefore, the Complainant requested the Accused to return the advance amount issued by the Company. On

April 12, 2016, the Accused issued a cheque to the Company for the advance amount (including added interest) of ₹ 4,36,119/- (“the Cheque Amount”) which was returned by the bank on account of insufficient funds. Subsequently, the Company issued a legal notice dated April 25, 2016 to the Accused requiring the Accused to pay ₹ 4,36,119/- at the earliest. Upon receiving no response from the Accused, the Complainant filed the aforesaid Criminal Complaint bearing No. 1334 /2017 before the Court inter-alia praying that the Court direct the Accused to pay the Cheque Amount at the earliest and be penalized for an amount which is double cheque Amount. This matter is currently pending.

**ll. Criminal Complaint bearing No. 1335 of 2017 filed by the Company (“the Complainant”) against Dhareppa Mahadev Loni (“Accused”) before the Court of the Civil Judge and JMFC Hukkeri, Hukkeri (“the Court”).**

The Company had issued an advance amount to the Accused for transportation of sugar during the harvest season of 2014-2015. However, the Complainant alleges that the accused failed to transport the sugarcane. Therefore, the Complainant requested the Accused to return the advance amount issued by the Company. On April 12, 2016, the Accused issued a cheque to the Company for the advance amount (including added interest) of ₹ 2,77,898/- (“the Cheque Amount”) which was returned by the bank on account of insufficient funds. Subsequently, the Company issued a legal notice dated April 25, 2016 to the Accused requiring the Accused to pay ₹ 2,77,898/- at the earliest. Upon receiving no response from the Accused, the Complainant filed the aforesaid Criminal Complaint bearing No. 1335/2017 before the Court inter-alia praying that the Court direct the Accused to pay the Cheque Amount at the earliest and be penalized for an amount which is double cheque Amount. This matter is currently pending.

**mm. Criminal Complaint bearing No. 1336 of 2017 filed by the Company (“the Complainant”) against Laxman Appasab Patil (“Accused”) before the Court of the Civil Judge and JMFC Hukkeri, Hukkeri (“the Court”).**

The Company had issued an advance amount to the Accused for transportation of sugar during the harvest season of 2009-2010. However, the Complainant alleges that the accused failed to transport the sugarcane. Therefore, the Complainant requested the Accused to return the advance amount issued by the Company. On April 21, 2016, the Accused issued a cheque to the Company for the advance amount (including added interest) of ₹ 1,32,522/- (“the Cheque Amount”) which was returned by the bank on account of insufficient funds. Subsequently, the Company issued a legal notice dated May 05, 2016 to the Accused requiring the Accused to pay ₹ 1,32,522/- at the earliest. Upon receiving no response from the Accused, the Complainant filed the aforesaid Criminal Complaint bearing No. 1336/2017 before the Court inter-alia praying that the Court direct the Accused to pay the Cheque Amount at the earliest and be penalized for an amount which is double cheque Amount. This matter is currently pending.

**2. Litigation Involving Actions by Statutory/Regulatory Authorities**

**a. Ordinary Petition bearing No. 62 of 2016 filed by the Company against Bangalore Electricity Supply Company Limited and Others (“the Respondents”) before the Karnataka Electricity Regulatory Commission (“KERC”)**

The Company filed a Petition bearing No. 62/2016 before the KERK inter-alia praying for determination of the tariff for its Bagasse based co-generation power plants and for a direction to the Electric Supply Companies (ESCOMs) for executing individual Power Purchase Agreements (PPA) in their favour. Subsequently, KERK passed an Order dated December 05, 2016 inter-alia fixing an interim tariff at ₹ 3.47 per unit. Subsequently, the Respondents filed a Review Petition dated July 10, 2017 before KERK inter-alia requesting for determination of the tariff payable for the supply of power. Thereafter, the Company filed its objections under the Limitation Act, 1963 on the aforesaid Review Petition dated July 10, 2017 which was rejected by the Court vide and Order on October 24, 2017 further directing the Respondents to file their objections. This matter is currently pending.

**3. Litigation involving Tax Liabilities**

**(i) Direct Tax Liabilities**

NIL

(ii) **Indirect Taxes Liabilities**

Sr. No.	Type of Direct Tax	No. of Cases	Amount in dispute/ demanded (in ₹)
1.	Central Excise	4	8,73,44,965/-
2.	Custom Duty	2	1,77,79,527.26/-
<b>Total</b>		6	10,51,24,492.26/-

**a. Appeal dated November 21, 2011 filed by the Company before the Customs, Excise and Service Tax Appellate Tribunal, South Zonal Bench (“CESTAT”) by the Company.**

The Assistant Commissioner of Central Excise, Belgaum Division had issued a Show Cause Notice dated June 19, 2008 bearing No. 39/2008 (“SCN”) to the Company inter alia requiring the Company to show cause as to why (i) Cenvat credit of ₹ 3.35 lakhs (₹ 3,35,404) during the period from 2004-2005 to 2007-2008 should not be recovered from our Company along with interest thereon; (ii) the amount of ₹ 1.68 lakhs (₹ 1,67,522) which has been reversed to our Company should not be appropriated; (iii) interest at appropriate rate under Rule 14 of the Cenvat Credit Rules, 2004 should not be appropriated; and (iv) Penalty under Rule 15(1) of the Cenvat Credit Rules, 2004 should not be imposed on our Company for these alleged violations. The Company filed its reply vide letter dated August 13, 2008 inter alia requesting the Assistant Commissioner to vacate the SCN and drop the proceedings and refund to the Company an amount of ₹ 1,70,183/- being the amount reversed by the Company in excess. Thereafter, vide order dated January 30, 2009, the Assistant Commissioner inter- alia (i) confirmed demand of ₹ 3,35,404/-; (ii) appropriated ₹ 1,70,183/- reversed vide entry 27 dated July 27, 2007 in the Cenvat account cited supra, towards the confirmed demand as above; (iii) appropriated ₹ 1,65,221/- from ₹ 3,20,814/- paid vide GAR-7 No.01/2008-09 dated May 01, 2008 towards the demand as above; (iv) sanctioned refund of ₹ 1,55,593/- which was reversed in excess and allowed the Company to take credit in their Cenvat Account after deduction towards interest demand; (v) demanded interest under Section 11AB of Central Excise Act, 1944; (vi) appropriated an amount of ₹ 60,306/- towards demand interest and (vi) dropped the proceedings with regard to penalty proposed in the SCN. Subsequently, the Company filed an Appeal dated November 21, 2011 before the CESTAT. This matter is currently pending.

**b. Appeal dated filed by the Company before the Customs, Excise And Service Tax Appellate Tribunal, Mumbai (“CESTAT”)**

The Commissioner of Customs, Pune had issued a Show Cause Notice (“SCN”) bearing no VIII/COS/PPP/VSL/04/2013 dated July 17, 2013 requiring the Company to inter alia show cause as to why (i) The benefit of the exemption under Sr. No. 123 of the Notification No. 12/2012-Cus., dated March 17, 2012 (“**Exemption Notice**”) should not be denied to the goods imported under the said Bill of Entry No. 108/JGD/12-13 dated November 30, 2012 (“**Bill of Entry**”), filed by the Company with Ratnagiri Customs; (ii) the Bill of Entry should not be re-assessed to appropriate customs duty by reclassifying the goods imported therein as “Bituminous Coal”; (iii) Subsequent to such re-assessment, the differential duty amounting to ₹ 1,39,37,096/- (Rupees One Crore Thirty Nine Lakhs Thirty Seven Thousand and Ninety-Six only) should not be demanded and recovered from the Company along with interest thereon; and (iv) Penalty under the provisions of Section 112 (a) and Section 114A of the Customs Act, 1962 should not be imposed on the Company for these alleged violations. Subsequently, vide Order-In-Original dated January 7, 2014 passed by the Commissioner of Customs, Pune, it was inter alia held that the (i) benefit of the exemption under the Exemption Notice be denied to the goods imported under the Bill of Entry; (ii) the Bill of Entry be re-assessed; (iii) Subsequently to such re-assessment, the differential duty amounting to ₹ 1,39,37,096.26/- (Rupees One Crore Thirty Nine Lakhs Thirty Seven Thousand and Ninety-Six and Twenty-Six Paise only) be demanded and recovered from the Company along with interest thereon; and (v) Penalty of ₹ 15,00,000/- (Rupees Fifteen Lakhs only) be imposed on the Company. Thereafter, the Company filed its appeal before the CESTAT for challenging the Order-In-Original dated January 7, 2014. The matter is currently pending before CESTAT.

**c. Appeal bearing No. E/20219/2016-DB dated February 25, 2016 filed by the Company against the Commissioner of Central Excise, Customs and Service Tax, Belgaum before the Commissioner (Appeals), Customs, Excise & Service Tax Appellate Tribunal**

Vide a Show Cause Notices dated August 13, 2013, March 15, 2014, December 26, 2014 and December 02, 2015 (“SCN”) issued by the Commissioner of Central Excise, Customs and Service Tax, Belgaum, the Company has been *inter-alia* directed to show cause as to why (i) The amount of ₹ 2,36,36,992/- equal to 6% of the amount of ₹ 39,39,49,874/- being the value of electricity sold to outside power distribution companies

during the period from August-2012 to March 2013 should not be demanded from the Company (ii) the amount of ₹ 93,73,567/- equal to 60% of the amount of Rs 15,62,26,117/- being the value of electricity sold to outside to power distribution companies during the period from April 2013 to November 2013 should not be demanded and recovered from the Company (iii) the amount of ₹ 2,01,59,813/- equal to 60% of the amount of ₹ 35,59,96,882/- being the value of electricity sold to outside to power distribution companies during the period from December 2013 to October 2014 should not be demanded and recovered from the Company; and (iv) the amount of ₹ 1,05,48,860/- , equal to 6% of the amount of ₹ 77,58,14,334/- being the value of Electricity sold to outside power distribution companies during the period from November, 2014 to February, 2015, should not be demanded and recovered from the Company as Rule 14(1) of CENVAT Credit Rules, 2004 read with section 11A(1)(a) of the Central Excise Act,1944.Vide an Order in Original dated December 30, 2017 (“**Impugned OIO**”) the Commissioner dropped the proceedings initiated against the Company under the aforesaid Show Cause Notices, demanding the amount of ₹ 6,32,19,232/- on the value of electricity of ₹ 1,08,19,87,202/- sold to power distribution companies. Further, as per the aforesaid Impugned OIO the provisions of Rule 6 of the CENVAT Credit Rules, 2004 were applicable for the clearance of electricity (non-excisable goods) for a consideration by the Company. Aggrieved by the Impugned OIO, the Company preferred an appeal dated February 25, 2016 before Commissioner (Appeals), Customs, Excise & Service Tax Appellate Tribunal inter-alia praying to set aside Impugned OIO and allow the appeal. The matter is currently pending.

**d. Appeal bearing dated September 29, 2018 filed by the Company against the Commissioner (Appeals) Central Tax, Belagavi before the Commissioner (Appeals), Customs, Excise & Service Tax Appellate Tribunal, Bangalore.**

Vide a Show Cause Notice dated January 24, 2018 (“**SCN**”) issued by the Joint Commissioner of Central Excise, Customs and Service Tax, Belgaum, the Company has been *inter-alia* directed to show cause as to why the amount of ₹ 93,23,882/- equal to 6% on the amount of ₹ 15,53,98,028/- being the value of Electricity sold to outside agencies and to power distribution companies during the period from January 2016 to March 2016 should not be demanded and recovered from the Company under Rule 14 of Cenvat Credit Rules, 2004 read with Section 11A(1)(a) of the Central Excise Act, 1944. The Company filed its reply to the aforesaid SCN on March 19, 2018.Vide an Order in Original dated April 05, 2018 (“**Impugned OIO**”) the Commissioner confirmed the recovery of ₹ 93,23,882/- from the Company and further imposed a penalty of ₹ 9,32,388/- under Rule 15 of Cenvat Credit Rules, 2004 read with Section 11A(1)(a) of the Central Excise Act, 1944.Aggrieved by the Impugned OIO, the Company preferred an appeal dated May 05, 2018 before Commissioner (Appeals), Central GST and Central Excise, Belgaum inter-alia praying to set aside Impugned OIO and allow the appeal. The matter is currently pending. Vide an Order in Appeal dated August 09, 2018 (“**Impugned AIO**”) the Commissioner (Appeals) Central Tax, Belagavi upheld the Impugned Order and dismissed the Aforesaid Appeal dated May 05, 2018. Aggrieved by the Impugned AIO, the Company preferred an appeal dated September 29, 2018 before the Customs, Excise, Service Tax Appellate Tribunal, South Zonal Bench, and Bangalore inter-alia praying to set aside Impugned OIA and allow the appeal. The matter is currently pending.

**e. Appeal bearing dated April 02, 2018 filed by the Company against the Commissioner (Appeals) Central Tax, Belagavi before the Commissioner (Appeals), Customs, Excise & Service Tax Appellate Tribunal, Bangalore.**

Vide a Show Cause Notice dated March 29, 2016 (“**SCN**”) issued by the Commissioner of Central Excise, Customs and Service Tax, Belgaum, the Company has been *inter-alia* directed to show cause as to why the amount of ₹ 1,44,66,447/- equal to 6% on the amount of ₹ 24,11,07,442/- being the value of Electricity sold to outside agencies and to power distribution companies during the period from March 2015 to December 2015 should not be demanded and recovered from the Company under Rule 14 of Cenvat Credit Rules, 2004 read with Section 11A(1)(a) of the Central Excise Act, 1944. The Company filed its reply to the aforesaid SCN on June 03, 2016.

Vide an Order in Original dated February 27, 2017 (“**Impugned OIO**”) the Joint Commissioner confirmed the recovery of ₹ 1,44,66,447/- from the Company and further imposed a penalty of ₹ 14,46,645/- under Rule 15 of Cenvat Credit Rules, 2004 read with Section 11A(1)(a) of the Central Excise Act, 1944.Aggrieved by the Impugned OIO, the Company preferred an appeal dated April 03, 2017 before Commissioner (Appeals), Central GST and Central Excise, Belgaum inter-alia praying to set aside Impugned OIO and allow the appeal. The matter is currently pending. Vide an Order in Appeal dated December 15, 2017 (“**Impugned AIO**”) the Commissioner (Appeals) Central Tax, Belagavi upheld the Impugned Order and dismissed the Aforesaid



Appeal dated April 03, 2017. Aggrieved by the Impugned AIO, the Company preferred an appeal dated April 02, 2018 before the Customs, Excise, Service Tax Appellate Tribunal, South Zonal Bench, Bangalore inter-alia praying to set aside Impugned OIA and allow the appeal. The matter is currently pending.

**f. Appeal bearing dated April 11, 2017 filed by the Company against the Commissioner of Customs (Appeals), Bangalore before the Commissioner (Appeals), Customs, Excise & Service Tax Appellate Tribunal, Bangalore.**

Vide a Show Cause Notice dated August 08, 2013 (“SCN”) issued by the Additional Commissioner of Customs, Mangalore, the Company has been *inter-alia* directed to show cause as to why the subject goods i.e., 10000 MT of coal imported per vessel MV tianjin, venture, through New Mangalore port vide Bill of Entry No. 8051255 dated September 29, 2012 should not be classified as Bituminous Coal as defined under the Customs Tariff Act, 1975 and the differential duty of ₹ 38,42,431/- arising on account of change in rates of duty owing to its reclassification of subject goods should not be demanded and recovered from the Company. The Company filed its reply to the aforesaid SCN on October 01, 2013. Vide an Order in Original dated June 30, 2014 (“**Impugned OIO**”) the Additional Commissioner of Customs, Mangalore (i) confirmed the demand duty of ₹ 38,42,431/-; (ii) demanded interest under Section 28 AA of the Customs Act, 1975; (iii) held 10,000 MT of imported coal liable for confiscation as per Section 111 (m) of the Customs Act, 1975 and (iv) imposed a penalty of ₹ 5,00,000/- under Section 112 (a) of the Customs Act, 1975 from the Company. Aggrieved by the Impugned OIO, the Company preferred an appeal dated August 04, 2016 before Commissioner of Customs, Bangalore inter-alia praying to set aside Impugned OIO and allow the appeal. The matter is currently pending. Vide an Order in Appeal dated September 20, 2016 (“**Impugned AIO**”) the Commissioner of Customs (Appeals), Bangalore upheld the Impugned Order and dismissed the Aforesaid Appeal dated August 04, 2016. Aggrieved by the Impugned AIO, the Company preferred an appeal dated April 11, 2017 before the Customs, Excise, Service Tax Appellate Tribunal, Bangalore inter-alia praying to set aside Impugned OIA and allow the appeal. The matter is currently pending.

**4. Other Pending Litigations**

**a. Regular First Appeal 1450 of 2015 filed by the Company (“Petitioner”) against (i) John Distilleries and (ii) Venkateshwara Distilleries (“Defendants”) before the Hon’ble High Court of Karnataka, Bangalore.**

Ordinary Suit dated bearing no. 4788 of 2009 was filed by the Plaintiff before the XVIII Additional City Civil Judge Court against the Defendants for permanent injunction against debarring the Defendants from use of the label "Our Choice" inter alia praying for a decree of permanent injunction and other reliefs against the Defendants. Aggrieved by the judgment and decree dated July 28, 2015, the Company filed a Regular First Appeal bearing no. 1450 of 2015 before the High Court of Karnataka, Bangalore inter-alia praying to the Court to call for records on file of XVIII Additional City Civil Judge Court in Original Suit no. 4788 of 2015 and setting aside the aforesaid judgment and decree in the interest of justice. This matter is currently pending before the Court.

**b. Writ Petition dated January 21, 2019 bearing No. 104162-163 of 2019 filed by the Company against The Union of India (“the Respondent No. 1”), the Superintendent of Central Excise, Belgaum Audit Circle (“the Respondent No. 2”) and the Superintendent of Central GST Range I and II, Nippani (“the Respondent No. 3”) before The High Court of Karnataka (“The Court”).**

The Company under Section 140 of the Goods and Service Tax Act, 2017 (“The Act”) claimed a total transactional credit of ₹ 9,09,72,058/- out of which ₹ 2,52,79,965 (“the Amount”) is the sugar cess. On October 13, 2017, the Respondent No. 1 directed the Company to reverse the aforesaid amount on the grounds of its ineligibility to be claimed as credit and the same was directed by the Respondent 2. On April 4, 2018 Respondent 3 notified the Company that the Respondents would recover the Amount under Section 79 of the Act to which the Company filed an objection inter-alia stating that action under Section 79 of the Act cannot be invoked without adhering to Section 73 and 74 of the Act. Consequently, the Company filed the aforesaid Writ Petition dated January 21, 2019 inter-alia praying that the Court grants a Writ of Certiorari quashing the notification dated April 04, 2018 issued by the Respondent 3 as it is passed in violation of the principles of natural justice. The matter is currently pending.

- c. **Special Leave Petition (CRL.) bearing no. 14016-14018 of 2017 filed by the Company against The Union of India and others (“the Respondents”) before the Hon’ble Supreme Court of India (“the Hon’ble Court”).**

The Company had filed Writ Petition No. 83223 of 2013 and Writ Petition No.19874 of 2013 before the Hon’ble High Court of Karnataka, Dharwad Bench (“**the Hon’ble High Court**”) challenging the Orders dated May 23, 2013, September 12, 2013, September 18, 2013, July 27, 2012 and November 26, 2012 (“**the Orders**”) under which Orders directions were issued by recovery of levy sugar from the Company for the seasons 2005-2009 and seizure of sugar of the Company on September 26, 2013 by the Respondents. In the said Writ Petitions, the Company had stated that the Respondents issued a Levy Sugar Supply (Control) Order, 1979 (‘the 1979 Order’) under which the Central Government had the power to direct a sugar manufacturer to supply a certain percentage of sugar produced by it at a price determined under Section 3 (3-C) of the Essential Commodities Act, 1955. Further, the Respondents issued a notification dated November 30, 2010 bearing no. F.No.5-5(Legal - 21)/ 2009-SC-II (“**the Notification**”) clarifying that the sugar mills will be allowed to sell equivalent quantity of their uplifted levy sugar even after a lapse of three months from the date of allotment in the open market and that the obligation with respect to levy sugar will remain unchanged. Subsequently, the Company filed the above Writ Petitions in challenging the Orders and the seizure of sugar inter-alia on the grounds that on failure of the government to issue levy quote orders, the right to issue the same lapses and cannot be enforced for the subsequent years. Vide Order dated December 18, 2013, the Hon’ble High Court inter-alia held that authorized corporation would liquidate the accumulated monthly carry liabilities within 3 months beyond which the same would not continue and there would not be any carry forward of past liabilities and the levy liability would start with clean slate every year. and dismissed the aforesaid Orders. Upon being aggrieved by the aforesaid Order dated December 18, 2013, the Respondents filed Writ Appeals bearing Nos.100474 of 2015 and 100018–100019 (GM-RES) (“**Writ Appeals**”) before the Hon’ble High Court. Vide Order dated January 03, 2017, the High Court partly (i) allowed the Writ Appeals, (ii) set aside the Order dated December 18, 2013 passed in Writ Petition No. 83223 of 2013 and (iii) directed the Respondents to re-calculate the amount of levy sugar that the Petitioner is obliged to deposit with the Government in discharge of its obligations for sugar seasons 2005 to 2008 and 2009 -10. Consequently, the Company filed the above Special Leave Petition before the Hon’ble Court against the Respondents challenging the aforesaid Order dated January 03, 2017 passed by the Hon’ble High Court. This matter is currently pending.

## LITIGATION INVOLVING OUR DIRECTORS

### A. LITIGATION AGAINST OUR DIRECTORS

#### 1. Criminal matters

- a. **Criminal Writ Petition 3895 of 2016 filed by Kundlik Gopal Bhegade (“the Petitioner”) against the Directors of National Heavy Engineering Co. Op. Ltd. (our Director/Promoter, Mr. Nikhil Katti is also a director) (“NHECOL”) before the Hon’ble High Court of Judicature at Bombay (“the Court”)**

The Petitioner, who is the president of NHECOL had lodged a complaint under Sections 406, 420 and 34 of Indian Penal Code, 1860 against the directors of NHECOL, including Mr. Nikhil Katti, inter-alia alleging that NHECOL had failed to deposit an amount of ₹ 67,44,794/- which was deducted from the salaries of workers from the period from March 2013 to March 2015. The Judicial Magistrate of the First Class (“**Magistrate**”) vide an order dated May 27, 2016 (“**JMFC Order**”) passed an order under Section 156(3) of Criminal Procedure Code, 1973. Aggrieved by the JMFC Order, Mr. Nikhil Katti filed a Criminal Revision Application bearing no. 291/2016 against the JMFC Order before the Hon’ble Sessions Judge, Pune (“**Hon’ble Sessions Judge**”) inter-alia stating that the Assistant Register of Co-Operative Department Vadgaon Maval, Pune has already taken the cognizance of the alleged act and therefore the Magistrate should not have directed the police to investigate the matter. The Hon’ble Sessions Judge vide an order dated October 17, 2016 (“**Revision Order**”) allowed the revision petition and set aside the impugned JMFC Order. Aggrieved by the Revision Order the Petitioner, filed Criminal Writ Petition bearing no. 3895 of 2016 before the Hon’ble High Court of Judicature at Bombay (“**Hon’ble Court**”) inter-alia praying for writ of certiorari for quashing and setting aside the Revision Order. The matter is pending before the Hon’ble Court.

#### 2. Litigation Involving Actions by Statutory/Regulatory Authorities

NIL



**3. Litigation involving Tax Liabilities**

**(i) Direct Tax Liabilities**

NIL

**(ii) Indirect Taxes Liabilities**

NIL

**4. Other Pending Litigations**

NIL

**B. LITIGATION FILED BY OUR DIRECTORS**

**1. Litigation Involving Criminal matters**

NIL

**2. Litigation Involving Actions by Statutory/Regulatory Authorities**

NIL

**3. Litigation involving Tax Liabilities**

**(i) Direct Tax Liabilities**

NIL

**(ii) Indirect Taxes Liabilities**

NIL

**4. Other Pending Litigations**

NIL

**LITIGATION INVOLVING OUR PROMOTERS**

**A. LITIGATION AGAINST OUR PROMOTERS**

**1. Litigation Involving Criminal matters**

For details regarding the litigation filed against our Promoters, please refer to the section titled 'Litigations involving our Directors' of this chapter beginning on page no. 295 of this Red Herring Prospectus.

**2. Litigation Involving Actions by Statutory/Regulatory Authorities**

NIL

**3. Litigation involving Tax Liabilities**

**(i) Direct Tax Liabilities**

NIL

**(ii) Indirect Taxes Liabilities**

NIL

**4. Other Pending Litigations**

NIL

**B. LITIGATION FILED BY OUR PROMOTERS**

**1. Litigation Involving Criminal matters**

NIL

**2. Litigation Involving Actions by Statutory/Regulatory Authorities**

NIL

**3. Litigation involving Tax Liabilities**

**(i) Direct Tax Liabilities**

NIL

**(ii) Indirect Taxes Liabilities**

NIL

**4. Other Pending Litigations**

NIL

**LITIGATION INVOLVING OUR GROUP COMPANIES**

**A. LITIGATION AGAINST OUR GROUP COMPANIES**

**1. Litigation involving Criminal matters**

NIL

**2. Litigation Involving Actions by Statutory/Regulatory Authorities**

NIL

**3. Litigation involving Tax Liabilities**

**(i) Direct Tax Liabilities**

NIL

**(ii) Indirect Taxes Liabilities**

NIL

**4. Other Pending Litigations**

NIL

---

**B. LITIGATION FILED BY OUR GROUP COMPANIES****1. Criminal matters**

NIL

**2. Litigation Involving Actions by Statutory/Regulatory Authorities**

NIL

**3. Litigation involving Tax Liabilities****(i) Direct Tax Liabilities**

NIL

**(ii) Indirect Taxes Liabilities**

NIL

**4. Other Pending Litigations**

NIL

**There are no litigations or legal actions, pending or taken, by any Ministry or Department of the Government or a statutory authority against our Promoters during the last 5 (five) years.**

There are no litigations or legal actions, pending or taken, by any Ministry or Department of the Government or a statutory authority against our Promoters during the last 5 (five) years.

**Pending proceedings initiated against our Company for economic offences.**

There are no pending proceedings initiated against our Company for economic offences.

**Inquiries, investigations etc. instituted under the Companies Act, 2013 or any previous companies enactment in the last 5 (five) years against our Company.**

There are no inquiries, investigations etc. instituted under the Companies Act or any previous companies enactment in the last 5 (five) years against our Company except as stated below:

Our Company was involved in proceedings before the NCLT and also before SEBI for alleged violation of public issue requirements by the Company under Companies Act, 1956. The Company undertook certain steps to give investors an option to surrender the securities issued by the Company and obtain refunds of the amounts invested. All the formalities pertaining to the above have been completed and the relevant confirmations and certificate of the same have been submitted to SEBI as per procedure. For further information, see “Capital Structure – Notes to Capital Structure” on page no. 70 and Risk Factor No. 1 on page no. 17 of this Red Herring Prospectus, respectively.

**Material Fraud against our Company in the last 5 (five) years**

There has been no material fraud committed against our Company in the last 5 (five) years.

**Fines imposed or compounding of offences for default**

There are no fines imposed or compounding of offences done in the last 5 (five) years immediately preceding the year of the Draft Prospectus for the Company for default or outstanding defaults.

---

### **Non-Payment of Statutory Dues**

There have been no defaults or outstanding defaults in the payment of statutory dues payable by the Company as of the date of the last audited financial statements of the Company.

### **Amounts owed to small scale undertakings and other creditors**

In terms of our Materiality Policy adopted by the Board vide Resolution dated December 18, 2017; there are no outstanding amounts above 1% of the total revenue as per audited financial statements of March 31, 2019 due to any creditors by our Company. The company is in process of identifying its MSME creditors for which the company has sent the letter to its creditors. As on date of filing of this Red Herring Prospectus, no creditor has responded to the same and hence disclosure, if any, in relation to amount unpaid as at the year-end together with interest payable as required under the said MSME Act has not been furnished. As on March 31, 2019, an amount aggregating to ₹ 11,271.89 lakhs was outstanding and due to 15,255 creditors by our Company (includes outstanding for Cane payables and payables to H & T Contractors). Details in relation to the amount owed by our Company to material creditors, small scale undertakings and other creditors as on March 31, 2019 are also available on [www.vsil.co.in](http://www.vsil.co.in).

*It is clarified that any other information provided on the website of our Company is not a part of this Red Herring Prospectus and should not be deemed to be incorporated by reference. Anyone placing reliance on any other source of information, including our Company's website, would be doing so at its own risk.*

### **Material developments occurring after last balance sheet date**

Except as disclosed elsewhere in this Red Herring Prospectus, there have been no material developments that have occurred after the Last Balance Sheet Date.

## GOVERNMENT & OTHER KEY APPROVALS

*Our Company has received the necessary licenses, permissions and approvals from the Central and State Governments and other government agencies/regulatory authorities/certification bodies required to undertake the Offer or continue our business activities. In view of the approvals listed below, we can undertake the Offer and our current business activities and no further major approvals from any governmental/regulatory authority or any other entity are required to be undertaken, in respect of the Offer or to continue our business activities. It must, however, be distinctly understood that in granting the above approvals, the Government of India and other authorities do not take any responsibility for the financial soundness of our Company or for the correctness of any of the statements or any commitments made or opinions expressed in this behalf.*

*The main objects clause of the Memorandum of Association of our Company and the objects incidental, enable our Company to carry out its activities.*

### Approvals for the Offer

1. The Board of Directors have, pursuant to Section 62(1)(c) of the Companies Act, 2013, by a resolution passed at its meeting held on November 20, 2017 authorized the Offer, subject to the approval of the shareholders and such other authorities as may be necessary.
2. The shareholders of our Company have, pursuant Section 62(1)(c) of the Companies Act, 2013, by a special resolution passed in the extra ordinary general meeting held on December 18, 2017 authorized the Offer.
3. In-principle approval dated January 12, 2018 from the BSE for listing of the Equity Shares issued by our Company pursuant to the Issue.
4. In-principle approval dated January 10, 2018 from the NSE for listing of the Equity Shares issued by our Company pursuant to the Issue.

### Approvals pertaining to Incorporation, name and constitution of our Company

1. Certificate of Incorporation dated May 02, 1995 issued by the Registrar of Companies, Bangalore, Karnataka in the name of “Vishwanath Sugars Limited”.
2. Fresh Certificate of Incorporation dated December 28, 2010 issued by the Registrar of Companies, Bangalore, Karnataka pursuant to change of name of the Company from “Vishwanath Sugars Limited” to “Vishwanath Sugar and Steel Industries Limited”.
3. Fresh Certificate of Incorporation dated November 29, 2012 issued by the Registrar of Companies, Bangalore, Karnataka pursuant to change of name from “Vishwanath Sugar and Steel Industries Limited” to “Vishwaraj Sugar Industries Limited”
4. Certificate of Commencement of Business dated December 21, 1999 issued by the Registrar of Companies, Bangalore, Karnataka.
5. The Corporate Identification Number (CIN) of our Company is U85110KA1995PLC017730.

### I. BUSINESS RELATED APPROVALS

Sr. No.	Description	Authority	Registration Number	Date of Certificate	Date of Expiry
1.	License under Food Safety and Standards Act.	Food Safety and Standards Authority of India	10015043001290	August, 03, 2015	August 02, 2020
2.	Certificate of Importer-Exporter Code (IEC)	Foreign Trade Development Officer, Bengaluru	0703008790	July 12, 2013	Valid until cancelled
3.	Permission to draw water for industrial use	Executive Engineer, KNNL GRBCC, Division 2, Hidkal Dam	WRDO/81/NIN2012	January 10, 2013	July 21, 2020

Sr. No.	Description	Authority	Registration Number	Date of Certificate	Date of Expiry
4.	Final Allotment of Plant Code No. 62101 and Short Name "Bellad Bagewadi"	Chief Director(Sugar), Directorate of Sugar, Department of Food and Public Distribution, Ministry of Consumer Affairs, Food & Public Distribution	6-1(8)/2009-Stat-II/276-281	January 04, 2010	Valid until cancelled
5.	NoC for height clearance of chimney* <i>The Company however has misplaced the copy of this approval</i>	Assistant General Manager, Airports Authority of India	AAI/420012/839/2005 -ARI(NOC)	December 02, 2005	-
6.	Certificate for use of Boiler KTK 2405 with Maximum continuous evaporation of 10 TPH.	Deputy Director of Boilers, Belagavi Division, Belagavi	Certificate No: 190 GSC No.: IS0990000070610	March 11, 2019	Valid until March 09, 2020
7.	Certificate for use of Boiler KTK 3459 with maximum continuous evaporation of 14 TPH.	Deputy Director of Boilers, Belagavi Division, Belagavi	Certificate No: 192 GSC No. IS0990000070942	March 20, 2019	Valid until March 18, 2020
8.	Commissioning approval of 14.4 kms long 110 KV Single Circuit Line on Double Circuit Tower and one 110 KV Terminal Bay	Chief Electrical Inspector to Government of Karnataka	CEIG/DCEI/EI(T)/DE 11/16098-101/05-06	October 11, 2005	Valid until cancelled
9.	Commissioning approval of Switch Yard	Chief Electrical Inspector to Government of Karnataka	CEIG/DCEI/EI(T)/DE 11/16089-92/05-06	October 11, 2005	Valid until cancelled
10.	Synchronisation Approval of 14 MW gross capacity with an exportable capacity of 7.8 Mw from Co-Generation Power Project	Deputy General Manager (Tech), Karnataka Power Transmission Corporation Limited	KPTCL/B-28/4149/2000-01	October 14, 2005	Valid until cancelled
11.	Approval for revision of evacuation scheme for 39 MW (Exportable 22.4 Mw) co-generation power plant at the factory of the Company	Chief Engineer Electrical, Karnataka Power Transmission Corporation Limited	CEE(P&C)/KCO-93/8892/F-41	April 30, 2008	Valid until cancelled
12.	Approval to commission the electrical installation of additional 22.4 MW, 11 KV Unit II Co-generation Plant along with 7500 TCD Sugar Plant and Distillery Plant	Chief Electrical Inspector to Government of Karnataka	CEIG/EI-3/31906-10/09-10	January 06, 2010	Valid until cancelled
13.	Regular Interconnection Approval for interconnecting 22.4 MW exportable an 39 MW gross Cogeneration Power	Chief Engineer (Electy), Karnataka Power Transmission Corporation Limited	CEE9TA&QC)/SEE9 Plg)/EE(Plg)/KCO-93/17412/F-41	January 28, 2010	Valid until cancelled
14.	License to store petroleum in tank/s under the Petroleum Act, 1934	Jt. Chief Controller of Explosives, Mangalore	P/SC/KA/14/3713(P23 9869)	November 24, 2017	December 31, 2020
15.	Letter of authorization under Foreign Trade (Development and	Assistant Director General of Foreign Trade	0730015953/3/12/00	November 07, 2016	November 06, 2023



Sr. No.	Description	Authority	Registration Number	Date of Certificate	Date of Expiry
	Regulation) Act, 1992.				
16.	Certificate of Verification under the Karnataka Legal Metrology Rules, 2011	Assistant Controller of Legal Metrology, Belgaum	AC21927	September 29, 2018	September 28, 2019
17.	Consent to Establish from Gram Panchayat for 5500 FCD Sugar plant and 30Mx co-generation power plant at Rs. Nos. 136, 139, 140/1, 140/2, 140/3 and 141/1 at Bellad, Bagewadi Village.	Gram Panchayat, Bellad Bagewadi	-	February 18, 2013	-
18.	Environment Clearance for expansion of Sugar Plant (5500-11000 TCD) molasses based Distillery Unit (35 KLPD to 100 KLPD), ENA Plant (20KLPD to 75KLPD) and Co-generation Power Plant (39Mw to 64 Mw) establishment of Ethanol Plant (30KLPD) and D.G sets (2x1mw) at factory premises located at Plot Nos. 136, 139/2, 140/1, 140/2, 140/3, 140/4, 140/4, 141/1, 148/3, 149/2, 149/3, 150/1, 150/2A, 150/2B, 150/2A, 151/1, 151/2C and 152.	Ministry of Environment and Forests, (I.A. Division)	J-11011/453/2009-1A II (1)	November 24, 2011	-
19.	Registration and License to run factory	Department of Factories, Boilers, Industrial Safety and Welfare, Government of Karnataka	MYBGM 2325	November 16, 2018	December 31, 2019
20.	Certificate of Registration under Food Safety Management System.  <i>Scope of the Certificate:</i> Processing (Mash Preparation, Fermentation and Filtration) of Brewed Vinegar from Spirit.	Intertek India Private Limited	Certificate Number: 0085236	December 17, 2018	December 15, 2021
21.	Combined Consent for discharge of effluents under the Water (Prevention and Control of Pollution) Act, 1974 and Air (Prevention and Control of Pollution) Act, 1981 authorizing the Company to operate the Industrial plant at Bellad-Bagewadi Village, Hukkeri	Karnataka State Pollution Control Board	Combined Consent Order No. PCB/157/HPI/2017-2018	February 20, 2018	June 30, 2021

Sr. No.	Description	Authority	Registration Number	Date of Certificate	Date of Expiry
	Taluk, Belgaum District and to discharge of effluents and emissions in respect of the (i) Trade effluent from Sugar Plant-740 KLD, (ii) Trade effluents from Distillery (Spent Wash)- 381 KLD and (iii) Co-gen Plant and IML Bottling- 206 KLD. The Consent is valid for the manufacture of (i) Whiter crystal sugar- 8500 TCD, (ii) Co, generation- 39 MW, (iii) Rectified Spirit or Ethanol- 35 KLD, (iv) IML Bottling- 5000 Boxes/day, (v) ENA- 30 KLPD, (vi) Natural Alcohol Vinegar- 75 KLPD, Liquid Carbon-di-oxide- 15 MTPD.				
22.	Consent for establishment for expansion of sugarcane crushing capacity from 5500 TCD to 11000 TCD, rectified spirit from 35 KLD to 100 KLD, Cogeneration plant of 39 MW to 64 MW, IML bottling from 2500 boxes a day to 5000boxes/ day, ENA plant from 20 KLD to 75 KLD, establishment of ethanol plant of 30 KLD and installation of 2x1250 KVA DG sets at Belladbagewadi, Hukkeri Taluk, Belgaum, District.	Karnataka State Pollution Control Board	PCB/157/HPI/2010-11/1408	February 13, 2013	Coterminous with the Environment Clearance issued by Ministry of Environment and Forests dated November 24, 2011.
23.	Permission to lift essential 21.89 MCET water annually from Ghataprabha River for Industrial purpose.	Governor of Karnataka, Under Secretary to Government, Jalasampanmula, Department (Technical-4)	JSE 32 NIN 2016 Bengaluru.	November 16, 2017	July 21, 2020
24.	Memorandum of Understanding between the Company and Government of Karnataka with an objective to ensure that adequate quantity of ENA is made available to IMFL manufactures and to ensure that alcohol mean for non-potable purposes is not misused/ diverted to potable purposes*	Government of Karnataka	-	June 27, 2019	June 26, 2020.

## II. INDUSTRIAL ENTREPRENEUR MEMORANDUM OBTAINED BY THE COMPANY

Sr. No.	Description	Authority	Registration Number	Date of Certificate	Date of Expiry
1.	Industrial Entrepreneur Memorandum for manufacture of Rectified Spirits for adding proposed capacity of 19500 KL/year to already existing capacity of 10500 KL/year making its total capacity 30000 KL/year after expansion.	Secretariat of Industrial Assistance, Ministry of Commerce and Industry	422/SIA/IMO/2011	February 07, 2011	-
2.	Industrial Entrepreneur Memorandum for manufacture of Extra Neutral Spirit for adding proposed capacity of 15000 KL/year, to already existing capacity of 6000 KL/year making its total capacity 21000 KL/year after expansion.	Secretariat of Industrial Assistance, Ministry of Commerce and Industry	422/SIA/IMO/2011	February 07, 2011	-
3.	Industrial Entrepreneur Memorandum for manufacture of Industrial Alcohol for adding proposed capacity of 45000 KL/year, to already existing capacity of 45000 KL/year making its total capacity 9000 KL/year. #	Secretariat of Industrial Assistance, Ministry of Commerce and Industry	422/SIA/IMO/2011 <sup>2</sup>	February 07, 2011	-
4.	Industrial Entrepreneur Memorandum for manufacture of Electricity for adding proposed capacity of 216000 mw/hrs to already existing capacity of 280800 mw/hrs making its total capacity 496800 mw/hrs after expansion.	Secretariat of Industrial Assistance, Ministry of Commerce and Industry	2763/SIA/IMO/2011 <sup>1</sup>	August 30, 2011	-
5.	Industrial Entrepreneur Memorandum for manufacture of White Crystalline Sugar for adding proposed capacity of 83600 tons to already existing capacity of 158400 tons making its total capacity 242000 tons after expansion.	Department for Promotion of Industry and Internal Trade, Ministry of Commerce and Industry	2765/SIA/IMO/2011	May 16, 2019	-
6.	Industrial Entrepreneur Memorandum for manufacture of Bagasse for adding proposed capacity of 228000 tons to already existing capacity of 432000 tons making its total capacity 660000 tons after expansion.	Department for Promotion of Industry and Internal Trade, Ministry of Commerce and Industry	2765/SIA/IMO/2011	May 16, 2019	-

7.	Industrial Entrepreneur Memorandum for manufacture of Molasses for adding proposed capacity of 30400 tons to already existing capacity of 57600 tons making its total capacity 88000 tons after expansion.	Department for Promotion of Industry and Internal Trade, Ministry of Commerce and Industry	2765/SIA/IMO/2011	May 16, 2019	-
8.	Industrial Entrepreneur Memorandum for manufacture of Brewed Vinegar for total capacity of 10,350 Kilo litres per annum.	Department for Promotion of Industry and Internal Trade, Ministry of Commerce and Industry	2917/SIA/IMO/2012 <sup>3</sup>	May 16, 2019	-

# The IEM dated February 07, 2011 bearing no. 422/SIA/IMO/20113 refers to proposed capacity of 45000 KL/year being added to the existing capacity of 45000 KL/year. However, the total capacity reflected on the IEM is 9000. The Company currently adheres to the total capacity of 9000 and the references made to the proposed and existing capacity of 45000 KL/year are erroneously recorded under the abovementioned IEM.

<sup>1</sup> vide letter dated December 18, 2012, the Secretariat of Industrial Assistance, Ministry of Commerce and Industry has confirmed the change in the name of the company from “Vishwanath Sugar and Steel Industries Limited” to “Vishwaraj Sugar Industries” in respect of IEM Acknowledgment No. 2763/SIA/IMO/2011 dated August 30, 2011.

<sup>2</sup> vide letter dated December 18, 2012, the Secretariat of Industrial Assistance, Ministry of Commerce and Industry has confirmed the change in the name of the company from “Vishwanath Sugar and Steel Industries Limited” to “Vishwaraj Sugar Industries” in respect of IEM Acknowledgment No. 422/SIA/IMO/2011 dated February 07, 2011.

<sup>3</sup>The IEM acknowledgement dated May 16, 2019 bearing reference no. 2197/SIA/IMO/2012 refers to total capacity of 10,350 LTPD (liters per day). However, the total capacity applied for under the application made by the Company is 10,350 KLPA (Kilo Liters Per Annum).The Company is in the process of making an application to the concerned authorities to have the reference made to the unit of measurement ‘LTPD’ rectified to reflect the correct unit of measurement ‘KLPA’.

### III. DISTILLERY RELATED APPROVALS ACQUIRED BY THE COMPANY

Sr. No.	Description	Authority	Registration Number	Date of Certificate	Date of Expiry
1.	Permission for installation of one new machine in the distillery, two service tanks of 2000 litres each and construction of shed for storage of raw materials used for aseptic packing machine	Deputy Commissioner of Excise	ECD/13/REV/Be lagavi/2016-17	December 03, 2016	-
2.	Permission for replacing one Kakambi tank out of two tanks having capacity of 7000 m tn. each and installing two new tanks of 7000 m. tn and 6000 m. tn for storage of Kakambi.	Deputy Commissioner of Excise	ECE/76/Kakambi/2011	March 21, 2012	-
3.	Permission for use of two new Kakambi tanks having 7000 MT capacity each.	Deputy Commissioner of Excise	ECE/40/Kakambi-1/2013	October 13, 2014	-
4.	Permission for following substitutions in the Distillery: a. Installation of 20mm pipe having flinch in the roof portion of fermentation b. Installation of 100mm transparent glass and light glass in the roof portion of fermentation	Deputy Commissioner of Excise	ECD/03/REV/Be lagavi/2013-14	July 22, 2014	-

	c. Installation of new pipeline connection with 250mm PVC Pipes and new pipelines for the proposed carbon dioxide plant d. Fixing of 25mm new M.S. Pipes for supply of steam to the proposed carbon dioxide plant from distillation section				
5.	Permission for installation of one automatic belt and two blending tanks of 1000 and 3000 litres each for preparation of 1800 Indian liquor boxes.	Deputy Commissioner of Excise	ECD/46/REV/2010	February 04, 2011	-
6.	Permission for installation of one automatic belt and two semi-automatic belt in the distillery	Deputy Commissioner of Excise	ECD/46/REV/2010	June 09, 2011	-
7.	Permission for installation of new 65 K.L.P.D. liquor substance production unit.	Deputy Commissioner of Excise	ECD/37/REV/Be lagavi /2011-12	September 22, 2016	-
8.	Permission for change in the name of the Distillery "M/s Vishwanath Sugar and Steel Industries Limited" into "Vishwaraj Sugar Industries Limited"	Commissioner of Excise	ECD/20/REV/2012	June 20, 2013	-
9.	Permission for constructing of: a. One another warehouse. b. Two new 550 m-3 cooling tower along with one existing 550 m-3 cooling tower. c. another 32 diameter tank along with one existing 21 meter digester tank. d. 1,00,000/- B.L. capacity liquor substance storage tank. e. 38,000/- B.L. capacity ethanol storage tank. f. 1,00,000/- B.L. capacity three neutral spirit storage tanks. g. 1,00,000/- B.L. capacity M.G. alcohol storage tank. h. installing two M. G. Alcohol storage tank of 60,000 B.L. capacities in the existing warehouse along with i. 50,000 B L. capacity liquor substance storage tank in the new warehouse j. 3 neutral spirit storage tank of 50,000 BL capacity in the new warehouse	Deputy Commissioner of Excise	ECD/37/REV/Be lagavi /2011-12	September 22, 2016	-
10.	Permission for making following changes in Indian liquor production unit: a. Installing tank no. 11 having 30000 litre capacity in place of tank no. 8. b. Installing two tanks numbered 13 &14 having 50000 litre capacity each by the side of tank	Deputy Commissioner of Excise	ECD/16/REV/Be lagavi/2013-14	April 23, 2014	-

	no. 9 and 10. c. Installing tank no. 12 of 30000 litre capacity by the side of D. M water tank. d. Reinstalling tank no.5 and tank no.8. e. Construction of Indian liquor production office in place of Tank no. 5				
11.	Permission for making following changes in primary distillery unit: a. Installing a new 850 K.V. Turbine along with existing 300 K.V b. Installing 2 additional columns (Fuel oil column and head column) along with existing 3 columns c. Installing 5 condensers along with the existing 5 d. Installing 4 re-boilers along with existing one re boiler and the necessary pipelines for the same.	Deputy Commissioner of Excise	ECD/16/REV/Be lagavi/2013-14	April 23, 2014	-
12.	Permission to export liquor for the year 2016-17	Deputy Commissioner of Excise	ECD/26/Con/2016	August 17, 2016	-
13.	Distillery License	Excise Commissioner, Karnataka, Bengaluru	EX7DVISHWA RAJES20190629 40	July 22, 2019	June 30, 2020
14.	License for the bottling of Liquor	Excise Commissioner, Karnataka, Bengaluru	EX7DVISHWA RAJES20190629 40	July 22, 2019	June 30, 2020
15.	License for possession and use of Molasses for the manufacture of Rectified Spirit viz. for manufacture of alcohol with a quota of 60,000 MT of molasses per annum	Excise Commissioner, Karnataka, Bengaluru	EX29PDVISHW ARAJSUGARM 2ES2019070240	August 6, 2019	June 30, 2020
16.	License for possession and sale of molasses by the sugar factory of the Company	Excise Commissioner, Karnataka, Bengaluru	EX29SVISHWA RAJASUGARS ES201907038	July 16, 2018	June 30, 2020

#### IV. TAX RELATED APPROVALS



Sr. No.	Description	Authority	Registration Number	Date of Certificate	Date of Expiry
1.	Permanent Account Number (PAN)	Income Tax Department	AABCV1727H	-	Valid until cancelled
2.	Tax Deduction Account Number (TAN)	Income Tax Department	BLRV03401G	April 20, 2004	Valid until cancelled
3.	Tax Payer Identification	Sales Tax Officer,	29610385979	September	Valid until



Sr. No.	Description	Authority	Registration Number	Date of Certificate	Date of Expiry
	Number (TIN) under Karnataka Value Added Tax Act, 2003	Sankeshwar		22, 2008	cancelled
4.	Certificate certifying that our Company has been registered as a dealer under Section 22 of the Karnataka Value Added Tax Act, 2003	Value Added Tax Registration Certificate, VAT Sub-Office, Sankeshwar	29610385979	March 21, 2013	Valid until cancelled
5.	Service Tax Registration for taxable service i.e. transport of goods by road	Superintendent of Central Excise, Customs and Service Tax, Nipani Range	AABCV1727HST 001	Date of Issue of Original Registration Certificate: June 7, 2007  Date of last amendment : March 6, 2013	Valid until cancelled
6.	Central Excise Registration Certificate for operating as a manufacturer of excisable goods at Ghataprabha Road, Bellad Bagewadi, Hukkeri, Belgaum Karnataka	Superintendent of Customs and Central Excise, Nipani Range	AABCV1727HX M001	Date of Issue of Original Registration Certificate: June 29, 2003  Date of last amendment : February 27, 2013	Valid until cancelled
7.	Employees Provident Fund Registration	Assistant Provident Fund Commissioner, Sub-regional Office, Hubli	MN/PF/HBL/EN F/40236/659200	August 24, 2006	Valid until cancelled
8.	Certificate of Registration issued under Karnataka Tax on Professions, Trades, Callings and Employments Act, 1976	Professional Tax Officer, Sankeshwar	338118041	February 16, 2013	Valid until cancelled
9.	Certificate of Enrolment issued under Karnataka Tax on Professions, Trades, Callings and Employments Act, 1976	Professional Tax Officer, Sankeshwar	29610385979	April 24, 2013	Valid until cancelled
10.	Certificate of Registration under Goods and Service Tax Act, 2017	Government of India,	29AABCV1727H IZA	September 20, 2017	Valid until cancelled.

11. The Company has also obtained registration under the Central Sales Tax Act, 1956.

## V. INTELLECTUAL PROPERTY

Sr. No	Particulars of the mark	Word/Label Mark	Proprietor	Trademark Number	Issuing Authority	Class	Status
(e)		Device	The Company	2152827	Trade Marks Registry, Chennai	33	Registered
(f)		Device	The Company	2152826	Trade Marks Registry, Chennai	30	Registered

### Pending Approvals

1. Application dated June 23, 2018 for renewal of Crushing License for manufacturing sugar from sugarcane for the year 2018-19 for 8,500 TCD filed under Section 3 of Karnataka Sugar(Regulation of Production) Order, 1975.
2. Application dated August 27, 2019 for renewal of Boiler No. KTK 3478 with the Deputy Director of Boilers, Belgaum Division, Belgaum under Boilers Act, 1923.
3. Application dated August 27, 2019 for renewal of Boiler no. KTK 2760 with the Deputy Director of Boilers, Belgaum Division, Belgaum under Boilers Act, 1923.

### Applications yet to be made

1. The Company had made an application dated June 01, 2017 to the State Excise Department under the Karnataka Excise Act 1965 for renewal of RS-2 license and for manufacture/possession of non-potable Rectified Spirit. The Office of the Commissioner of Excise vide letter dated July 15, 2017 has conveyed that the renewal of the RS-2 license no more falls under the purview of the State Excise Department and is now under the purview of the Central Government pursuant to Notification No. 27/2016 dated May 14, 2016. Thereafter, the Company has made efforts to file the said renewal application with the Central Government but the same has not been accepted since the Central Government is yet to establish the necessary administrative machinery for accepting the said application and issuing the requisite license.
2. The Company is in the process of making application to the Union of Orthodox Jewish Congregations of America for obtaining its certification as to kosher in respect of Natural Alcohol Vinegar.

## SECTION VIII - OTHER REGULATORY AND STATUTORY DISCLOSURES

### Authority for the Offer

The Offer has been authorised by our Board pursuant to a resolution passed at its meeting held on November 20, 2017 and the Shareholders have approved the Offer by a special resolution passed in accordance with Section 62(1) (c) of the Companies Act, 2013, at the EGM held on December 18, 2017.

The Selling Shareholders, pursuant to the Selling Shareholders' Consent Letters, have given their consent to offer their Equity Shares in the Offer. Each Selling Shareholder, severally and not jointly, specifically confirms that, as required under Regulation 26(6) of the SEBI ICDR Regulations, they have held their respective portion of the Offered Shares for a period of at least one year prior to the date of filing of the Draft Red Herring Prospectus.

Further, we confirm that:

- a. none of the Selling Shareholders have/had been debarred from accessing or operating in capital markets under any order or direction passed by SEBI or any other regulatory or governmental authority.
- b. none of the companies, with which the selling shareholders are or were associated as promoters, directors or persons in control have been debarred from accessing or operating in capital markets under any order or direction passed by SEBI or any other regulatory or governmental authority.
- c. none of the Selling Shareholders or any of the entities that selling shareholders are associated with are engaged in securities market related business or are registered with SEBI.
- d. there has been no action taken by the SEBI against any selling shareholders or any entity in which selling shareholders are involved in as promoters or directors or any such action is pending.
- e. none of the Selling Shareholders have been categorised as wilful defaulters by any bank or financial institution or consortium thereof, in accordance with the guidelines on wilful defaulters issued by the Reserve Bank of India.
- f. None of our Selling Shareholders' are/were directors of company which were classified as "Vanishing Company" by MCA.

In – principle Listing Approvals:

1. We have received in-principle approval from BSE for the listing of our Equity Shares pursuant to a letter dated January 12, 2018.
2. We have received in-principle approval from NSE for the listing of our Equity Shares pursuant to a letter dated January 10, 2018.

### Prohibition by SEBI or other Governmental authorities

Our Company, our Promoter, our Directors, the members of the Promoter Group and our Group Companies have not been debarred from accessing or operating in capital markets or buying and selling or dealing in securities, under any order or direction passed by SEBI or any other regulatory or governmental authority / court as on date of this Red Herring Prospectus. The companies, with which our Promoter, our Directors or persons in control of our Company are or were associated as promoters, directors or persons in control have not been debarred from accessing or operating in capital markets under any order or direction passed by SEBI or any other regulatory or governmental authority.

The listing of any securities of our Company or Associates has never been refused at any time by any of the stock exchanges in India or abroad.

### Directors associated with the Securities Market

None of our Directors or any of the entities that our Directors are associated with is engaged in securities market related business or is registered with SEBI. There has been no action taken by the SEBI against our Directors or any entity in which our Directors are involved in as promoters or directors.

## Prohibition with respect to wilful defaulters

Neither our Company, nor our Promoter, Directors, Group Companies, have been categorized as wilful defaulters by any bank or financial institution or consortium thereof, in accordance with the guidelines on wilful defaulters issued by the Reserve Bank of India.

## Eligibility for the Offer

Our Company is eligible for the Offer in accordance with the eligibility criteria provided in Regulation 26(1) of the SEBI ICDR Regulations, and as calculated from the Restated Financial Statements prepared in accordance with the Companies Act, 2013 and restated in accordance with the SEBI ICDR Regulations:

- Our Company has net tangible assets of at least ₹ 300 lakhs (₹ 3 crores) in each of the preceding three full years (of 12 months each) of which not more than 50% are held in monetary assets;
- Our Company has a minimum average pre-tax operating profit of ₹ 1,500.00 lakhs (₹ 15 Crores) calculated on a restated and consolidated basis, during the three most profitable years out of the immediately preceding five years;
- Our Company has a pre-Offer net worth of at least ₹ 100 lakhs (₹ 1 crore) in each of the three preceding full years (of 12 months each);
- the proposed offer size does not exceed five times the pre-offer net worth as per the audited accounts for the year ended March 31, 2019; and
- Our Company has not changed its name in the last one year.

The Company's pre-tax operating profit, net worth, net tangible assets and monetary assets derived from the restated financial statements included in this Red Herring Prospectus as at, and for the financial years ended March 31, 2019, March 31, 2018, March 31, 2017, March 31, 2016 and March 31, 2015 are set forth below:

(₹ in lakhs)

Particulars	FY 2018-19	FY 2017-18	FY 2016-17	FY 2015-16	FY 2014-15
Net Tangible Assets <sup>(1)</sup>	21,149.69	22,887.95	23,248.79	22,609.26	22,989.42
Monetary Assets <sup>(2)</sup>	184.35	745.72	1,273.65	5,164.93	1,992.43
Monetary assets as a percentage of the net tangible assets <sup>(1)(2)</sup>	0.87%	3.26%	5.48%	22.84%	8.67%
Pre-Tax Operating Profit <sup>(3)</sup>	1,139.00	1,034.05	3,432.83	2,226.34	1,168.20
Net Worth <sup>(4)</sup>	21,149.69	22,887.95	23,248.79	22,609.26	22,989.42

Financial Year 2014-15, Financial Year 2015-16 and Financial Year 2016-17 are the three most profitable years out of the five immediately preceding financial years in terms of our Restated Financial Statements with Pre-Tax Operating Profit of ₹ 1,168.20 lakhs, ₹ 2,226.34 lakhs and ₹ 3,432.83 lakhs on a standalone basis, respectively. Our Company's average Pre-Tax Operating Profit based on the three most profitable years out of the five immediately preceding Financial Years in terms of Restated Financial Statements is ₹ 2,275.79 lakhs on a standalone basis.

## Notes

- (1) 'Net tangible assets' is defined as the sum of fixed assets (including capital work-in-progress and excluding revaluation reserves), current assets (excluding deferred tax assets) less current liabilities (excluding deferred tax liabilities).
- (2) 'Monetary assets' comprise of cash on hand, bank balances (including the deposits accounts and interest accrued thereon) and quoted Investments.
- (3) 'Pre-tax operating profits' comprise of profit from operations before finance expenses, other income and exceptional items.

- (4) 'Net worth' has been defined as the aggregate of the paid up share capital, share premium account, and reserves and surplus (excluding revaluation reserve) as reduced by the aggregate of the miscellaneous expenditure (to the extent not adjusted or written-off) and the debit balance of the profit and loss account.

Further, in accordance with Regulation 26(4) of the SEBI ICDR Regulations, our Company shall ensure that the number of prospective allottees to whom the Equity Shares will be allotted will be not less than 1,000 failing which the entire application money shall be refunded. In case of delay, if any, in refund within such timeline as prescribed under applicable laws, our Company shall be liable to pay interest on the application money in accordance with applicable laws.

Our Company is in compliance with the conditions specified in Regulations 4(2) and 4(5)(a) of the SEBI ICDR Regulations.

#### **DISCLAIMER CLAUSE OF SEBI**

**AS REQUIRED, A COPY OF THE DRAFT RED HERRING PROSPECTUS HAS BEEN SUBMITTED TO SEBI. IT IS TO BE DISTINCTLY UNDERSTOOD THAT SUBMISSION OF THE DRAFT RED HERRING PROSPECTUS TO SEBI SHOULD NOT, IN ANY WAY, BE DEEMED OR CONSTRUED TO MEAN THAT THE SAME HAS BEEN CLEARED OR APPROVED BY SEBI. SEBI DOES NOT TAKE ANY RESPONSIBILITY EITHER FOR THE FINANCIAL SOUNDNESS OF ANY SCHEME OR THE PROJECT FOR WHICH THIS OFFER IS PROPOSED TO BE MADE OR FOR THE CORRECTNESS OF THE STATEMENTS MADE OR OPINIONS EXPRESSED IN THE DRAFT RED HERRING PROSPECTUS. THE BOOK RUNNING LEAD MANAGER, ARYAMAN FINANCIAL SERVICES LIMITED HAS CERTIFIED THAT THE DISCLOSURES MADE IN THE DRAFT RED HERRING PROSPECTUS ARE GENERALLY ADEQUATE AND ARE IN CONFORMITY WITH THE SEBI (ISSUE OF CAPITAL AND DISCLOSURE REQUIREMENTS) REGULATIONS, 2009, AS FOR THE TIME BEING IN FORCE. THIS REQUIREMENT IS TO FACILITATE INVESTORS TO TAKE AN INFORMED DECISION FOR MAKING AN INVESTMENT IN THE PROPOSED OFFER.**

**IT SHOULD ALSO BE CLEARLY UNDERSTOOD THAT WHILE THE COMPANY IS PRIMARILY RESPONSIBLE FOR THE CORRECTNESS, ADEQUACY AND DISCLOSURE OF ALL RELEVANT INFORMATION IN THE DRAFT RED HERRING PROSPECTUS, THE BOOK RUNNING LEAD MANAGER, ARYAMAN FINANCIAL SERVICES LIMITED, IS EXPECTED TO EXERCISE DUE DILIGENCE TO ENSURE THAT THE COMPANY DISCHARGES ITS RESPONSIBILITY ADEQUATELY IN THIS BEHALF AND TOWARDS THIS PURPOSE, THE BOOK RUNNING LEAD MANAGER, ARYAMAN FINANCIAL SERVICES LIMITED, HAS FURNISHED TO SEBI A DUE DILIGENCE CERTIFICATE DATED DECEMBER 20, 2017, WHICH READS AS FOLLOWS:**

**WE, THE LEAD MERCHANT BANKERS TO THE ABOVE MENTIONED FORTHCOMING OFFER, STATE AND CONFIRM AS FOLLOWS:**

- 1. WE HAVE EXAMINED VARIOUS DOCUMENTS INCLUDING THOSE RELATING TO LITIGATION LIKE COMMERCIAL DISPUTES, PATENT DISPUTES, DISPUTES WITH COLLABORATORS, ETC. AND OTHER MATERIAL IN CONNECTION WITH THE FINALISATION OF THE DRAFT RED HERRING PROSPECTUS PERTAINING TO THE SAID OFFER;**
- 2. ON THE BASIS OF SUCH EXAMINATION AND THE DISCUSSIONS WITH THE COMPANY, ITS DIRECTORS AND OTHER OFFICERS, OTHER AGENCIES, AND INDEPENDENT VERIFICATION OF THE STATEMENTS CONCERNING THE OBJECTS OF THE OFFER, PRICE JUSTIFICATION AND THE CONTENTS OF THE DOCUMENTS AND OTHER PAPERS FURNISHED BY THE COMPANY, WE CONFIRM THAT:**
  - (A) THE DRAFT RED HERRING PROSPECTUS FILED WITH SEBI IS IN CONFORMITY WITH THE DOCUMENTS, MATERIALS AND PAPERS RELEVANT TO THE OFFER;**
  - (B) ALL THE LEGAL REQUIREMENTS RELATING TO THE OFFER AS ALSO THE REGULATIONS, GUIDELINES, INSTRUCTIONS, ETC. FRAMED / ISSUED BY SEBI, THE CENTRAL GOVERNMENT, AND ANY OTHER COMPETENT AUTHORITY IN THIS BEHALF HAVE BEEN DULY COMPLIED WITH; AND**

(C) THE DISCLOSURES MADE IN THE DRAFT RED HERRING PROSPECTUS ARE TRUE, FAIR AND ADEQUATE TO ENABLE THE INVESTORS TO MAKE A WELL INFORMED DECISION AS TO THE INVESTMENT IN THE PROPOSED OFFER AND SUCH DISCLOSURES ARE IN ACCORDANCE WITH THE REQUIREMENTS OF THE COMPANIES ACT, 1956, THE COMPANIES ACT, 2013, THE SECURITIES EXCHANGE BOARD OF INDIA (ISSUE OF CAPITAL AND DISCLOSURE REQUIREMENTS) REGULATIONS, 2009 AND OTHER APPLICABLE LEGAL REQUIREMENTS.

3. WE CONFIRM THAT BESIDES OURSELVES, ALL THE INTERMEDIARIES NAMED IN THE DRAFT RED HERRING PROSPECTUS ARE REGISTERED WITH SEBI AND THAT TILL DATE SUCH REGISTRATION IS VALID. – NOTED FOR COMPLIANCE
4. WE HAVE SATISFIED OURSELVES ABOUT THE CAPABILITY OF THE UNDERWRITERS TO FULFIL THEIR UNDERWRITING COMMITMENTS. – NOTED FOR COMPLIANCE
5. WE CERTIFY THAT WRITTEN CONSENT FROM PROMOTER HAS BEEN OBTAINED FOR INCLUSION OF THEIR EQUITY SHARES AS PART OF THE PROMOTERS' CONTRIBUTION SUBJECT TO LOCK-IN AND THE EQUITY SHARES PROPOSED TO FORM PART OF PROMOTER'S CONTRIBUTION SUBJECT TO LOCK-IN, SHALL NOT BE DISPOSED / SOLD / TRANSFERRED BY THE PROMOTERS DURING THE PERIOD STARTING FROM THE DATE OF FILING THE DRAFT RED HERRING PROSPECTUS WITH SEBI TILL THE DATE OF COMMENCEMENT OF LOCK-IN PERIOD AS STATED IN THE DRAFT RED HERRING PROSPECTUS.
6. WE CERTIFY THAT REGULATION 33 OF THE SECURITIES AND EXCHANGE BOARD OF INDIA (ISSUE OF CAPITAL AND DISCLOSURE REQUIREMENTS) REGULATIONS, 2009, WHICH RELATES TO SPECIFIED SECURITIES INELIGIBLE FOR COMPUTATION OF PROMOTERS CONTRIBUTION, HAS BEEN DULY COMPLIED WITH AND APPROPRIATE DISCLOSURES AS TO COMPLIANCE WITH THE SAID REGULATION HAVE BEEN MADE IN THE DRAFT RED HERRING PROSPECTUS. – NOTED FOR COMPLIANCE
7. WE UNDERTAKE THAT SUB-REGULATION (4) OF REGULATION 32 AND CLAUSE (C) AND (D) OF SUB-REGULATION (2) OF REGULATION 8 OF THE SECURITIES AND EXCHANGE BOARD OF INDIA (ISSUE OF CAPITAL AND DISCLOSURE REQUIREMENTS) REGULATIONS, 2009 SHALL BE COMPLIED WITH. WE CONFIRM THAT ARRANGEMENTS HAVE BEEN MADE TO ENSURE THAT PROMOTERS' CONTRIBUTION SHALL BE RECEIVED AT LEAST ONE DAY BEFORE THE OPENING OF THE OFFER. WE UNDERTAKE THAT AUDITORS' CERTIFICATE TO THIS EFFECT SHALL BE DULY SUBMITTED TO SEBI. WE FURTHER CONFIRM THAT ARRANGEMENTS HAVE BEEN MADE TO ENSURE THAT PROMOTERS' CONTRIBUTION SHALL BE KEPT IN AN ESCROW ACCOUNT WITH A SCHEDULED COMMERCIAL BANK AND SHALL BE RELEASED TO THE COMPANY ALONG WITH THE PROCEEDS OF THE PUBLIC OFFER. – NOT APPLICABLE
8. WE CERTIFY THAT THE PROPOSED ACTIVITIES OF THE COMPANY FOR WHICH THE FUNDS ARE BEING RAISED IN THE PRESENT OFFER FALL WITHIN THE 'MAIN OBJECTS' LISTED IN THE OBJECT CLAUSE OF THE MEMORANDUM OF ASSOCIATION OF THE COMPANY OR OTHER CHARTER OF THE COMPANY AND THAT THE ACTIVITIES WHICH HAVE BEEN CARRIED OUT UNTIL NOW ARE VALID IN TERMS OF THE OBJECT CLAUSE OF ITS MEMORANDUM OF ASSOCIATION. – COMPLIED WITH TO THE EXTENT APPLICABLE.
9. WE CONFIRM THAT NECESSARY ARRANGEMENTS HAVE BEEN MADE TO ENSURE THAT THE MONEYS RECEIVED PURSUANT TO THE OFFER ARE KEPT IN A SEPARATE BANK ACCOUNT AS PER THE PROVISIONS OF SUB-SECTION (3) OF SECTION 40 OF THE COMPANIES ACT, 2013 AND THAT SUCH MONEYS SHALL BE RELEASED BY THE SAID BANK ONLY AFTER PERMISSION IS OBTAINED FROM ALL THE STOCK EXCHANGES MENTIONED IN THE DRAFT RED HERRING PROSPECTUS. WE FURTHER CONFIRM THAT THE AGREEMENT ENTERED INTO BETWEEN THE BANKERS TO THE OFFER AND THE COMPANY SPECIFICALLY CONTAINS THIS CONDITION – NOTED FOR COMPLIANCE.
10. WE CERTIFY THAT A DISCLOSURE HAS BEEN MADE IN THE DRAFT RED HERRING PROSPECTUS THAT THE INVESTORS SHALL BE GIVEN AN OPTION TO GET THE SHARES IN



**DEMAT OR PHYSICAL MODE - NOT APPLICABLE. UNDER SECTION 29 OF THE COMPANIES ACT, 2013, EQUITY SHARES IN THE OFFER HAVE TO BE ISSUED IN DEMATERIALISED FORM ONLY;**

11. WE CERTIFY THAT ALL THE APPLICABLE DISCLOSURES MANDATED IN THE SECURITIES AND EXCHANGE BOARD OF INDIA (ISSUE OF CAPITAL AND DISCLOSURE REQUIREMENTS) REGULATIONS, 2009 HAVE BEEN MADE IN ADDITION TO DISCLOSURES WHICH, IN OUR VIEW, ARE FAIR AND ADEQUATE TO ENABLE THE INVESTOR TO MAKE A WELL INFORMED DECISION.
12. WE CERTIFY THAT THE FOLLOWING DISCLOSURES HAVE BEEN MADE IN THE DRAFT RED HERRING PROSPECTUS:
  - (A) AN UNDERTAKING FROM THE COMPANY THAT AT ANY GIVEN TIME, THERE SHALL BE ONLY ONE DENOMINATION FOR THE EQUITY SHARES OF THE COMPANY; AND
  - (B) AN UNDERTAKING FROM THE COMPANY THAT IT SHALL COMPLY WITH SUCH DISCLOSURE AND ACCOUNTING NORMS SPECIFIED BY SEBI FROM TIME TO TIME.
13. WE UNDERTAKE TO COMPLY WITH THE REGULATIONS PERTAINING TO ADVERTISEMENT IN TERMS OF THE SECURITIES AND EXCHANGE BOARD OF INDIA (ISSUE OF CAPITAL AND DISCLOSURE REQUIREMENTS) REGULATIONS, 2009 WHILE MAKING THE OFFER – **NOTED FOR COMPLIANCE**
14. WE ENCLOSE A NOTE EXPLAINING HOW THE PROCESS OF DUE DILIGENCE HAS BEEN EXERCISED BY US IN VIEW OF THE NATURE OF CURRENT BUSINESS BACKGROUND OF THE COMPANY, SITUATION AT WHICH THE PROPOSED BUSINESS STANDS, THE RISK FACTORS, PROMOTERS EXPERIENCE, ETC.
15. WE ENCLOSE A CHECKLIST CONFIRMING REGULATION-WISE COMPLIANCE WITH THE APPLICABLE PROVISIONS OF THE SECURITIES AND EXCHANGE BOARD OF INDIA (ISSUE OF CAPITAL AND DISCLOSURE REQUIREMENTS) REGULATIONS, 2009, CONTAINING DETAILS SUCH AS THE REGULATION NUMBER, ITS TEXT, THE STATUS OF COMPLIANCE, PAGE NUMBER OF THE DRAFT RED HERRING PROSPECTUS WHERE THE REGULATION HAS BEEN COMPLIED WITH AND OUR COMMENTS, IF ANY.
16. WE ENCLOSE STATEMENT ON ‘PRICE INFORMATION OF PAST ISSUES HANDLED BY MERCHANT BANKERS (WHO ARE RESPONSIBLE FOR PRICING THIS OFFER)’, AS PER FORMAT SPECIFIED BY THE SEBI THROUGH CIRCULAR;
17. WE CERTIFY THAT PROFITS FROM RELATED PARTY TRANSACTIONS HAVE ARISEN FROM LEGITIMATE BUSINESS TRANSACTIONS – **COMPLIED WITH TO THE EXTENT OF THE RELATED PARTY TRANSACTIONS REPORTED IN ACCORDANCE WITH ACCOUNTING STANDARD 18 / IND AS 24 IN THE FINANCIAL STATEMENTS OF THE COMPANY INCLUDED IN THE DRAFT OFFER DOCUMENT.**
18. WE CERTIFY THAT THE ENTITY IS ELIGIBLE UNDER 106Y (1) (A) OR (B) (AS THE CASE MAY BE) TO LIST ON THE INSTITUTIONAL TRADING PLATFORM, UNDER CHAPTER XC OF THESE REGULATIONS. (IF APPLICABLE). – **NOT APPLICABLE**

The filing of this Red Herring Prospectus does not, however, absolve our Company from any liabilities under Section 34 or Section 36 of the Companies Act, 2013 or from the requirement of obtaining such statutory or other clearances as may be required for the purpose of the Offer. SEBI further reserves the right to take up, at any point of time, with the BRLM any irregularities or lapses in the Draft Red Herring Prospectus, this Red Herring Prospectus and the Prospectus.

The filing of this Red Herring Prospectus does not absolve the Selling Shareholders from any liability to the extent the statements made by them in respect of the Equity Shares being offered by them, respectively under the Offer for Sale, under Section 34 and Section 36 of the Companies Act, 2013.

All legal requirements pertaining to the Offer will be complied with at the time of filing of the Red Herring Prospectus with the RoC in terms of Section 32 of the Companies Act, 2013. All legal requirements pertaining to the Offer will be complied with at the time of registration of the Prospectus with the RoC in terms of Sections 26, 28 and 32 of the Companies Act, 2013.

### Price information of past issues handled by the BRLM

Price information of past issues (during current financial year and two financial years preceding the current financial year) handled by Aryaman Financial Services Limited.

Sr. No.	Issue Name	Issue size (₹ Cr.)	Issue Price (₹)	Listing date	Opening price on listing date	+/- % change in Price on closing price, [+/- % change in closing benchmark]- 30 <sup>th</sup> calendar days from listing		+/- % change in Price on closing price, [+/- % change in closing benchmark]- 90 <sup>th</sup> calendar days from listing		+/- % change in Price on closing price, [+/- % change in closing benchmark]- 180 <sup>th</sup> calendar days from listing	
1	Transpact Enterprises Limited	1.35	130.00	05/09/2019	132.50	N.A	N.A	N.A	N.A	N.A	N.A
2	Meera Industries Limited <sup>(1)</sup>	11.75	225.00	26/06/2019	215.00	-6.04%	-4.32%	N.A	N.A	N.A	N.A
3	Roopshri Resorts Ltd	3.60	20.00	01/04/2019	20.25	1.25%	0.41%	1.25%	1.34%	N.A	N.A
4	Gleam Fabmat Ltd	3.12	10.00	05/03/2019	9.00	-36.50%	6.15%	-45.40%	10.50%	-67.50%	2.44%
5	DRS Dilip Roadlines Ltd	31.50	75.00	10/12/2018	75.15	1.33%	3.50%	0.33%	5.21%	0.67%	13.18%
6	Roni Households Ltd	3.00	20.00	03/12/2018	20.05	25.00%	-0.96%	25.00%	-0.49%	25.50%	9.58%
7	Marine Electricals India Ltd	42.87	66.00	11/10/2018	66.60	21.21%	3.43%	24.17%	6.06%	59.85%	14.04%
8	Silgo Retail Ltd	4.88	36.00	10/10/2018	36.45	0.00%	1.20%	0.00%	3.27%	1.39%	10.94%
9	Sky Gold Ltd	25.56	180	03/10/2018	180.45	2.22%	-2.68%	0.58%	0.78%	1.11%	8.05%
10	Saketh Exim Ltd	9.44	69.00	13/08/2018	69.30	0.00%	0.12%	3.48%	-6.79%	18.84%	-3.63%

<sup>(1)</sup> Equity Shares of Meera Industries Limited was listed on May 15, 2017 on BSE Limited. Aryaman Financial Services Limited was appointed as lead manager for the Further Public Issue by the Company on BSE Limited pursuant to which its additional shares were listed on June 26, 2019.

Summary statement of price information of past issues (during current financial year and two financial years preceding the current financial year) handled by Aryaman Financial Services Limited

Financial Year	Total no. of IPOs	Total Funds Raised (₹ in Cr.)	Nos. of IPOs trading at discount - 30 <sup>th</sup> calendar day from listing day			Nos. of IPOs trading at premium - 30 <sup>th</sup> calendar day from listing day			Nos. of IPOs trading at discount - 180 <sup>th</sup> calendar day from listing day			Nos. of IPOs trading at premium - 180 <sup>th</sup> calendar day from listing day		
			Over 50%	Between 25-50%	Less than 25%	Over 50%	Between 25-50%	Less than 25%	Over 50%	Between 25-50%	Less than 25%	Over 50%	Between 25-50%	Less than 25%
2019-20	3 <sup>(1)</sup>	16.70	-	-	1	-	-	1	-	-	-	-	-	-
2018-19	14 <sup>(2)</sup>	327.66	-	-	1	-	1	9	-	-	2	1	1	9
2017-18	16	318.24	1	1	4	1	1	8	3	3	3	0	0	6

<sup>(1)</sup> Details indicated in 2019-20 are for the public issues completed as on date

<sup>(2)</sup> As on the 30th and 90th Calendar day from the listing day, the price of Silgo Retail Limited and 30th Calendar day from the listing day, the price of Saketh Exim Limited is exactly equal to its Issue Price and hence it is neither trading at Premium or Discount

**Notes:**

- a) *Since the listing date of Transpact Enterprises Limited, was September 05, 2019, information related to closing price and benchmark index as on the 30<sup>th</sup> Calendar day, 90<sup>th</sup> Calendar day and 180<sup>th</sup> Calendar day from the listing date is not available.*
- b) *Since the listing date of Meera Industries Limited, was June 26, 2019, information related to closing price and benchmark index as on the 90<sup>th</sup> Calendar day and 180<sup>th</sup> Calendar day from the listing date is not available.*
- c) *Since the listing date of Roopshri Resorts Limited was April 1, 2019, information related to closing price and benchmark index as on the 180<sup>th</sup> Calendar day from the listing date is not available.*
- d) *The respective Designated Stock Exchange for each Issue has been considered as the Benchmark index for each of the above Issues.*
- e) *In the event any day falls on a holiday, the price/index of the immediate preceding working day has been considered. If the stock was not traded on the said calendar days from the date of listing, the share price is taken of the immediately preceding trading day.*
- f) *Source: www.bseindia.com and www.nseindia.com BSE Sensex and Nifty Fifty as the Benchmark Indices.*

**Track record of past issues handled by the Lead Manager**

For details regarding the track record of the BRLM to the Offer as specified in Circular reference CIR/MIRSD/1/ 2012 dated January 10, 2012 issued by the SEBI, please see the website of Aryaman Financial Services Limited – [www.afsl.co.in](http://www.afsl.co.in)

**Disclaimer from our Company, the Selling Shareholders and the BRLM**

Our Company, the Selling Shareholders and the BRLM accept no responsibility for statements made otherwise than in this Red Herring Prospectus or in the advertisements or any other material issued by or at our Company's instance and anyone placing reliance on any other source of information would be doing so at his or her own risk.

**CAUTION**

The BRLM accept no responsibility, save to the limited extent as provided in the MoU for Offer Management entered into among the BRLM, our Company and the Selling Shareholders dated December 18, 2017 and the Underwriting Agreement to be entered into between the Underwriters the Selling Shareholders and our Company. All information shall be made available by our Company, the Selling Shareholders and the BRLM to the public and investors at large and no selective or additional information would be available for a section of the investors in any manner whatsoever, including at road show presentations, in research or sales reports, at bidding centre's or elsewhere.

None among our Company, Selling Shareholders or any member of the Syndicate shall be liable for any failure in uploading the Bids due to faults in any software / hardware system or otherwise. Bidders will be required to confirm and will be deemed to have represented to our Company, Underwriters and their respective directors, officers, agents, affiliates, and representatives that they are eligible under all applicable laws, rules, regulations, guidelines and approvals to acquire the Equity Shares and will not issue, sell, pledge, or transfer the Equity Shares to any person who is not eligible under any applicable laws, rules, regulations, guidelines and approvals to acquire the Equity Shares.

Our Company, Selling Shareholders, Underwriters and their respective directors, officers, agents, affiliates, and representatives accept no responsibility or liability for advising any investor on whether such investor is eligible to acquire the Equity Shares. The BRLM and their respective associates and affiliates may engage in transactions with, and perform services for, our Company, Associates, the Promoter and Promoter Group and their respective directors and officers, group companies, affiliates or associates or third parties in the ordinary course of business and have engaged, or may in the future engage, in underwriting, commercial banking and investment banking transactions with our Company, Associates, the Promoter and Promoter Group and their respective group companies, affiliates or associates or third parties, for which they have received, and may in the future receive, compensation.

None among our Company, the Selling Shareholders or any member of the Syndicate shall be liable for any failure in (i) uploading the Bids due to faults in any software/ hardware system or otherwise or (ii) the blocking of Bid Amount in the ASBA Account on receipt of instructions from the Sponsor Bank on account of any errors, omissions or non compliance by various parties involved in, or any other fault, malfunctioning or breakdown in, or otherwise, in the UPI Mechanism.

### **Disclaimer in Respect of Jurisdiction**

This Offer is being made in India to persons resident in India (including Indian nationals resident in India, Hindu Undivided Families (“HUFs”), companies, other corporate bodies and societies registered under the applicable laws in India and authorized to invest in equity shares, Indian Mutual Funds registered with the SEBI, Indian financial institutions, commercial banks, regional rural banks, co-operative banks (subject to permission from the RBI), or trusts under the applicable trust laws, and who are authorized under their constitution to hold and invest in equity shares, public financial institutions as specified under Section 2(72) of the Companies Act, 2013, venture capital funds, permitted insurance companies and pension funds and, to permitted non-residents including Eligible NRIs, Eligible Qualified Foreign Investors (“QFIs”), Alternative Investment Funds (“AIFs”), Foreign Institutional Investors (“FIIs”), Foreign Portfolio Investors registered with SEBI (“FPIs”) and QIBs. Any dispute arising out of the Offer will be subject to the jurisdiction of appropriate court(s) in Mumbai, India only.

No action has been or will be taken to permit a public offering in any jurisdiction where action would be required for that purpose, except that the Draft Red Herring Prospectus has been filed with SEBI for its observations and Stock Exchanges. Accordingly, the Equity Shares, offered in the Offer may not be offered or sold, directly or indirectly, and this Red Herring Prospectus may not be distributed, in any jurisdiction, except in accordance with the legal requirements applicable in such jurisdiction.

**The Equity Shares have not been and will not be registered under the U.S. Securities Act, 1933 or any other applicable law of the United States and, unless so registered, and may not be offered or sold within the United States or to, or for the account or benefit of, U.S. persons (as defined in Regulation S under the Securities Act), except pursuant to an exemption from, or in a transaction not subject to, the registration requirements of the Securities Act and applicable state securities laws. Accordingly, the Equity Shares are being offered and sold outside the United States in offshore transactions in reliance on Regulation S under the Securities Act.**

**The Equity Shares have not been and will not be registered, listed or otherwise qualified in any other jurisdiction outside India and may not be offered or sold, and Bids may not be made by persons in any such jurisdiction, except in compliance with the applicable laws of such jurisdiction.**

**Bidders are advised to ensure that any Bid from them does not exceed investment limits or maximum number of Equity Shares that can be held by them under applicable law.**

Neither the delivery of this Red Herring Prospectus nor any sale hereunder shall, under any circumstances, create any implication that there has been no change in the affairs of our Company from the date hereof or that the information contained herein is correct as of any time subsequent to this date.

### **Disclaimer Clause of BSE**

“BSE Limited (“the Exchange”) has given vide its letter dated January 12, 2018 permission to this Company to use the Exchange’s name in this offer document as one of the stock exchanges on which this company’s securities are proposed to be listed. The Exchange has scrutinised this offer document for its limited internal purpose of deciding on the matter of granting the aforesaid permission to this Company. The Exchange does not in any manner:

- a. warrant, certify or endorse the correctness or completeness of any of the contents of this offer document; or
- b. warrant that this Company’s securities will be listed or will continue to be listed on the Exchange; or
- c. take any responsibility for the financial or other soundness of this Company, its promoter, its management or any scheme or project of this Company;

and it should not for any reason be deemed or construed that this offer document has been cleared or approved by the Exchange. Every person who desires to apply for or otherwise acquires any securities of this Company may do so pursuant to independent inquiry, investigation and analysis and shall not have any claim against the Exchange

whatsoever by reason of any loss which may be suffered by such person consequent to or in connection with such subscription/ acquisition whether by reason of anything stated or omitted to be stated herein or for any other reason whatsoever.

### **Disclaimer Clause of NSE**

As required, a copy of this Offer Document has been submitted to National Stock Exchange of India Limited (hereinafter referred to as NSE). NSE has given vide its letter Ref.: NSE/LIST/0016 dated January 10, 2018 permission to the Issuer to use the Exchange's name in this Offer Document as one of the stock exchanges on which this Issuer's securities are proposed to be listed. The Exchange has scrutinized this draft offer document for its limited internal purpose of deciding on the matter of granting the aforesaid permission to this Issuer. It is to be distinctly understood that the aforesaid permission given by NSE should not in any way be deemed or construed that the offer document has been cleared or approved by NSE; nor does it in any manner warrant, certify or endorse the correctness or completeness of any of the contents of this offer document; nor does it warrant that this Issuer's securities will be listed or will continue to be listed on the Exchange; nor does it take any responsibility for the financial or other soundness of this Issuer, its promoter, its management or any scheme or project of this Issuer.

Every person who desires to apply for or otherwise acquire any securities of this Issuer may do so pursuant to independent inquiry, investigation and analysis and shall not have any claim against the Exchange whatsoever by reason of any loss which may be suffered by such person consequent to or in connection with such subscription /acquisition whether by reason of anything stated or omitted to be stated herein or any other reason whatsoever.

### **Filing of Prospectus with SEBI and the RoC**

A copy of the Draft Red Herring Prospectus has been filed with SEBI at 7th Floor, 756-L, Anna Salai, Chennai – 600 002, Tamil Nadu.

A copy of the Red Herring Prospectus, along with the documents required to be filed, will be delivered to the RoC in accordance with Section 32 of the Companies Act, 2013, and a copy of the Prospectus required to be filed under Section 26 of the Companies Act, 2013 will be delivered to the RoC at 'E' Wing, 2<sup>nd</sup> Floor, Kendriya Sadan, Bangalore – 560 034.

### **Listing**

The Equity Shares issued through the Red Herring Prospectus are proposed to be listed on BSE and NSE. Applications will be made to the BSE and the NSE for permission to list the Equity Shares and for an official quotation of the Equity Shares of our Company. BSE Ltd. shall be the Designated Stock Exchange with which the Basis of Allotment will be finalised.

If the permissions to deal in, and for an official quotation of, the Equity Shares are not granted by any of the Stock Exchanges mentioned above, our Company and the Selling Shareholders will forthwith repay without interest, all moneys received from the applicants in pursuance of the Red Herring Prospectus as required by applicable law. If such money is not repaid within the prescribed time, then our Company, the Selling Shareholders and every officer in default shall be liable to repay the money, with interest, as prescribed under applicable law.

Our Company shall ensure that all steps for the completion of the necessary formalities for listing and commencement of trading of the Equity Shares at all the Stock Exchanges mentioned above are taken within six Working Days from the Bid / Offer Closing Date. Further, the Selling Shareholders confirm that they shall extend all reasonable co-operation required by our Company, the BRLM for the completion of the necessary formalities for listing and commencement of trading at all the Stock Exchanges where the Equity Shares are proposed to be listed within six Working Days of the Bid / Offer Closing Date or such other timeline as prescribed by law.

The Selling Shareholders severally and not jointly undertake to provide such reasonable support and extend reasonable cooperation as may be requested by our Company, to the extent such support and cooperation is required from such party to facilitate the process of listing and commencement of trading of the Equity Shares on the Stock Exchanges.

Expenses for the Offer shall be shared amongst the Company and the Selling Shareholders in the manner specified in the section entitled "*Objects of the Offer*" on page no. 102 of this Red Herring Prospectus.



## **Impersonation**

Attention of the Bidders is specifically drawn to the provisions of sub-section (1) of Section 38 of the Companies Act, 2013 which is reproduced below:

“Any person who –

- a) *makes or abets making of an application in a fictitious name to a company for acquiring, or subscribing for, its securities, or*
- b) *makes or abets making of multiple applications to a company in different names or in different combinations of his name or surname for acquiring or subscribing for its securities; or*
- c) *otherwise induces directly or indirectly a company to allot, or register any transfer of, securities to him, or to any other person in a fictitious name, shall be liable for action under section 447.”*

The liability prescribed under Section 447 of the Companies Act, 2013 includes imprisonment for a term of not less than six months extending up to 10 years (provided that where the fraud involves public interest, such term shall not be less than three years) and fine of an amount not less than the amount involved in the fraud, extending up to three times of such amount.

## **Consents**

Consents in writing of our Directors; our Company Secretary and Compliance Officer, our Chief Financial Officer; our Statutory Auditors; Bankers to our Company; Share Escrow Agent<sup>(1)</sup>; Escrow Collection Bank(s)<sup>(1)</sup>; Refund Bank(s)<sup>(1)</sup>; Syndicate Members<sup>(1)</sup>; BRLM, the Registrar, Underwriter(s)<sup>(1)</sup> and the Legal Advisor to the Offer to act in their respective capacities, have been obtained and will be filed along with a copy of the Red Herring Prospectus with the RoC as required under Sections 26 and Section 32 of the Companies Act and such consents have not been withdrawn up to the time of delivery of the Red Herring Prospectus for registration with the RoC.

<sup>(1)</sup> *The aforesaid will be appointed prior to filing of the Red Herring Prospectus with RoC and their consents as above would be obtained prior to the filing of the Red Herring Prospectus with RoC.*

In accordance with the Companies Act, 2013 and the SEBI ICDR Regulations, the Statutory Auditors, M/s. Gojanur & Co, Chartered Accountants, have given their written consent to the inclusion of the report dated July 08, 2019 on Restated Financial Statements and the report dated July 08, 2019 on the Statement of Tax Benefits in this Red Herring Prospectus and such consent have not been withdrawn as on the date of this Red Herring Prospectus.

## **Expert Opinion**

Except for the Statutory Auditor’s report dated July 08, 2019 on the Restated Financial Statements of our Company and the report dated July 08, 2019 on the Statement of Tax Benefits, our Company has not obtained any expert opinions.

However, the term “expert” shall not be construed to mean an “expert” as defined under the U.S. Securities Act.

## **Offer Expenses**

The expenses of this Offer include, among others, underwriting and management fees, selling commissions, bidding charges, printing and distribution expenses, legal fees, statutory advertisement expenses, registrar and depository fees, filing fees, auditor’s fees and listing fees. For further details of Offer expenses, please see the section entitled “*Objects of the Offer*” on page no. 102 of this Red Herring Prospectus.

Expenses for the Offer shall be shared amongst the Company and the Selling Shareholders in the manner specified in the section entitled “*Objects of the Offer – Offer Related Expenses*” on page no. 105 of this Red Herring Prospectus.

## **Fees payable to the Registrar to the Offer**

The fees payable by our Company and the Selling Shareholders to the Registrar to the Offer for processing of applications, data entry, printing of Allotment Advice / CAN / refund order, preparation of refund data on magnetic tape, printing of bulk mailing register will be as per the agreement dated November 27, 2017 entered into, between our



Company, the Selling Shareholders and the Registrar to the Offer a copy of which is available for inspection at the Registered Office.

The Registrar to the Offer will be reimbursed for all out-of-pocket expenses including cost of stationery, postage, and stamp duty and communication expenses. Adequate funds will be provided to the Registrar to the Offer to enable it to send refund orders or Allotment advice by registered post / speed post / under certificate of posting.

#### **Fees, Brokerage and Selling Commission payable**

The total fees payable to the BRLM, Underwriters and Syndicate Members (including underwriting commission, selling commission and reimbursement of their out-of-pocket expense) will be as per the MoU dated December 18, 2017, Underwriting Agreement dated [●] and the Syndicate Agreement dated August 26, 2019.

### **CAPITAL ISSUE DURING THE LAST FIVE YEARS**

#### **Previous Rights and Public Issues**

There have been no public or rights issues undertaken by our Company during the five years preceding the date of this Red Herring Prospectus. However, during the period October 01, 2007 to March 31, 2008, we had made certain allotments and in FY 2013-14 there have been certain transfers which may be perceived as a Public Offer. For details of the allotment and transfers and regarding the developments in the said matter please refer the “*Risk Factor - We have in the past, made certain issuances and allotments of our equity shares which may not be in compliance with the applicable provisions and rules of the Companies Act, 1956.*” and “*Capital Structure – Notes to Capital Structure*” on page nos. 17 and 70 of this Red Herring Prospectus.

#### **Previous Issues of Shares otherwise than for Cash**

Except as disclosed in the chapter “*Capital Structure*” on page no. 69 of this Red Herring Prospectus, our Company has not issued any securities for consideration other than cash.

#### **Underwriting commission, brokerage and selling commission on previous issues**

Since this is the initial public offering of the Equity Shares, no sum has been paid or is payable as commission or brokerage for subscribing to or procuring for, or agreeing to procure subscription for any of the Equity Shares of our Company since inception.

#### **Capital Issues in the last three (3) years by Listed Group Companies / Subsidiaries / Associates**

None of our Group Companies / Associates is listed on any Stock Exchange and hence there is no Capital Issue. Further, we do not have any subsidiary as on date of this Red Herring Prospectus.

### **PERFORMANCE VIS-À-VIS OBJECTS**

#### **Issuer Company**

Our Company has not undertaken any previous public or rights issue in the last 10 years preceding the date of this Red Herring Prospectus.

#### **Listed Group Companies / Subsidiaries / Associate Companies**

None of our Group Companies / Associates is listed on any Stock Exchange and has not made any rights and public issues in the past ten (10) years. Further, we do not have any subsidiary as on date of this Red Herring Prospectus.

### **OUTSTANDING DEBENTURES OR BOND ISSUES OR REDEEMABLE PREFERENCE SHARES AND OTHER INSTRUMENTS ISSUED BY THE COMPANY**

Except as stated in the chapter “*Capital Structure*” and “*History and Certain Corporate Matters*” on page nos. 69 and 166 respectively, our Company has no outstanding debentures, bonds or redeemable preference shares as of the date of this Red Herring Prospectus.

## Partly Paid-Up Shares

As on the date of this Red Herring Prospectus, there are no partly paid up Equity Shares of our Company.

## Stock Market Data for our Equity Shares of our Company

This being an initial public offering of our Company, the Equity Shares of our Company are not listed on any stock exchange.

## DISPOSAL OF INVESTOR GRIEVANCES

### Mechanism for redressal of investor grievances

The agreement dated November 27, 2017 between the Registrar to the Offer, the Selling Shareholders and our Company provides for retention of records with the Registrar to the Offer for a period of at least three years from the last date of despatch of the letters of Allotment, demat credit and refund orders to enable the investors to approach the Registrar to the Offer for redressal of their grievances.

All grievances relating to the Offer may be addressed to the Registrar to the Offer, with a copy to the relevant SCSB and the Syndicate Members at the Specified Locations with whom the Bid cum Application Form was submitted.

All grievances relating to the Offer may be addressed to the Registrar to the Offer, giving full details such as name, application number, address of the applicant, number of Equity Shares applied for, the Bid Amount paid on submission of the Bid cum Application Form, the Depository Participant and the bank branch or collection centre where the Bid cum Application Form was submitted.

In addition to the information indicated above, the ASBA Bidder should also specify the Designated Branch or the collection centre of the SCSB or the address of the centre of the Syndicate Member at the Specified Locations or the Registered Broker at the Broker Centre where the Bid cum Application Form was submitted by the ASBA Bidder.

Further, with respect to the Bid cum Application Forms submitted with the Registered Brokers, the investor shall also enclose the acknowledgment from the Registered Broker in addition to the documents/information mentioned hereinabove.

The Registrar to the Offer shall obtain the required information from the SCSBs for addressing any clarifications or grievances of ASBA Bidders. Our Company, the Selling Shareholders, the BRLM and the Registrar to the Offer accept no responsibility for errors, omissions, commission or any acts of SCSBs including any defaults in complying with its obligations under applicable ICDR Regulations. Investors can contact the Compliance Officer or the Registrar to the Offer in case of any pre-Offer or post-Offer related problems such as non-receipt of letters of Allotment, non-credit of Allotted Equity Shares in the respective beneficiary account, non-receipt of refund intimations and non-receipt of funds by electronic mode.

### Disposal of Investor Grievances by our Company

Our Company estimates that the average time required by our Company or the Registrar to the Offer or the SCSB in case of ASBA Bidders, for the redressal of routine investor grievances shall be 10 Working Days from the date of receipt of the complaint. In case of non-routine complaints and complaints where external agencies are involved, our Company will seek to redress these complaints as expeditiously as possible.

Our Board by a resolution on December 18, 2017 re-constituted the Stakeholders Relationship Committee. The composition of the current Stakeholders Relationship Committee is as follows:

Name of the Member	Nature of Directorship	Designation in Committee
Shivanand Tubachi	Non Executive Independent Director	Chairman
Lava Katti	Whole-time Director	Member
Nikhil Katti	Managing Director	Member

For details, please refer to the chapter “Our Management” on page no. 171 of this Red Herring Prospectus.

Our Company has appointed Sneha Patil, Company Secretary of our Company, as Compliance Officer who would directly deal with SEBI office with respect to implementation of various laws, rules, regulations and other directives issued by SEBI and matters related to investor complaints. For details, please refer the chapter titled “*General Information*” on page no. 61 of this Red Herring Prospectus.

#### **Status of Investor Complaints**

We confirm that we have not received any investor complaint during the three years preceding the date of this Red Herring Prospectus and also there are no pending investor complaints as on the date of this Red Herring Prospectus.

#### **Disposal of Investor Grievances by Listed Companies under the same Management as the Company**

No company under the same management as the Company has made any public issue (including any rights issues to the public) during the last three years and hence there are no pending investor grievances.

#### **Changes in Auditors**

Except as disclosed below, there has been no change in the statutory auditors of our Company during the last three years preceding the date of this Red Herring Prospectus:

<b>Sr. No.</b>	<b>Date</b>	<b>From</b>	<b>To</b>
1.	September 30, 2017	P.G. Ghali & Co, Chartered Accountants	Gojanur & Co, Chartered Accountants

#### **Capitalization of Reserves or Profits**

Our Company has not capitalized its reserves or profits at any time during the last five years, except as stated in the chapter “*Capital Structure*” on page no. 69 of this Red Herring Prospectus.

#### **Revaluation of Assets**

Our Company has not re – valued its assets since incorporation.

## SECTION IX – OFFER RELATED INFORMATION

### TERMS OF THE OFFER

The Equity Shares being offered and transferred pursuant to this Offer are subject to the provisions of the Companies Act, the SCRA, SCRR, SEBI ICDR Regulations, our Memorandum and Articles of Association, the terms of the Draft Red Herring Prospectus, this Red Herring Prospectus, the Prospectus, the Abridged Prospectus, the Bid cum Application Form, the Revision Form, CAN, the Allotment Advice, the SEBI Listing Regulations and other terms and conditions as may be incorporated in the Allotment Advice and other documents or certificates that may be executed in respect of this Offer. The Equity Shares shall also be subject to all applicable laws, guidelines, rules, notifications and regulations relating to the offer of capital and listing and trading of securities offered from time to time by the SEBI, the GoI, the Stock Exchanges, the RoC, the RBI, the FIPB and/or other authorities, as in force on the date of this Offer and to the extent applicable or such other conditions as may be prescribed by such governmental, regulatory or statutory authority while granting its approval for the Offer.

#### Offer for Sale

The Offer consists of a Fresh Offer by our Company and an Offer for Sale by the Selling Shareholders. The object of the Offer for Sale is to allow the Selling Shareholders to sell an aggregate of up to 70,00,000 Equity Shares held by them, aggregating up to ₹ [●] lakhs. All Offer related expenses shall be shared by our Company and the Selling Shareholders in proportion to the number of Equity Shares being issued or offered, as the case may be, by each of them in the Fresh Offer and the Offer for Sale, in accordance with applicable law. Any payments by our Company in relation to the Offer on behalf of the Selling Shareholders shall be reimbursed by the Selling Shareholders to our Company in proportion to the Equity Shares being offered for sale by each of the Selling Shareholders in the Offer.

#### Ranking of the Equity Shares

The Equity Shares being offered and transferred in the Offer shall be subject to the provisions of the Companies Act, 2013, Companies Act, 1956 (to the extent applicable), our Memorandum and Articles of Association and shall rank *pari passu* in all respects with the existing Equity Shares including rights in respect of dividend and other corporate benefits if any, declared by our Company after the date of Allotment. For further details, see “*Main Provisions of the Articles of Association*” on page no. 347 of this Red Herring Prospectus.

#### Mode of Payment of Dividend

Our Company shall pay dividends, if declared, to shareholders of our Company as per the provisions of the Companies Act, 2013, our Memorandum and Articles, the SEBI Listing Regulations and other applicable law. All dividends, if any, declared by our Company after the date of Allotment (pursuant to the transfer of Equity Shares from the Offer for Sale), will be payable to the Bidders who have been Allotted Equity Shares in the Offer, for the entire year, in accordance with applicable law. For further details in relation to dividends, see “*Dividend Policy*” and “*Main Provisions of the Articles of Association*” on page nos. 201 and 347, respectively of this Red Herring Prospectus.

#### Face Value and Offer Price

The face value of the Equity Shares is ₹ 10 each. The Floor Price of Equity Shares is ₹ [●] per Equity Share and the Cap Price is ₹ [●] per Equity Share. The Price Band and minimum Bid lot size for the Offer will be decided by our Company and the Selling Shareholders, in consultation with the BRLM, and advertised all editions of the English national daily newspaper Business Standard and all editions of the Hindi national daily newspaper Business Standard and Belgaum edition of Kannada daily newspaper Kannada Prabha (Kannada being the regional language in the state where our Company’s Registered Office is located), each with wide circulation, respectively, at least two Working Days prior to the Bid/ Offer Opening Date and shall be made available to the Stock Exchanges for the purpose of uploading on their website. The Price Band, along with the relevant financial ratios calculated at the Floor Price and at the Cap Price, shall be pre-filled in the Bid cum Application Forms available at the websites of the Stock Exchanges. The Offer Price shall be determined by our Company and the Investor Selling Shareholders, in consultation with the BRLM, after the Bid/Offer Closing Date, on the basis of assessment of market demand for the Equity Shares offered by way of Book Building Process. At any given point of time there shall be only one denomination for the Equity Shares.

## **Compliance with SEBI Rules and Regulations**

In connection with the Offer, Allotment and transfer of the Equity Shares in the Offer, the Company shall comply with applicable disclosures and accounting norms specified by SEBI from time to time.

## **Rights of the Equity Shareholders**

Subject to applicable laws, the equity shareholders of our Company shall have the following rights:

- the right to receive dividend, if declared;
- the right to attend general meetings and exercise voting powers, unless prohibited by law;
- the right to vote on a poll either in person or by proxy;
- the right to receive offers for rights shares and be allotted bonus shares, if announced;
- the right to receive surplus on liquidation subject to any statutory and other preferential claims being satisfied;
- the right of free transferability of Equity Shares, subject to applicable law, including RBI rules and regulations, if any; and
- such other rights, as may be available to a shareholder of a listed public company under the Companies Act the terms of the listing agreements executed with the Stock Exchanges, and the Memorandum and Articles of Association of our Company.

For a detailed description of the main provisions of the Articles of Association such as those dealing with voting rights, dividend, forfeiture and lien, transfer and transmission and / or consolidation / splitting, please refer to the chapter “*Main Provisions of the Articles of Association*” on page no. 347 of this Red Herring Prospectus.

## **Market Lot and Trading Lot**

Under Section 29 of the Companies Act, 2013, the Equity Shares shall be allotted only in dematerialized form for all investors.

In this context, two agreements have been signed among our Company, the respective Depositories and the Registrar to the Offer:

- Agreement dated April 23, 2019 among CDSL, our Company and the Registrar to the Offer; and
- Agreement dated December 28, 2017 among NSDL, our Company and the Registrar to the Offer

Since trading of the Equity Shares is in dematerialized mode, the tradable lot is one Equity Share. Allocation and allotment of Equity Shares through the Offer will be done only in electronic form, in multiple of one Equity Share, subject to a minimum allotment of [●] Equity Shares. For details of allocation and allotment, please refer to the chapter “*Offer Procedure*” on page no. 330 Red Herring Prospectus.

## **Joint Holders**

Subject to our Articles, where two or more persons are registered as the holders of any Equity Shares, they shall be deemed to hold the same as joint-tenants with benefits of survivorship.

## **Jurisdiction**

The courts of Mumbai, India will have exclusive jurisdiction in relation to this Offer.

## **Nomination facility to investors**

In accordance with Section 72 of the Companies Act, 2013 read with the Companies (Share Capital and Debenture) Rules, 2014, as amended, the sole or First Bidder, along with other joint Bidders, may nominate anyone person in



whom, in the event of the death of the sole Bidder or in case of joint Bidders, the death of all the Bidders, as the case may be, the Equity Shares Allotted, if any, shall vest to the exclusion of all other persons, unless the nomination is varied or cancelled in the prescribed manner. A person, being a nominee, entitled to the Equity Shares by reason of death of the original holder(s), shall be entitled to the same advantages to which such person would be entitled if such person were the registered holder of the Equity Share(s). Where the nominee is a minor, the holder(s) may make a nomination to appoint, in the prescribed manner, any person to become entitled to the Equity Share(s) in the event of his or her death during the minority. A nomination shall stand rescinded upon a sale or transfer of Equity Share(s) by the person nominating. A nomination may be cancelled or varied by nominating any other person in place of the present nominee by the holder of the Equity Shares who has made the nomination by giving a notice of such cancellation. A buyer will be entitled to make a fresh nomination in the manner prescribed. A fresh nomination can be made only on the prescribed form, which is available on request at our Registered Office or with the registrar and transfer agents of our Company.

Any person who becomes a nominee by virtue of Section 72 of the Companies Act, 2013 as mentioned above, shall, upon the production of such evidence as may be required by our Board, elect either:

- to register himself or herself as the holder of the Equity Shares; or
- to make such transfer of the Equity Shares, as the deceased holder could have made.

Further, the Board may at any time give notice requiring any nominee to choose either to be registered himself or herself or to transfer the Equity Shares, and if the notice is not complied with within a period of ninety days, the Board may thereafter withhold payment of all dividends, bonuses or other monies payable in respect of the Equity Shares, until the requirements of the notice have been complied with.

Since the allotment of Equity Shares in the Offer will be made only in dematerialized mode, there is no need to make a separate nomination with our Company. Nominations registered with respective depository participant of the applicant would prevail. If the investors require changing the nomination, they are requested to inform their respective depository participant.

#### Bid/Offer Program

Bid / Offer Opens On	September 30, 2019
Bid / Offer Closes On	October 04, 2019

An indicative timetable in respect of the offer is set out below:

Event	Indicative Date
Bid / Offer Closing Date	October 04, 2019
Finalisation of Basis of Allotment with the Designated Stock Exchange	on or before October 11, 2019
Initiation of Refunds / unblocking of funds from ASBA Account	on or before October 14, 2019
Credit of Equity Shares to demat account of the Allottees	on or before October 15, 2019
Commencement of trading of the Equity Shares on the Stock Exchanges	on or before October 16, 2019

The above timetable is indicative and does not constitute any obligation on our Company, Selling Shareholders or the BRLM. Whilst our Company shall ensure that all steps for the completion of the necessary formalities for the listing and the commencement of trading of the Equity Shares on the Stock Exchanges are taken within 6 Working Days of the Bid / Offer Closing Date, the timetable may change due to various factors, such as extension of the Bid / Offer Period by our Company and the Selling Shareholders, revision of the Price Band or any delay in receiving the final listing and trading approval from the Stock Exchanges. The commencement of trading of the Equity Shares will be entirely at the discretion of the Stock Exchanges and in accordance with the applicable laws. The Selling Shareholders confirm that it shall extend complete co-operation required by our Company and the BRLM for the completion of the necessary formalities for listing and commencement of trading of the Equity Shares at the Stock Exchanges within six Working Days from the Bid/Offer Closing Date.

Bids and any revision in Bids will be accepted only between 10.00 a.m. and 5.00 p.m. (Indian Standard Time) during the Bidding Period at the Bidding centers mentioned in the Bid-cum-Application Form or, in case of Bids submitted through ASBA, at the Designated Branches (a list of such branches is available at the website of the SEBI at <http://www.sebi.gov.in/sebiweb/home/list/5/33/0/0/Recognised-Intermediaries>) or with the members of the Syndicate at the Specified Locations or with the Registered Brokers at the Broker Centers (a list of such Broker Centers is available



at the websites of the Stock Exchanges), as the case may be. On the Bid/Offer Closing Date (which for QIBs will be a day prior to the Bid / Offer Closing Date for other non-QIB Bidders), Bids shall be accepted only between 10.00 a.m. and 3.00 p.m. (Indian Standard Time) and uploaded until (i) 4.00 p.m. in case of Bids by QIB Bidders and Non-Institutional Bidders; and until (ii) 5.00 p.m. or such extended time as may be permitted by the Stock Exchanges, in case of Bids by Retail Individual Bidders, after taking into account the total number of applications received up to the closure of timings and reported by BRLM to the Stock Exchanges. It is clarified that Bids not uploaded on the electronic bidding system would be rejected.

Due to limitation of time available for uploading the Bids on the Bid / Offer Closing Date, the Bidders other than QIB Bidders are advised to submit their Bids one day prior to the Bid/Offer Closing Date and, in any case, no later than 3.00 p.m. (Indian Standard Time) on the Bid / Offer Closing Date. Any time mentioned in this Red Herring Prospectus, unless specifically mentioned otherwise, is in Indian Standard Time. Bidders other than QIB Bidders are cautioned that in the event a large number of Bids are received on the Bid / Offer Closing Date, as is typically experienced in public offerings, which may lead to some Bids not being uploaded due to lack of sufficient time to upload, such Bids that cannot be uploaded will not be considered for allocation in the Offer. If such Bids are not uploaded, our Company and the Syndicate shall not be responsible. Bids will be accepted only on working days, i.e., Monday to Friday (excluding any public holiday). None among our Company, the Selling Shareholders or any member of the Syndicate is liable for any failure in (i) uploading the Bids due to faults in any software/ hardware system or otherwise, (ii) the blocking of Bid Amount in the ASBA Account on receipt of instructions from the Sponsor Bank on account of any errors, omissions or noncompliance by various parties involved in, or any other fault, malfunctioning or breakdown in, or otherwise, in the UPI Mechanism.

On the Bid / Offer Closing Date, extension of time will be granted by the Stock Exchanges only for uploading the Bids received by Retail Individual Bidders, after taking into account the total number of Bids received and reported by the BRLM to the Stock Exchanges within half an hour of such closure.

Our Company and the Selling Shareholders, in consultation with the BRLM, reserve the right to revise the Price Band during the Bidding Period in accordance with the SEBI ICDR Regulations. Under the SEBI ICDR Regulations, the Cap Price should not be more than 20% of the Floor Price i.e., the Cap Price shall be less than or equal to 120% of the Floor Price. Subject to compliance with the immediately preceding sentence, the revised Floor Price Band can move up or down to the extent of 20% of the Floor Price and the Cap Price will be revised accordingly.

**In case of revision in the Price Band, the Bid/Offer Period will be extended for at least three (3) additional Working Days after revision of the Price Band subject to the Bid / Offer Period not exceeding ten (10) Working Days. Any revision in the Price Band and the revised Bid / Offer Period, if applicable, will be widely disseminated by notification to the Stock Exchanges, by issuing a press release, and also by indicating the change on the websites of the BRLM at the terminals of the other members of the Syndicate.**

In case of discrepancy in the data entered in the electronic book *vis-à-vis* the data contained in the physical Bid cum Application Form, for a particular Bidder, the details as per the Bid file received from the Stock Exchanges may be taken as the final data for the purpose of Allotment. In case of discrepancy in the data entered in the electronic book *vis-à-vis* the data contained in the physical or electronic Bid cum Application Form, for a particular ASBA Bidder, the Registrar to the Offer shall ask the relevant SCSB or the member of the Syndicate for rectified data.

**It is clarified that Bids not uploaded on the electronic bidding system or in respect of which the full Bid Amount is not blocked by SCSBs would be rejected.**

### **Minimum Subscription**

In the event our Company does not receive (i) a minimum subscription of 90% of the Offer, and (ii) a subscription in the Offer equivalent to minimum number of securities as specified in Rule 19(2) of the SCRR, including through devolvement to the Underwriters, as applicable, our Company shall forthwith refund the entire subscription amount received no later than 15 days from the Bid / Offer Closing Date, failing which, the directors of our Company who are officers in default shall jointly and severally be liable to repay that money with interest at the rate of 15% per annum. If there is a delay beyond such period, our Company shall pay such interest prescribed under the Companies Act, 2013, read with the applicable rules framed thereunder. The Selling Shareholders shall reimburse to our Company, on a pro-rata basis, any expense incurred by our Company on their behalf with regard to refunds, interest for delays, etc., for the Equity Shares being offered in the Offer in proportion of the Equity Shares offered for sale pursuant to the Offer provided that subject to applicable law, a Selling Shareholder shall not be responsible to reimburse any interest unless such delay has been caused by such Selling Shareholder, in which case the Company shall be responsible for payment

of such interest. Our Company in consultation with the BRLM, reserve the right not to proceed with the Offer for any reason at any time after the Bid / Offer Opening Date but before the Allotment of Equity Shares. The requirement for minimum subscription is not applicable to the Offer for Sale.

In the event of an undersubscription in the Offer, Equity Shares offered pursuant to the Fresh Issue shall be allocated in the Offer, prior to the Equity Shares offered pursuant to the Offer for Sale. The Selling Shareholders agree and acknowledge that in the event that any Equity Shares are not sold in the Offer for Sale on account of under subscription, such unsold Equity Shares shall be subject to lock-in in accordance with this Red Herring Prospectus and the SEBI ICDR Regulations.

Further, in accordance with Regulation 26(4) of the SEBI ICDR Regulations, our Company shall ensure that the number of prospective allottees to whom the Equity Shares will be Allotted will be not less than 1,000.

#### **Arrangement for disposal of odd lot**

Since our Equity Shares will be traded in dematerialised form only and the market lot for our Equity Shares will be one Equity Share, no arrangements for disposal of odd lots are required.

#### **Restriction on transfer and transmission of shares**

Except for lock-in of pre-Offer equity shareholding and Promoters' Contribution lock-in in the Offer and except as provided in our Articles and under applicable laws, there are no restrictions on transfers and transmission of Equity Shares or on their consolidation or splitting. For details please see the chapters "*Capital Structure*" and "*Main Provisions of the Articles of Association*" on page nos. 69 and 347 of this Red Herring Prospectus respectively.

#### **New Financial Instruments**

As on the date of this Red Herring Prospectus, there are no outstanding warrants, new financial instruments or any rights, which would entitle the shareholders of our Company, including our Promoter, to acquire or receive any Equity Shares after the Offer.

#### **Withdrawal of the Offer**

Our Company and the Selling Shareholders in consultation with the BRLM, reserves the right not to proceed with the Offer anytime after the Bid / Offer Opening Date but before the Allotment. In such an event, our Company would issue a public notice in the same newspapers, in which the pre-offer advertisements were published, within two days of the Bid / Offer Closing Date, providing reasons for not proceeding with the Offer and the Stock Exchanges shall be informed promptly in this regard. The BRLM, through the Registrar to the Offer, shall notify the SCSBs to unblock the Bank Accounts of the ASBA Bidders within one Working Day from the date of receipt of such notification.

If our Company withdraws the Offer after the Bid / Offer Closing Date and thereafter determine that they will proceed with an initial public offering of the Company's Equity Shares, the Company shall file a fresh Draft Red Herring Prospectus with SEBI. Notwithstanding the foregoing, the Offer is also subject to obtaining (i) the final listing and trading approvals of the Stock Exchanges, which the Company shall apply for after Allotment, and (ii) the final RoC approval of the Prospectus after it is filed with the RoC.

#### **Option to Receive Securities in Dematerialized Form**

Pursuant to Section 29 of the Companies Act, 2013, the Equity Shares in the Issue shall be allotted only in dematerialized form. Further, as per the SEBI ICDR Regulations, the trading of the Equity Shares shall only be in dematerialised form on the Stock Exchanges.

## OFFER STRUCTURE

Public Offer of upto 1,00,00,000 Equity Shares for cash at price of ₹ [●] (including a share premium of ₹ [●] per Equity Share) aggregating to ₹ [●] lakhs comprising of a Fresh Offer of upto 30,00,000 Equity Shares aggregating to ₹ [●] lakhs by our Company and an Offer of Sale of upto 70,00,000 Equity Shares aggregating to ₹ [●] lakhs by the Selling shareholders. The Offer will constitute 26.63% of the post – Offer paid-up Equity Share capital of our Company.

*The Offer is being made through the Book Building Process:*

Particulars	QIBs	Non-Institutional Bidders	Retail Individual Bidders
Number of Equity Shares available for Allotment / allocation <sup>(1)</sup>	Not more than 10,00,000 Equity Shares or Offer less allocation to Non- Institutional Bidders and Retail Individual Bidders	Not less than 40,00,000 Equity Shares available for allocation or Offer less allocation to QIBs Bidders and Retail Individual Bidders	Not less than 50,00,000 Equity Shares available for allocation or Offer less allocation to QIBs Bidders and Non- Institutional Bidders
Percentage of Offer size available for Allotment / allocation	Not more than 10% of the Offer Size shall be available for allocation to QIBs.  However, upto 5% of the QIB Portion shall be available for allocation proportionately to Mutual Funds only. Mutual Funds participating in the 5% reservation in the QIB Portion will also be eligible for allocation in the remaining QIB Portion. The unsubscribed portion in the Mutual Fund reservation will be available for allocation to QIBs.	Not less than 40% of the Offer or Offer less allocation to QIBs Bidders and Retail Individual Bidders	Not less than 50% of the Offer or Offer less allocation to QIBs Bidders and Non- Institutional Bidders
Basis of Allotment if respective category is oversubscribed	Proportionate as follows: a) Upto 50,000 Equity Shares shall be available for allocation on a proportionate basis to Mutual Funds only; and b) Upto 9,50,000 Equity Shares shall be allotted on a proportionate basis to all QIBs, including Mutual Funds receiving allocation as per (a) above.	Proportionate.	Allotment to each Retail Individual Bidders shall not be less than the minimum Bid Lot, subject to availability of Equity Shares in the Retail Portion, and the remaining available Equity Shares, if any, shall be Allotted on a proportionate basis. For further details, see “Allotment Procedure and Basis of Allotment – Allotment to RIBs” in the GID
Minimum Bid	Such number of Equity Shares in multiples of [●] Equity Shares so that the Bid Amount exceeds ₹ 200,000.	Such number of Equity Shares in multiples of [●] Equity Shares so that the Bid Amount exceeds ₹ 200,000.	[●] Equity Shares.
Maximum Bid	Such number of Equity Shares in multiples of [●] Equity Shares so that the Bid does not exceeds the size of the Offer, subject to applicable limits to the Bidder.	Such number of Equity Shares in multiples of [●] Equity Shares so that the Bid does not exceeds the size of the Offer, subject to applicable limits to the Bidder.	Such number of Equity Shares in multiples of [●] Equity Shares so that the Bid Amount does not exceed ₹ 200,000.
Mode of Allotment	Compulsorily in dematerialised form.		
Bid Lot	[●] Equity Shares and in multiples of [●] Equity Shares thereafter.		

Allotment Lot	A minimum of [●] Equity Shares and thereafter in multiples of [●] Equity Share.	A minimum of [●] Equity Shares and thereafter in multiples of [●] Equity Share.	A minimum of [●] Equity Shares and thereafter in multiples of [●] Equity Share, subject to availability in the Retail Portion.
Trading Lot	One Equity Share.		
Who can Apply <sup>(2)</sup>	Mutual Funds, Venture Capital Funds, AIFs, FPIs (other than Category III FPIs) public financial institution as defined in Section 2(72) of the Companies Act, 2013, a scheduled commercial bank, NBFC-SI, state industrial development corporation, insurance company registered with the Insurance Regulatory and Development Authority, provident fund with minimum corpus of ₹ 2,500 lakhs, pension fund with minimum corpus of ₹ 2,500 lakhs, National Investment Fund, insurance funds set up and managed by army, navy or air force of the Union of India and insurance funds set up and managed by the Department of Posts, India.	Eligible NRIs, Resident Indian individuals, HUFs (in the name of the Karta), companies, corporate bodies, scientific institutions, societies and trusts, sub-accounts of FIIs registered with SEBI, which are foreign corporates or foreign individuals and Category III FPIs.	Resident Indian individuals, HUFs (in the name of the Karta) and Eligible NRIs.
Terms of Payment <sup>(3)</sup>	Full Bid Amount shall be payable at the time of submission of the Bid cum Application Form.		
Mode of Bidding	Only through the ASBA process.		

<sup>(1)</sup> Applicants Subject to valid Bids being received at or above the Offer Price. In terms of Rule 19(2)(b)(i) of the SCRR, this is an Offer for atleast 25% of the post- offer paid-up equity share capital of our Company. The Offer is being made through the Book Building Process, in compliance with the SEBI ICDR Regulations, wherein not more than 10% of the Offer shall be available for allocation on a proportionate basis to QIBs, 5% of the QIB Category shall be available for allocation on a proportionate basis to Mutual Funds only, and the remainder of the QIB Category shall be available for allocation on a proportionate basis to all QIB Bidders including Mutual Funds, subject to valid Bids being received at or above the Offer Price. Further, not less than 40% of the Offer shall be available for allocation on a proportionate basis to Non-Institutional Bidders and not less than 50% of the Offer shall be available for allocation to Retail Individual Bidders in accordance with the SEBI Regulations, subject to valid Bids being received at or above the Offer Price.

Subject to valid Bids being received at or above the Offer Price, under-subscription, if any, in the Non-Institutional Portion or the Retail Portion would be allowed to be met with spill-over from other categories or a combination of categories at the discretion of our Company and the Selling Shareholders, in consultation with the BRLM and the Designated Stock Exchange, on a proportionate basis. However, under-subscription, if any, in the QIB Portion will not be allowed to be met with spill-over from other categories or a combination of categories.

<sup>(2)</sup> In case of joint Bids, the Bid cum Application Form should contain only the name of the first Bidder whose name should also appear as the first holder of the beneficiary account held in joint names. The signature of only such first Bidder would be required in the Bid cum Application Form and such first Bidder would be deemed to have signed on behalf of the joint holders.

<sup>(3)</sup> In case of ASBA Bidders, the SCSB shall be authorised to block such funds in the bank account of the ASBA Bidder that are specified in the Bid cum Application Form.

## OFFER PROCEDURE

All Bidders should review the 'General Information Document for investing in Public Issues prepared and issued in accordance with the circular (CIR/CFD/DIL/12/2013) dated October 23, 2013 notified by SEBI and updated pursuant to among others the circular (CIR/CFD/POLICYCELL/11/2015) dated November 10, 2015 as amended and modified by the circular (CIR/CFD/DIL/1/2016) dated January 1, 2016 and the circular (SEBI/HO/CFD/DIL/CIR/P/2016/26) dated January 21, 2016, notified by SEBI ("**General Information Document**"), which highlights the key rules, processes and procedures applicable to public Offers in general in accordance with the provisions of the Companies Act, the SCRA, the SCRR and the SEBI ICDR Regulations for all the Draft Red Herring Prospectus filed prior to November 10, 2018, to the extent applicable and the SEBI ICDR Regulations 2018. The General Information Document has been updated to reflect various amendments to the SEBI ICDR Regulations and provisions of the Companies Act, 2013, to the extent applicable to a public issue and any other enactments and regulations to the extent applicable to the Offer. The General Information Document is also available on the websites of the Stock Exchanges and the BRLM. Please refer to the relevant portions of the General Information Document which are applicable to this Offer especially in relation to the process for Bids by RIIs through the UPI mechanism. The investors should note that the details and process provided in the GID should be read along with this section.. All Designated Intermediaries in relation to the Offer should ensure compliance with the SEBI circular (CIR/CFD/POLICYCELL/11/2015) dated November 10, 2015, as amended and modified by the circular (SEBI/HO/CFD/DIL/CIR/P/2016/26) dated January 21, 2016, circular (SEBI/HO/CFD/DIL2/CIR/P/2018/22) dated February 15, 2018 and circular (SEBI/HO/CFD/DIL2/CIR/P/2018/138) dated November 1, 2018 as amended from time to time, including pursuant to circular (SEBI/HO/CFD/DIL2/CIR/P/2019/50) dated April 3, 2019, each notified by SEBI, in relation to clarifications on streamlining the process of public issue of equity shares and convertibles.

SEBI through its circular no. SEBI/HO/CFD/DIL2/CIR/P/2018/138 dated November 1, 2018 as amended from time to time, including pursuant to circular (SEBI/HO/CFD/DIL2/CIR/P/2019/50) dated April 3, 2019, circular no. SEBI/HO/CFD/DIL2/CIR/P/2019/76 dated June 28, 2019 and circular no. SEBI/HO/CFD/DIL2/CIR/P/2019/85 dated July 26, 2019 ("**UPI Circular**") has introduced an alternate payment mechanism using Unified Payments Interface ("**UPI**") and consequent reduction in timelines for listing in a phased manner. From January 1, 2019, the UPI mechanism for RIIs applying through Designated Intermediaries will be made effective along with the existing process and existing timeline of T+6 days. The same will continue for a period of three months or launch of five main board public issues, whichever is later ("**UPI Phase I**"). Thereafter, for application by RIIs through Designated Intermediaries, the existing process of physical movement of forms from Designated Intermediaries to SCSBs for blocking of funds will be discontinued and only the UPI mechanism with existing timeline of T+6 days will continue for a period of three months or launch of five main board public issues, whichever is later ("**UPI Phase II**"). Subsequently, the final reduced timeline will be made effective using the UPI mechanism for applications by RIIs ("**UPI Phase III**"), as may be prescribed by SEBI.

**The procedure set forth in this section is based on the assumption that the Offer will be under UPI Phase II. However, if the Bid/ Offer Opening Date falls after UPI Phase III becomes applicable in accordance with any circulars issued by SEBI from time to time, the Offer will be undertaken in accordance with the framework made applicable by SEBI through such circulars, including, among others, bid by Retail Individual Investors through Designated Intermediaries using the UPI Mechanism.**

Our Company, the Selling Shareholders and the Syndicate do not accept any responsibility for the completeness and accuracy of the information stated in this section and the General Information Document for any amendment, modification or change in the applicable law which may occur after the date of this Red Herring Prospectus. Bidders are advised to make their independent investigations and ensure that their Bids are submitted in accordance with applicable laws and do not exceed the investment limits or maximum number of Equity Shares that can be held by them under applicable law or as specified in this Red Herring Prospectus, the Red Herring Prospectus and the Prospectus.

### Book Building Procedure

The Offer is being made through the Book Building Process, in compliance with Regulation 26(1) of the SEBI ICDR Regulations, wherein where in not more than 10% of the Offer shall be allocated on a proportionate basis to Qualified Institutional Buyers ("**QIBs**") ("**QIB Portion**"), 5% of the QIB Portion shall be available for allocation on a proportionate basis to Mutual Funds only, and the remainder of the QIB Portion shall be available for allocation on a proportionate basis to all QIB Bidders, including Mutual Funds, subject to valid Bids being received at or above the Offer Price. Further, not less than 40% of the Offer shall be available for allocation on a proportionate basis to Non-Institutional Bidders and not less than 50% of the Offer shall be available for allocation to Retail Individual Bidders in accordance with the SEBI ICDR Regulations, subject to valid Bids being received at or above the Offer Price. All



potential investors are required to mandatorily use the Application Supported by Blocked. Amount (“ASBA”) process providing details of the irrespective bank accounts which will be blocked by the Self Certified Syndicate Banks (“SCSBs”).

Under-subscription, if any, in any category, except in the QIB Category, would be allowed to be met with spill over from any other category or combination of categories, at the discretion of our Company and the Selling Shareholders in consultation with the BRLM and the Designated Stock Exchange, subject to applicable laws.

The Equity Shares, on Allotment, shall be traded only in the dematerialized segment of the Stock Exchanges.

**Investors should note that according to section 29(1) of the Companies Act, 2013, allotment of Equity Shares to all successful Bidders will only be in the dematerialised form. The Bid cum Application Forms which do not have the details of the Bidder’s depository account including DP ID, PAN and Beneficiary Account Number, UPI ID, as applicable, shall be treated as incomplete and rejected. In case DP ID, Client ID and PAN mentioned in the Bid cum Application Form and entered into the electronic system of the stock exchanges, do not match with the DP ID, Client ID and PAN available in the depository database, the bid is liable to be rejected. Bidders will not have the option of getting allotment of the Equity Shares in physical form. The Equity Shares on allotment shall be traded only in the dematerialised segment of the Stock Exchanges.**

#### **Phased implementation of UPI for Bids by Retail Individual Bidders as per the UPI Circular**

SEBI has issued a circular bearing number SEBI/HO/CFD/DIL2/CIR/P/2018/138 dated November 1, 2018 and circular no. SEBI/HO/CFD/DIL2/CIR/P/2019/50 dated April 3, 2019, circular no. SEBI/HO/CFD/DIL2/CIR/P/2019/76 dated June 28, 2019 and circular no. SEBI/HO/CFD/DIL2/CIR/P/2019/85 dated July 26, 2019 (collectively the “**UPI Circular**”) in relation to streamlining the process of public issue of equity shares and convertibles. Pursuant to the UPI Circular, UPI will be introduced in a phased manner as a payment mechanism (in addition to mechanism of blocking funds in the account maintained with SCSBs under the ASBA) for applications by RIIs through intermediaries with the objective to reduce the time duration from public issue closure to listing from six Working Days to up to three Working Days. Considering the time required for making necessary changes to the systems and to ensure complete and smooth transition to the UPI Mechanism, the UPI Circular proposes to introduce and implement the UPI Mechanism in three phases in the following manner:

- a) **Phase I:** This phase has become applicable from January 1, 2019 and will continue till June 30, 2019. Under this phase, a Retail Individual Bidder would also have the option to submit the Bid cum Application Form with any of the intermediary and use his / her UPI ID for the purpose of blocking of funds. The time duration from public issue closure to listing would continue to be six Working Days.
- b) **Phase II:** This phase will commence upon completion of Phase I and will continue for a period of three months or floating of five main board public issues, whichever is later. Under this phase, submission of the Bid cum Application Form by a Retail Individual Bidder through intermediaries to SCSBs for blocking of funds will be discontinued and will be replaced by the UPI Mechanism. However, the time duration from public issue closure to listing would continue to be six Working Days during this phase.
- c) **Phase III:** Subsequently, the time duration from public issue closure to listing would be reduced to be three Working Days.

All SCSBs offering facility of making application in public issues shall also provide facility to make application using the UPI Mechanism. The issuers are to appoint one of the SCSBs as a sponsor bank to act as a conduit between the Stock Exchanges and NPCI in order to facilitate collection of requests and / or payment instructions of the Retail Individual Bidders into the UPI mechanism.

For further details, refer to the General Information Document available on the websites of the Stock Exchanges and the Book Running Lead Manager.

#### **Bid cum Application Form**

Copies of the ASBA Form and the abridged prospectus will be available with the Designated Intermediaries at the Bidding Centers and Registered and Corporate Office of our Company. An electronic copy of the ASBA Form will also be available for download on the websites of SCSBs, NSE ([www.nseindia.com](http://www.nseindia.com)) and BSE ([www.bseindia.com](http://www.bseindia.com)) and the terminals of Non-Syndicate Registered Brokers at least one day prior to the Bid/Offer Opening Date.



All Bidders shall mandatorily participate in the Offer only through the ASBA process.

Bidders (other than RIIs bidding using the UPI mechanism) must provide bank account details and authorisation by the ASBA account holder to block funds in their respective ASBA Accounts in the relevant space provided in the Bid cum Application Form and the Bid cum Application Form that does not contain such detail are liable to be rejected.

RIIs bidding using the UPI mechanism must provide the UPI ID in the relevant space provided in the Bid cum Application Form and the Bid cum Application Form that does not contain the UPI ID are liable to be rejected.

ASBA Bidders must provide bank account details or the UPI ID, as applicable, in the relevant space provided in the ASBA Form and authorisation to block funds in their respective ASBA Accounts in the relevant space provided in the ASBA Form and the ASBA Forms that do not contain such details are liable to be rejected.

ASBA Bidders shall ensure that the Bids are made on ASBA Forms bearing the stamp of the Designated Intermediary, submitted at the Bidding Centres only (except in case of electronic ASBA Forms) and the ASBA Forms not bearing such specified stamp are liable to be rejected. RIIs using UPI Mechanism, may submit their ASBA Forms, including details of their UPI IDs, with the Syndicate, Sub-Syndicate members, Registered Brokers, CRTAs or CDPs. RIIs authorising an SCSB to block the Bid Amount in the ASBA Account may submit their ASBA Forms with the SCSBs. ASBA Bidders must ensure that the ASBA Account has sufficient credit balance such that an amount equivalent to the full Bid Amount can be blocked by the SCSB at the time of submitting the Bid.

The prescribed colour of the Bid Cum Application Form for various categories is as follows:

Category	Colour <sup>(1)</sup>
Resident Indians and Eligible NRIs applying on a non-repatriation basis	White
Non-Residents and Eligible NRIs, FIIs, FVCIs, etc. applying on a repatriation basis	Blue

<sup>(1)</sup> excluding electronic Bid cum Application Form

In case of ASBA Forms, Designated Intermediaries shall upload the relevant bid details in the electronic bidding system of the Stock Exchanges. Subsequently, for ASBA Forms (other than RIIs using UPI mechanism) Designated Intermediaries (other than SCSBs) shall submit/deliver the Bid cum Application Form (except the Bid cum Application Form from a RIIs using the UPI mechanism) to the respective SCSB, where the Bidder has a bank account and shall not submit it to any non-SCSB bank or any Escrow Bank. For RIIs using UPI mechanism, the Stock Exchanges shall share the bid details (including UPI ID) with the Sponsor Bank on a continuous basis to enable the Sponsor Bank to initiate UPI Mandate Request to RIIs for blocking of funds.

### Who can Bid?

In addition to the category of Bidders set forth in the *General Information Document*, the following persons are also eligible to invest in the Equity Shares under all applicable laws, regulations and guidelines:

- Scientific and/or industrial research organizations in India, which are authorised to invest in equity shares; and
- Any other person eligible to Bid in this Offer, under the laws, rules, regulations, guidelines and polices applicable to them.

**The Equity Shares have not been and will not be registered under the U.S. Securities Act of 1933, as amended (the “U.S. Securities Act”) or any state securities laws in the United States and may not be offered or sold within the United States or to, or for the account or benefit of, U.S. persons (as defined in Regulation S) except pursuant to an exemption from, or in a transaction not subject to, the registration requirements of the U.S. Securities Act and applicable state securities laws in the United States. Accordingly, the Equity Shares are being offered and sold outside the United States in offshore transactions in compliance with Regulation S under the U.S. Securities Act and the applicable laws of the jurisdiction where those offers and sales occur.**

**The Equity Shares have not been and will not be registered, listed or otherwise qualified in any other jurisdiction outside India and may not be offered or sold, and Bids may not be made by persons in any such jurisdiction, except in compliance with the applicable laws of such jurisdiction.**

**Participation by Promoter, Promoter Group, the BRLM, the Syndicate Members and persons related to the Promoter/Promoter Group/BRLM**

The BRLM and the Syndicate Members shall not be allowed to subscribe to the Equity Shares in this Offer in any manner, except towards fulfilling their underwriting obligations. However, associates and affiliates of the BRLM and the Syndicate Members may subscribe to or purchase Equity Shares in the Offer, in the QIB Portion or in Non-Institutional Portion as may be applicable to such Bidders. Such Bidding and subscription may be on their own account or on behalf of their clients. All categories of investors, including associates or affiliates of the BRLM and Syndicate Members, shall be treated equally for the purpose of allocation to be made on a proportionate basis.

For the purposes of this section, a QIB who has any of the following rights shall be deemed to be a “person related to the Promoters or Promoter Group”: (a) rights under a shareholders’ agreement or voting agreement entered into with the Promoters or members of the Promoter Group; (b) veto rights; or (c) right to appoint any nominee director on our Board.

The Selling Shareholders, Promoters and the Members of the Promoter Group will not participate in the Offer except to the extent of the Offered Shares.

### **Bids by Mutual Funds**

Bids made by asset management companies or custodians of Mutual Funds shall specifically state names of the concerned schemes for which such Bids are made. In case of a Mutual Fund, a separate Bid can be made in respect of each scheme of the Mutual Fund registered with SEBI and such Bids in respect of more than one scheme of the Mutual Fund will not be treated as multiple Bids provided that the Bids clearly indicate the scheme concerned for which the Bid has been made.

With respect to Bids by Mutual Funds, a certified copy of their SEBI registration certificate must be lodged with the Bid cum Application Form. Failing this, our Company and the Selling Shareholders reserves the right to reject any Bid in whole or in part, in either case, without assigning any reason thereof.

No Mutual Fund scheme shall invest more than 10% of its net asset value in the equity shares or equity related instruments of any single company provided that the limit of 10% shall not be applicable for investments in index funds or sector or industry specific funds. No Mutual Fund under all its schemes should own more than 10% of any company’s paid-up share capital carrying voting rights.

### **Bids by Eligible NRIs**

Eligible NRIs may obtain copies of Bid cum Application Form from the Designated Intermediaries. Eligible NRI Bidders bidding on a repatriation basis by using the Non-Resident Forms should authorize their SCSB to block their Non-Resident External (“NRE”) accounts, or Foreign Currency Non-Resident (“FCNR”) ASBA Accounts, and eligible NRI Bidders bidding on a non-repatriation basis by using Resident Forms should authorize their SCSB to block their Non-Resident Ordinary (“NRO”) accounts for the full Bid Amount, at the time of the submission of the Bid cum Application Form.

Eligible NRIs Bidding on a repatriation basis are advised to use the Bid cum Application Form meant for Non-Residents (blue in colour).

Eligible NRIs Bidding on non-repatriation basis are advised to use the Bid cum Application Form for residents. (white in colour).

Pursuant to the provisions of the FEMA regulations, investments by NRIs under the Portfolio Investment Scheme (“PIS”) is subject to certain limits, i.e., 10.00% of the paid-up equity share capital of the company. Such limit for NRI investment under the PIS route can be increased by passing a board resolution, followed by a special resolution by the shareholders, subject to prior intimation to the RBI. Our Company has not passed any resolution to increase this limit.

### **Bids by FPI and FIIs**

In terms of the SEBI FPI Regulations, any qualified foreign investor or FII who holds a valid certificate of registration from SEBI shall be deemed to be an FPI until the expiry of the block of three years for which fees have been paid as per the SEBI FII Regulations. An FII or a sub-account may participate in this Offer, in accordance with Schedule 2 of the FEMA Regulations, until the expiry of its registration with SEBI as an FII or a sub-account. An FII shall not be eligible to invest as an FII after registering as an FPI under the SEBI FPI Regulations.

In case of Bids made by FPIs, a certified copy of the certificate of registration issued by the designated depository participant under the FPI Regulations is required to be attached to the Bid cum Application Form, failing which our Company reserves the right to reject any Bid without assigning any reason. An FII or subaccount may, subject to payment of conversion fees under the SEBI FPI Regulations, participate in the Offer, until the expiry of its registration as a FII or sub-account, or until it obtains a certificate of registration as FPI, whichever is earlier. Further, in case of Bids made by SEBI-registered FIIs or sub-accounts, which are not registered as FPIs, a certified copy of the certificate of registration as an FII issued by SEBI is required to be attached to the Bid cum Application Form, failing which our Company reserves the right to reject any Bid without assigning any reason.

In terms of the SEBI FPI Regulations, the Offer of Equity Shares to a single FPI or an investor group (which means the same set of ultimate beneficial owner(s) investing through multiple entities) must be below 10.00% of our post-Offer Equity Share capital. Further, in terms of the FEMA Regulations, the total holding by each FPI shall be below 10.00% of the total paid-up Equity Share capital of our Company and the total holdings of all FPIs put together shall not exceed 24% of the paid-up Equity Share capital of our Company. The aggregate limit of 24% may be increased up to the sectorial cap by way of a resolution passed by the Board of Directors followed by a special resolution passed by the Shareholders of our Company and subject to prior intimation to RBI. In terms of the FEMA Regulations, for calculating the aggregate holding of FPIs in a company, holding of all registered FPIs as well as holding of FIIs (being deemed FPIs) shall be included. The existing individual and aggregate investment limits an FII or sub account in our Company is 10.00% and 24% of the total paid-up Equity Share capital of our Company, respectively.

FPIs are permitted to participate in the Offer subject to compliance with conditions and restrictions which may be specified by the Government from time to time.

Subject to compliance with all applicable Indian laws, rules, regulations, guidelines and approvals in terms of Regulation 22 of the SEBI FPI Regulations, an FPI, other than Category III foreign portfolio and unregulated broad based funds, which are classified as Category II foreign portfolio investor by virtue of their investment manager being appropriately regulated, may Offer or otherwise deal in offshore derivative instruments (as defined under the SEBI FPI Regulations as any instrument, by whatever name called, which is issued overseas by an FPI against securities held by it that are listed or proposed to be listed on any recognized stock exchange in India, as its underlying) directly or indirectly, only in the event (i) such offshore derivative instruments are issued only to persons who are regulated by an appropriate regulatory authority; and (ii) such offshore derivative instruments are issued after compliance with know your client' norms. An FPI is also required to ensure that no further Offer or transfer of any offshore derivative instrument is made by or on behalf of it to any persons that are not regulated by an appropriate foreign regulatory authority.

FPIs who wish to participate in the Offer are advised to use the Bid cum Application Form for Non-Residents (blue in colour).

#### **Bids by SEBI registered VCFs, AIFs and FVCIs**

The SEBI FVCI Regulations and the SEBI AIF Regulations inter-alia prescribe the investment restrictions on the VCFs, FVCIs and AIFs registered with SEBI. Further, the SEBI AIF Regulations prescribe, among others, the investment restrictions on AIFs.

The holding by any individual VCF registered with SEBI in one venture capital undertaking should not exceed 25% of the corpus of the VCF. Further, VCFs and FVCIs can invest only up to 33.33% of the investible funds by way of subscription to an initial public offering.

The category I and II AIFs cannot invest more than 25% of the corpus in one Investee Company. A category III AIF cannot invest more than 10% of the corpus in one Investee Company. A venture capital fund registered as a category I AIF, as defined in the SEBI AIF Regulations, cannot invest more than 1/3rd of its corpus by way of subscription to an initial public offering of a venture capital undertaking. Additionally, the VCFs which have not re-registered as an AIF under the SEBI AIF Regulations shall continue to be regulated by the VCF Regulation until the existing fund or scheme managed by the fund is wound up and such funds shall not launch any new scheme after the notification of the SEBI AIF Regulations.

All FIIs and FVCIs should note that refunds, dividends and other distributions, if any, will be payable in Indian Rupees only and net of Bank charges and commission.

**Our Company or the Selling Shareholders or the BRLM will not be responsible for loss, if any, incurred by the Bidder on account of conversion of foreign currency.**

**There is no reservation for Eligible NRIs, FPIs and FVCIs and all Bidders will be treated on the same basis with other categories for the purpose of allocation.**

#### **Bids by Limited Liability Partnerships**

In case of Bids made by limited liability partnerships registered under the Limited Liability Partnership Act, 2008, a certified copy of certificate of registration issued under the Limited Liability Partnership Act, 2008, must be attached to the Bid cum Application Form. Failing this, our Company and the Selling Shareholders reserve the right to reject any Bid without assigning any reason thereof.

#### **Bids by Insurance Companies**

In case of Bids made by insurance companies registered with the IRDA, a certified copy of certificate of registration issued by IRDA must be attached to the Bid cum Application Form. Failing this, our Company and the Selling Shareholders reserves the right to reject any Bid without assigning any reason thereof.

The exposure norms for insurers prescribed in Regulation 9 of the Insurance Regulatory and Development Authority of India (Investment) Regulations, 2016 (“IRDAI Investment Regulations”) are set forth below:

- a. equity shares of a company: the lower of 10%<sup>(1)</sup> of the investee company’s outstanding equity shares (face value) or 10% of the respective fund in case of a life insurer/investment assets in case of a general insurer or a reinsurer;
- b. the entire group of the investee company: not more than 15% of the respective fund in case of a life insurer or 15% of investment assets in case of a general insurer or a reinsurer or 15% of the investment assets in all companies belonging to the group, whichever is lower; and
- c. the industry sector in which the investee company operates: not more than 15% of the respective fund of a life insurer or general insurance or 15% of the investment assets, whichever is lower.

The maximum exposure limit, in the case of an investment in equity shares, cannot exceed the lower of an amount of 10% of the investment assets of a life insurer or general insurer and the amount calculated under points (i), (ii) or (iii) above, as the case may be.

*<sup>(1)</sup> The above limit of 10% shall stand substituted as 15% of outstanding equity shares (face value) for insurance companies with investment assets of ₹ 2,500,000 million or more and 12% of outstanding equity shares (face value) for insurers with investment assets of ₹ 500,000 million or more but less than ₹ 2,500,000 million.*

Insurer companies participating in this Offer shall comply with all applicable regulations, guidelines and circulars issued by the IRDA from time to time including the Insurance Regulatory and Development Authority (Investment) Regulations, 2016 (“**IRDA Investment Regulations**”).

#### **Bids by provident funds/ pension funds**

In case of Bids made by provident funds / pension funds, subject to applicable laws, with minimum corpus of ₹ 2,500 lacs, a certified copy of a certificate from a chartered accountant certifying the corpus of the provident fund / pension fund must be attached to the Bid cum Application Form. Failing this, our Company and the Selling Shareholders reserves the right to reject any Bid, without assigning any reason thereof.

#### **Bids by Systemically Important Non-Banking Financial Companies**

In case of Bids made by systemically important non-banking financial companies, a certified copy of the certificate of registration issued by the RBI, a certified copy of its last audited financial statements on a standalone basis and a net worth certificate from its statutory auditor(s), must be attached to the Bid cum Application Form. Failing this, our Company reserves the right to reject any Bid, without assigning any reason thereof. Systemically Important Non Banking Financial Companies participating in the Offer shall comply with all applicable regulations, guidelines and circulars issued by RBI from time to time.

### **Bids by banking companies**

In case of Bids made by banking companies registered with RBI, certified copies of: (i) the certificate of registration issued by RBI, and (ii) the approval of such banking company's investment committee are required to be attached to the Bid cum Application Form, failing which our Company and the Selling Shareholders reserves the right to reject any Bid without assigning any reason.

The investment limit for banking companies in non-financial services companies as per the Banking Regulation Act, 1949, as amended ("Banking Regulation Act"), and the Master Direction – Reserve Bank of India (Financial Services provided by Banks) Directions, 2016, is 10.00% of the paid-up share capital of the investee company or 10.00% of the banks' own paid-up share capital and reserves, whichever is less. Further, the aggregate investment by a banking company in subsidiaries and other entities engaged in financial and non-financial services company cannot exceed 20.00% of the bank's paid-up share capital and reserves. A banking company may hold up to 30.00% of the paid-up share capital of the investee company with the prior approval of the RBI provided that the investee company is engaged in non-financial activities in which banking companies are permitted to engage under the Banking Regulation Act.

### **Bids by SCSBs**

SCSBs participating in the Offer are required to comply with the terms of the SEBI circulars dated September 13, 2012 and January 2, 2013. Such SCSBs are required to ensure that for making applications on their own account using ASBA, they should have a separate account in their own name with any other SEBI registered SCSBs. Further, such account shall be used solely for the purpose of making application in public Offers and clear demarcated funds should be available in such account for such applications.

### **Bids under Power of Attorney**

In case of Bids made pursuant to a power of attorney or by limited companies, corporate bodies, registered societies, FIIs, Mutual Funds, insurance companies and provident funds with a minimum corpus of ₹ 250 million (subject to applicable law) and pension funds with a minimum corpus of ₹ 250 million, a certified copy of the power of attorney or the relevant resolution or authority, as the case may be, along with a certified copy of the memorandum of association and articles of association and/or bye laws must be lodged along with the Bid cum Application Form. Failing this, our Company and the Selling Shareholders reserves the right to accept or reject any Bid in whole or in part, in either case, without assigning any reasons thereof. In addition to the above, certain additional documents are required to be submitted by the following entities:

- a) With respect to Bids by FIIs and Mutual Funds, a certified copy of their SEBI registration certificate must be lodged along with the Bid cum Application Form.
- b) With respect to Bids by insurance companies registered with the Insurance Regulatory and Development Authority, in addition to the above, a certified copy of the certificate of registration issued by the Insurance Regulatory and Development Authority must be lodged along with the Bid cum Application Form.
- c) With respect to Bids made by provident funds with a minimum corpus of ₹ 250 million (subject to applicable law) and pension funds with a minimum corpus of ₹ 250 million, a certified copy of a certificate from a chartered accountant certifying the corpus of the provident fund/pension fund must be lodged along with the Bid cum Application Form.
- d) With respect to Bids made by limited liability partnerships registered under the Limited Liability Partnership Act, 2008, a certified copy of certificate of registration issued under the Limited Liability Partnership Act, 2008, must be attached to the Bid cum Application Form.
- e) Our Company in its absolute discretion, reserves the right to relax the above condition of simultaneous lodging of the power of attorney along with the Bid cum Application form, subject to such terms and conditions that our Company and the BRLM may deem fit.

**The above information is given for the benefit of the Bidders. Our Company, the Selling Shareholder, the Book Running Lead Manager and the Syndicate Members are not liable for any amendments or modification or changes in applicable laws or regulations, which may occur after the date of the Red Herring Prospectus. Bidders are advised to make their independent investigations and Bidders are advised to ensure that any single**



**Bid from them does not exceed the applicable investment limits or maximum number of Equity Shares that can be held by them under applicable law or regulation or as specified in the Red Herring Prospectus.**

### **Pre- Offer Advertisement**

Subject to Section 30 of the Companies Act, 2013, our Company shall, after registering the Red Herring Prospectus with the RoC, publish a pre-Offer advertisement in all editions of the English national daily newspaper Business Standard, all editions of the Hindi national daily newspaper Business Standard and the Belgaum edition of the Kannada newspaper Kannada Prabha (Kannada being the regional language of Belgaum, where the Registered Office of our Company is situated), each with wide circulation, respectively. In the pre-Offer advertisement, we shall state the Bid / Offer Opening Date and the Bid/Offer Closing Date. This advertisement, subject to the provisions of Section 30 of the Companies Act, 2013, shall be in the format prescribed in Part A of Schedule X of the SEBI ICDR Regulations 2018.

### **Information for Bidders**

In addition to the instructions provided to Bidders in the *General Information Document for Investing in Public Offers*, Bidders are requested to note the following additional information in relation to the Offer.

1. The relevant Designated Intermediary will enter each Bid option into the electronic Bidding system as a separate Bid and generate an acknowledgement slip (“**Acknowledgement Slip**”), for each price and demand option and give the same to the Bidder. Therefore, a Bidder can receive up to three Acknowledgement Slips for each Bid cum Application Form. It is the Bidder’s responsibility to obtain the TRS from the relevant Designated Intermediary. The registration of the Bid by the Designated Intermediary does not guarantee that the Equity Shares shall be allocated/ Allotted. Such Acknowledgement will be non-negotiable and by itself will not create any obligation of any kind. When a Bidder revises his or her Bid, he /she shall surrender the earlier Acknowledgement Slip and may request for a revised TRS from the relevant Designated Intermediary as proof of his or her having revised the previous Bid.
2. In relation to electronic registration of Bids, the permission given by the Stock Exchanges to use their network and software of the electronic bidding system should not in any way be deemed or construed to mean that the compliance with various statutory and other requirements by our Company, the Selling Shareholders and/or the BRLM are cleared or approved by the Stock Exchanges; nor does it in any manner warrant, certify or endorse the correctness or completeness of compliance with the statutory and other requirements, nor does it take any responsibility for the financial or other soundness of our Company, the Selling Shareholders, the management or any scheme or project of our Company; nor does it in any manner warrant, certify or endorse the correctness or completeness of any of the contents of the Draft Red Herring Prospectus or the Red Herring Prospectus; nor does it warrant that the Equity Shares will be listed or will continue to be listed on the Stock Exchanges.
3. In the event of an upward revision in the Price Band, Retail Individual Bidders who had Bid at Cut-off Price could either (i) revise their Bid or (ii) shall make additional payment based on the cap of the revised Price Band (such that the total amount i.e., original Bid Amount plus additional payment does not exceed ₹ 200,000 if the Bidder wants to continue to Bid at Cut-off Price). The revised Bids must be submitted to the same Designated Intermediary to whom the original Bid was submitted. If the total amount (i.e., the original Bid Amount plus additional payment) exceeds ₹ 200,000, the Bid will be considered for allocation under the Non-Institutional Portion. If, however, the Retail Individual Bidder does not either revise the Bid or make additional payment and the Offer Price is higher than the cap of the Price Band prior to revision, the number of Equity Shares Bid for shall be adjusted downwards for the purpose of allocation, such that no additional payment would be required from the Retail Individual Bidder and the Retail Individual Bidder is deemed to have approved such revised Bid at Cut-off Price.
4. In the event of a downward revision in the Price Band, Retail Individual Bidders who have bid at Cut-off Price may revise their Bid; otherwise, the excess amount paid at the time of Bidding would be unblocked after Allotment is finalised.
5. Any revision of the Bid shall be accompanied by instructions to block the incremental amount, if any, to be paid on account of the upward revision of the Bid.



## Signing of the Underwriting Agreement and the RoC Filing

Our Company and the Selling Shareholders intend to enter into an Underwriting Agreement with the Underwriters on or immediately after the finalisation of the Offer Price. After signing the Underwriting Agreement, the Company will file the Prospectus with the RoC. The Prospectus would have details of the Offer Price, Anchor Investor Offer Price, Offer size and underwriting arrangements and would be complete in all material respects.

### GENERAL INSTRUCTIONS

In addition to the general instructions provided in the sub-section “*General Information Document for Investing in Public Offers*” Bidders are requested to note the additional instructions provided below.

#### **Do's:**

1. Check if you are eligible to apply as per the Red Herring Prospectus and under applicable law, rules, regulations, guidelines and approvals;
2. Ensure that you have Bid within the Price Band;
3. Read all the instructions carefully and complete the Bid cum Application Form in the prescribed form;
4. Ensure that the details about the PAN, DP ID and Client ID are correct and the Bidders depository account is active, as Allotment of the Equity Shares will be in the dematerialised form only;
5. Ensure that your Bid cum Application Form, bearing the stamp of a Designated Intermediary is submitted to the Designated Intermediary at the Bidding Centre within the prescribed time, except in case of electronic forms.
6. In case of joint Bids, ensure that the first applicant is the ASBA Account holder, and also signs the Bid cum Application Form (for all Bidders other than RIIs bidding using the UPI mechanism);
7. All Bidders (other than Anchor Investors) should submit their Bids through the ASBA process only;
8. RIIs bidding using the UPI mechanism should ensure that the correct UPI ID is mentioned in the Bid cum Application Form and that you use only your own bank account linked UPI ID (only for RIIs using the UPI Mechanism) to make an application in the Offer;
9. RIIs bidding shall ensure that the bank, with which it has its bank account, where the funds equivalent to the application amount are available for blocking is UPI 2.0 certified by NPCI;
10. With respect to Bids by SCSBs, ensure that you have a separate account in your own name with any other SCSB having clear demarcated funds for applying under the ASBA process and that such separate account (with any other SCSB) is used as the ASBA Account with respect to your Bid;
11. Ensure that you request for and receive a stamped Acknowledgement Slip of the Bid cum Application Form for all your Bid options from the concerned Designated Intermediary as proof of registration of the Bid cum Application Form;
12. Ensure that you have funds equal to the Bid Amount in the ASBA Account with the SCSB before submitting the ASBA Form to any of the Designated Intermediaries;
13. Instruct your respective banks to release the funds blocked in accordance with the ASBA process;
14. Submit revised Bids to the same Designated Intermediary, through whom the original Bid was placed and obtain a revised Acknowledgement Slip;
15. Except for Bids (i) on behalf of the Central or State Governments and the officials appointed by courts, who, in terms of a SEBI circular dated June 30, 2008, may be exempt from specifying their PAN for transacting in the securities market, (ii) Bids by persons resident in the State of Sikkim, who, in terms of the SEBI circular dated July 20, 2006, are exempted from specifying their PAN for transacting in the securities market, and (iii) any other category of Bidders, including without limitation, institutions, which are exempted from specifying, may be

exempted from specifying their PAN for transacting in the securities market, for Bids of all values, ensure that you have mentioned your PAN allotted under the Income Tax Act in the Bid cum Application Form. The exemption for the Central or the State Government and officials appointed by the courts and for investors residing in the State of Sikkim is subject to (a) the demographic details received from the respective depositories confirming the exemption granted to the beneficiary owner by a suitable description in the PAN field and the beneficiary account remaining in “active status”; and (b) in the case of residents of Sikkim, the address as per the demo graphic details evidencing the same;

16. Ensure that the Demographic Details are updated, true and correct in all respects;
17. Ensure that thumb impressions and signatures other than in the languages specified in the Eighth Schedule to the Constitution of India are attested by a Magistrate or a Notary Public or a Special Executive Magistrate under official seal;
18. Ensure that the name(s) given in the Bid cum Application Form is/are exactly the same as the name(s) in which the beneficiary account is held with the Depository Participant. In case of joint Bids, the Bid cum Application Form should contain only the name of the First Bidder whose name should also appear as the first holder of the beneficiary account held in joint names. Ensure that the signature of the First Bidder is included in the Bid cum Application Forms;
19. Ensure that you tick the correct investor category and the investor status, as applicable, in the Bid cum Application Form to ensure proper upload of your Bid in the electronic Bidding system of the Stock Exchanges;
20. Ensure that for Bids under power of attorney or by limited companies, corporate, trust etc., relevant documents are submitted;
21. Ensure that Bids submitted by any person outside India should be in compliance with applicable foreign and Indian laws;
22. Ensure that the DP ID, the Client ID and the PAN mentioned in the Bid cum Application Form and entered into the electronic system of the Stock Exchanges by the relevant Designated Intermediary match with the DP ID, Client ID and PAN available in the Depository database;
23. Bidders should note that in case the DP ID, Client ID, UPI ID (if applicable) and the PAN mentioned in their Bid cum Application Form and entered into the online system of the Stock Exchanges by the relevant Designated Intermediary, do not match with the DP ID, Client ID, UPI ID (if applicable) and PAN available in the Depository database, then such Bids are liable to be rejected. Where the Bid cum Application Form is submitted in joint names, ensure that the beneficiary account is also held in the same joint names and such names are in the same sequence in which they appear in the Bid cum Application Form
24. Ensure that the Bid cum Application Forms are delivered by the Bidders within the time prescribed as per the Bid cum Application Form and the Red Herring Prospectus;
25. Ensure that while Bidding through a Designated Intermediary, the ASBA Form is submitted to a Designated Intermediary in a Bidding Centre and that the SCSB where the ASBA Account, as specified in the ASBA Form, is maintained has named at least one branch at that location for the Designated Intermediary to deposit ASBA Forms (a list of such branches is available on the website of SEBI at <http://www.sebi.gov.in>).
26. For RIIs bidding using the UPI mechanism, ensure that you approve the Mandate Request generated by the Sponsor Bank to authorise blocking of funds equivalent to application amount and subsequent debit of funds in case of allotment, in a timely manner;
27. Ensure that you have mentioned the correct ASBA Account number in the ASBA Form; and
28. In relation to the ASBA Bids, ensure that you have correctly signed the authorization/undertaking box in the ASBA Form, or have otherwise provided an authorisation to the SCSB or Sponsor Bank, as applicable, via the electronic mode, for blocking funds in the ASBA Account equivalent to the Bid Amount mentioned in the ASBA Form.

29. RIIs shall ensure that details of the Bid are reviewed and verified by opening the attachment in the UPI Mandate Request and then proceed to authorise the UPI Mandate Request using his/her UPI PIN. Upon the authorization of the mandate using his/her UPI PIN, an RII may be deemed to have verified the attachment containing the application details of the RII in the UPI Mandate Request and have agreed to block the entire Bid Amount and authorized the Sponsor Bank to block the Bid Amount mentioned in the Bid Cum Application Form.
30. RIIs bidding using the UPI mechanism should mention valid UPI ID of only the Applicant (in case of single account) and of the first Applicant (in case of joint account) in the Bid cum Application Form.
31. RIIs who wish to revise their Bids using the UPI Mechanism, should submit the revised Bid with the Designated Intermediaries, pursuant to which RIIs should ensure acceptance of the UPI Mandate Request received from the Sponsor Bank to authorise blocking of funds equivalent to the revised Bid Amount in the RIB's ASBA Account
32. RIIs bidding using the UPI mechanism, who have revised their Bids subsequent to making the initial Bid, should also approve the revised Mandate Request generated by the Sponsor Bank to authorise blocking of funds equivalent to the revised Bid Amount and subsequent debit of funds in case of allotment in a timely manner.

The Bid cum Application Form is liable to be rejected if the above instructions, as applicable, are not complied with.

***Don'ts:***

1. Do not Bid for lower than the minimum Bid size;
2. Do not Bid or revise the Bid to less than the Floor Price or higher than the Cap Price;
3. Do not Bid on another Bid cum Application Form after you have submitted a Bid to a Designated Intermediary;
4. Do not pay the Bid Amount by cheques and demand drafts or in cash, by money order or by postal order or by stockinvest or any mode other than blocked amounts in the bank account maintained with SCSB;
5. Do not send ASBA Forms by post. Instead submit the same to only a Designated Intermediary;
6. Do not Bid on a physical ASBA Form that does not have the stamp of a Designated Intermediary and not submit the Bid cum Application Forms to the Escrow Collection Bank(s) (assuming that such bank is not an SCSB), the BRLM or the Registrar to the Offer (assuming that the Registrar to the Offer is not one of the CRTAs);
7. Anchor Investors should not Bid through the ASBA process;
8. Bidders bidding in QIB and Non- Institutional Bidders category cannot Bid at the Cut-off Price.;
9. Do not Bid for a Bid Amount exceeding ₹ 200,000.00 (for Bids by Retail Individual Bidders);
10. Do not fill up the Bid cum Application Form such that the Equity Shares Bid for exceeds the Offer size and/ or investment limit or maximum number of the Equity Shares that can be held under the applicable laws or regulations or maximum amount permissible under the applicable regulations;
11. Do not submit the General Index Register number instead of the PAN;
12. Do not instruct your respective banks to release the funds blocked in your ASBA Account;
13. Do not submit the Bids without instructions to block funds equivalent to the Bid Amount in the ASBA Account;
14. Do not submit incorrect UPI ID details if you are a RII bidding through the UPI mechanism;
15. Do not submit incorrect details of the DP ID, Client ID and PAN or provide details for a beneficiary account which is suspended or for which details cannot be verified by the Registrar to the Offer;
16. Do not submit Bids on plain paper or on incomplete or illegible Bid cum Application Forms or on Bid cum Application Forms in a colour prescribed for another category of Bidder;

17. If you are a QIB, do not submit your Bid after 3.00 p.m. on the QIB Bid/Offer Closing Date;
18. Do not submit a Bid in case you are not eligible to acquire Equity Shares under applicable law or your relevant constitutional documents or otherwise
19. If you are a Non-Institutional Bidder or Retail Individual Bidder, do not submit your Bid after 3.00 p.m. on the Bid/Offer Closing Date;
20. Do not Bid if you are not competent to contract under the Indian Contract Act, 1872;
21. Do not withdraw your Bid or lower the size of your Bid (in terms of quantity of the Equity Shares or the Bid Amount) at any stage, if you are a QIB or a Non-Institutional Bidders;
22. Do not submit more than one ASBA Forms per ASBA Account;
23. Do not submit more than one Bid cum Application Form for each UPI ID in case of RIIs bidding through the Designated Intermediaries using the UPI mechanism.
24. Do not submit a Bid using the UPI, if you are not a RII;
25. Do not submit ASBA Bids to a Designated Intermediary at a Bidding Centre unless the SCSB where the ASBA Account is maintained, as specified in the ASBA Form, has named at least one branch in the relevant Bidding Centre, for the Designated Intermediary to deposit ASBA Forms (a list of such branches is available on the website of SEBI at <http://www.sebi.gov.in>); and
26. Do not submit a Bid in case you are not eligible to acquire Equity Shares under applicable law or your relevant constitutional documents or otherwise;
27. Do not link the UPI ID with a bank account maintained with a bank that is not UPI 2.0 certified by the NPCI in case of Bids submitted by RII Bidder using the UPI mechanism.
28. Do not submit a Bid cum Application Form with third party UPI ID (in case of in case of Bids submitted by RII Bidder using the UPI mechanism).

The Bid cum Application Form is liable to be rejected if the above instructions, as applicable, are not complied with.

#### **Issuance of a Confirmation of Allocation Note (“CAN”) and Allotment in the Offer**

1. Upon approval of the basis of allotment by the Designated Stock Exchange, the BRLM or Registrar to the Offer shall send to the SCSBs a list of their Bidders who have been allocated Equity Shares in the Offer.
2. The Registrar will then dispatch a CAN to their Bidders who have been allocated Equity Shares in the Offer. The dispatch of a CAN shall be deemed a valid, binding and irrevocable contract for the Bidder.

#### **Payment instructions**

The entire Offer Price of [●] per Equity Share is payable on Application. In case of allotment of lesser number of Equity Shares than the number applied, then the Registrar shall instruct the SCSBs to unblock the excess amount paid on Application to the Bidders.

#### **INSTRUCTIONS FOR COMPLETING THE BID CUM APPLICATION FORM**

In addition to the instructions for completing the Bid cum Application Form provided in the sub-section “*General Information Document for Investing in Public Offers – Applying in the Offer – Instructions for filing the Bid cum Application Form/ Application Form*” Bidders are requested to note the additional instructions provided below.

1. Thumb impressions and signatures other than in the languages specified in the Eighth Schedule in the Constitution of India must be attested by a Magistrate or a Notary Public or a Special Executive Magistrate under official seal. Bids must be in single name or in joint names (not more than three, and in the same order as their Depository Participant details).

2. ASBA Bids must be made in a single name or in joint names (not more than three, and in the same order as their details appear with the Depository Participant), and completed in full, in BLOCK LETTERS in ENGLISH and in accordance with the instructions contained in the Red Herring Prospectus and in the ASBA Form.
3. Bids on a repatriation basis shall be in the names of FIIs or FPIs but not in the names of minors, OCBs, firms or partnerships and foreign nationals.

### **Designated Date and Allotment**

- (a) Our Company will ensure that the Allotment and credit to the successful Bidder's depository account will be completed within six Working Days, or such period as may be prescribed by SEBI, of the Bid/Offer Closing Date or such other period as may be prescribed.
- (b) Equity Shares will be issued and Allotment shall be made only in the dematerialised form to the Allottees.
- (c) Allottees will have the option to re-materialise the Equity Shares so Allotted as per the provisions of the Companies Act, 2013 and the Depositories Act.

### **Communications**

All future communications in connection with Bids made in this Offer should be addressed to the Registrar to the Offer, quoting the full name of the sole or First Bidder, Bid cum Application Form number, Bidders Depository Account Details, number of Equity Shares applied for, date of Bid cum Application Form, name and address of the member of the Syndicate or the SCSB / Designated Intermediary, where the Bid was submitted and bank account number in which the amount equivalent to the Bid Amount was blocked.

Bidders can contact the Compliance Officer or the Registrar to the Offer, in case of any Pre-Offer or Post-Offer related problems such as non-receipt of letters of Allotment, credit of allotted shares in the respective beneficiary accounts, unblocking of funds, etc.

### **Grounds for Technical Rejections**

In addition to the grounds for rejection of Bids on technical grounds as provided in the "*General Information Document for Investing in Public Offers – Offer Procedure in Book Built Offer – Rejection and Responsibility for Upload of Bids – Grounds for Technical Rejections*" Bidders are requested to note that Bids may be rejected on the following additional technical grounds.

1. Bid submitted without payment of the entire Bid Amount;
2. Bids submitted by Bidders which do not contain details of the Bid Amount and the bank account details in the ASBA Form;
3. Bids submitted on a plain paper;
4. Bids under the UPI Mechanism submitted by RIIs using third party bank accounts or using a third party linked bank account UPI ID;
5. Bids by HUFs not mentioned correctly as given in the sub-section "*Who can Bid?*" on page no. 332 of this Red Herring Prospectus;
6. ASBA Form submitted to a Designated Intermediary does not bear the stamp of the Designated Intermediary;
7. Bids submitted without the signature of the First Bidder or sole Bidder;
8. With respect to ASBA Bids, the ASBA Form not being signed by the account holders, if the account holder is different from the Bidder;
9. Bids by persons for whom PAN details have not been verified and whose beneficiary accounts are 'suspended for credit' in terms of SEBI circular (reference number: CIR/MRD/DP/ 22 /2010) dated July 29, 2010;

10. GIR number furnished instead of PAN;
11. Bids by Retail Individual Bidders with Bid Amount for a value of more than ₹ 200,000.00;
12. Bids by persons who are not eligible to acquire Equity Shares in terms of all applicable laws, rules, regulations, guidelines and approvals;
13. Bids by Bidders (who are not Anchor Investors) accompanied by cheques or demand drafts;
14. Bids accompanied by stock invest, money order, postal order or cash;
15. Bids uploaded by QIBs after 4.00 p.m. on the QIB Bid / Offer Closing Date and by Non-Institutional Bidders uploaded after 4.00 p.m. on the Bid/Offer Closing Date, and Bids by Retail Individual Bidders uploaded after 5.00 p.m. on the Bid/Offer Closing Date, unless extended by the Stock Exchanges; and
16. Bids by OCB.

#### **Method of allotment as may be prescribed by SEBI from time to time**

Our Company will not make any Allotment in excess of the Equity Shares through the Offer Document except in case of over-subscription for the purpose of rounding off to make Allotment, in consultation with the Designated Stock Exchange. Further, upon over-subscription, an allotment of not more than ten per cent of the Net Offer may be made for the purpose of making Allotment in minimum lots.

The Allotment of Equity Shares to applicants other than to the Retail Individual Investors shall be on a proportionate basis within the respective investor categories and the number of securities allotted shall be rounded off to the nearest integer, subject to minimum allotment being equal to the minimum application size as determined and disclosed.

The Allotment of Equity Shares to each Retail Individual Investors shall not be less than the minimum bid lot, subject to the availability of shares in Retail Individual Investors Portion, and the remaining available Equity Shares, if any, shall be Allotted on a proportionate basis.

#### **Depository Arrangements**

The Allotment of the Equity Shares in the Offer shall be only in a de-materialised form, (i.e., not in the form of physical certificates but be fungible and be represented by the statement issued through the electronic mode). In this context, two agreements had been signed among our Company, the respective Depositories and the Registrar to the Offer:

1. Agreement dated December 28, 2017 among NSDL, our Company and the Registrar to the Offer.
2. Agreement dated April 23, 2019 among CDSL, our Company and Registrar to the Offer.

#### **Impersonation**

**Attention of the Bidders is specifically drawn to the provisions of sub-section (1) of Section 38 of the Companies Act, which is reproduced below:**

*“Any person who:*

- a) makes or abets making of an application in a fictitious name to a company for acquiring, or subscribing for, its securities; or*
- b) makes or abets making of multiple applications to a company in different names or in different combinations of his name or surname for acquiring or subscribing for its securities; or*
- c) Otherwise induces directly or indirectly a company to allot, or register any transfer of, securities to him, or to any other person in a fictitious name, shall be liable for action under Section 447”*



The liability prescribed under Section 447 of the Companies Act, 2013 includes imprisonment for a term which shall not be less than six months extending up to 10 years (provided that where the fraud involves public interest, such term shall not be less than three years) and fine of an amount not less than the amount involved in the fraud, extending up to three times of such amount.

## **UNDERTAKINGS BY OUR COMPANY**

Our Company undertakes the following:

1. That if our Company and/or the Selling Shareholders does not proceed with the Offer after the Bid/Offer Closing Date but prior to Allotment, the reason thereof shall be given as a public notice within two days of the Bid/Offer Closing Date. The public notice shall be issued in the same newspapers where the pre- Offer advertisements were published. The stock exchanges on which the Equity Shares are proposed to be listed shall also be informed promptly;
2. That the complaints received in respect of the Offer shall be attended to by the Company expeditiously and satisfactorily;
3. That all steps for completion of the necessary formalities for listing and commencement of trading at all the Stock Exchanges where the Equity Shares are proposed to be listed are taken within six Working Days of the Bid/Offer Closing Date or such other period as may be prescribed;
4. If Allotment is not made, application monies will be refunded/unblocked in the ASBA Accounts within 6 days from the Bid/Offer Closing Date or such lesser time as specified by SEBI, failing which interest will be due to be paid to the Bidders at the rate of 15.00% per annum for the delayed period;
5. That where refunds (to the extent applicable) are made through electronic transfer of funds, a suitable communication shall be sent to the Bidder within 6 days from the Bid/Offer Closing Date or such lesser time as specified by SEBI, giving details of the bank where refunds shall be credited along with the amount and expected date of electronic credit for the refund;
6. That the Promoters' contribution in full, if applicable, shall be brought in advance before the Offer opens for subscription
7. That funds required for making refunds to unsuccessful applicants as per mode(s) disclosed shall be made available to the Registrar to the Offer by the Company;
8. No further offer of Equity Shares shall be made until the Equity Shares offered through the Red Herring Prospectus are listed or until the Bid monies are unblocked in the ASBA Accounts on account of non-listing, under-subscription etc.;
9. That if our Company and the Selling Shareholders withdraw the Offer after the Bid/Offer Closing Date, our Company shall be required to file a fresh offer document with the SEBI, in the event our Company and / or the Selling Shareholders subsequently decides to proceed with the Offer;
10. That our Company shall comply with such disclosure and accounting norms as may be specified by SEBI from time to time;
11. That the allotment of securities/refund confirmation to Eligible NRIs shall be dispatched within specified time;
12. That adequate arrangements shall be made to collect all Bid cum Application Forms; and
13. That our Company shall not have recourse to the Offer Proceeds until the final approval for listing and trading of the Equity Shares from all the Stock Exchanges.

## **Undertaking by the Selling Shareholder**

Only statements and undertakings which are specifically "confirmed" or "undertaken" by the Selling Shareholders in this Red Herring Prospectus shall be deemed to be "statements and undertakings made by the Selling Shareholder." All other statements and/ or undertakings in this Red Herring Prospectus shall be statements and undertakings made by our

Company even if the same relates to the Selling Shareholders. Each Selling Shareholder severally and not jointly, specifically confirms and undertakes the following in respect of itself and the Equity Shares being offered by it pursuant to the Offer for Sale:

2. Its respective portion of the Offered Shares shall be transferred in the Offer free and clear of any pre-emptive rights, liens, mortgages, charges, pledges, trusts or any other encumbrance or transfer restrictions, both present and future, in a manner prescribed under Applicable Law in relation to the Offer, and without any objection by it and in accordance with the instructions of the Registrar to the Offer.
3. Its respective portion of the Offered Shares have been held by such Selling Shareholders for a minimum period of one year prior to the date of filing the Draft Red Herring Prospectus, such period determined in accordance with Regulation 26 (6) of the SEBI ICDR Regulations.
4. It is the legal and beneficial owner and has full title of its respective portion of the Offered Shares.
5. That it shall provide all reasonable co-operation as requested by our Company and the BRLM in relation to the completion of the Allotment and dispatch of the Allotment Advice and CAN, if required, and refund orders (as applicable) to the requisite extent of its respective portion of the Offered Shares.
6. It will not have recourse to the proceeds of the Offer for Sale, until approval for final listing and trading of the Equity Shares is received from the Stock Exchanges.
7. It will deposit its respective portion of the Offered Shares in an escrow account opened with the Share Escrow Agent prior to filing of this Red Herring Prospectus with the RoC.
8. It shall not offer any incentive, whether direct or indirect, in any manner, whether in cash or kind or services or otherwise, to any person for making a Bid in the Offer, and shall not make any payment, whether direct or indirect, whether in the nature of discounts, commission, allowance or otherwise, to any person who makes a Bid in the Offer.
9. That it will provide such reasonable support and extend such reasonable cooperation as may be required by our Company and the BRLM in redressal of such investor grievances that pertain to the Equity Shares held by it and being offered pursuant to the Offer.

The Selling Shareholders have authorised the Company Secretary and Compliance Officer of our Company and the Registrar to the Offer to redress any complaints received from Bidders in respect of the Offer for Sale.

#### **Utilisation of Net proceeds**

Our Company and the Selling Shareholders specifically confirms and declares that:

- (i) all monies received out of Offer of specified securities to public shall be transferred to separate bank account other than the bank account referred to in sub-section (3) of section 40 of the Companies Act, 2013;
- (ii) details of all monies utilised out of the Offer referred to in sub-item(i) shall be disclosed and continue to be disclosed till the time any part of the Fresh Issue proceeds remains un-utilised under an appropriate separate head in the balance-sheet of the issuer indicating the purpose for which such monies had been utilised; and
- (iii) details of all un-utilised monies out of the Fresh Issue, if any, shall be disclosed under an appropriate separate head in the balance sheet of the issuer indicating the form in which such un-utilised monies have been invested.

## RESTRICTIONS ON FOREIGN OWNERSHIP OF INDIAN SECURITIES

Foreign investment in Indian securities is regulated through the Industrial Policy, 1991 of the Government of India and FEMA. While the Industrial Policy, 1991 prescribes the limits and the conditions subject to which foreign investment can be made in different sectors of the Indian economy, FEMA regulates the precise manner in which such investment may be made. The Union Cabinet, as provided in the Cabinet Press Release dated May 24, 2017, has given its approval for phasing out the FIPB. Accordingly, the process for foreign direct investment (“FDI”) and approval from the Government of India will now be handled by the concerned ministries or departments, in consultation with the Department of Industrial Policy and Promotion, Ministry of Commerce and Industry, Government of India (“DIPP”), Ministry of Finance, Department of Economic Affairs, FIPB section, through a memorandum dated June 5, 2017 has notified the specific ministries handling relevant sectors.

The Government has from time to time made policy pronouncements on FDI through press notes and press releases. DIPP, issued the Consolidated FDI Policy Circular of 2016 (“FDI Circular 2016”), which, with effect from June 7, 2016, consolidated and superseded all previous press notes, press releases and clarifications on FDI issued by the DIPP that were in force and effect as on June 7, 2016. The Government proposes to update the consolidated circular on FDI policy once every year and therefore, FDI Circular 2016 will be valid until the DIPP issues an updated circular.

The transfer of shares between an Indian resident and a non-resident does not require the prior approval of the RBI, provided that (i) the activities of the investee company are under the automatic route under the foreign direct investment policy and transfer does not attract the provisions of the Takeover Regulations; (ii) the non-resident shareholding is within the sectoral limits under the FDI policy; and (iii) the pricing is in accordance with the guidelines prescribed by the SEBI/RBI.

As per the existing policy of the Government of India, OCBs cannot participate in this Offer.

**The Equity Shares offered in the Offer have not been and will not be registered under the Securities Act, and may not be offered or sold within the United States, except pursuant to an exemption from, or in a transaction not subject to, the registration requirements of the Securities Act and applicable U.S. state securities laws. Accordingly, the Equity Shares are being offered and sold (i) within the United States to persons reasonably believed to be “qualified institutional investors” (as defined in Rule 144A under the Securities Act) pursuant to Rule 144A under the Securities Act or other applicable exemption under the Securities Act and (ii) outside the United States in offshore transactions in reliance on Regulation S under the Securities Act and the applicable laws of the jurisdictions where such offers and sales occur.**

**The above information is given for the benefit of the Bidders. Our Company and the BRLM are not liable for any amendments or modification or changes in applicable laws or regulations, which may occur after the date of this Red Herring Prospectus. Bidders are advised to make their independent investigations and ensure that their Bids are not in violation of laws or regulations applicable to them.**

## SECTION X - MAIN PROVISIONS OF ARTICLES OF ASSOCIATION

*Pursuant to the Companies Act and the SEBI ICDR Regulations, the main provisions of the Articles of Association are detailed below. Capitalised terms used in this section have the meaning given to them in the Articles of Association.*

*Each provision below is numbered as per the corresponding article number in the Articles of Association and defined terms herein have the meaning given to them in the Articles of Association.*

1. The regulations contained in Table F of the first schedule to the Companies Act, 2013 (hereinafter referred as Table F) shall apply to this Company in so far as are applicable to Public Company and are not amended, modified or substituted by the following Articles.

### ***Interpretation***

2. In the interpretation of these Articles, unless repugnant to the subject or context:-

- a) “The company” or “this company” means VISHWARAJ SUGAR INDUSTRIES LIMITED
- b) “The Act” means the Companies Act 2013, or any statutory modification or re- enactment thereof for the time being in force.
- c) “Auditor” means and includes those persons appointed as such for the time being by the Company.
- d) “Board Meeting” means meeting of the Directors duly and constituted or as the case may be, the Directors assembled at a Board.
- e) “Capital” means the share capital for the time being raised or authorized to be raised, for the Company.
- f) “Debenture” includes the Debenture stock.
- g) “Directors” mean the Directors for the time being of the Company of as the case may be the Directors assembled at as Board.
- h) “Dividend” includes bonus.
- i) Gender

Word importing the masculine gender also includes the feminine gender.

- j) In Writing or Written

“In Writing” or “Written” includes printing, lithography and other modes of representing or reproducing words in a visible form.

- k) Member

“Member” means the duly registered holder from time to time of the shares of the Company and includes the subscriber to the Memorandum of the Company.

- l) Meeting or Annual General Meeting

“Annual General Meeting” means a General Meeting of the members duly called and constituted and any adjourned holding thereof in accordance of section 96 of the Act.

- m) Meeting or Extraordinary general meeting

“Extraordinary General Meeting” means Extraordinary General meeting of the Members duly called and constituted and any adjourned holding thereof.

n) Month

“Month” means a calendar month

o) Office

“Office” means the registered office for the time being of the Company.

p) Paid up

Paid up” includes credited as paid up.

q) *Persons*

“Persons” includes corporation and firms as well as individuals.

r) *Register of members*

“Register of member” means the Register of members to be kept pursuant to the Act.

s) *The Registrar*

“The Registrar” means the Registrar of the Companies (as defined under Section 2(75) of the Act of the state in which the office of the Company is for the time being situated.

t) *Officer*

“Officer” includes any director, manager or secretary, or any person in accordance with whose direction or instruction the board of Director or any or more of the directors is accustomed to act

u) *Seal*

“Seal” means the Common Seal for the time being of the Company.

v) *Share*

“Share” means share in the share capital of a company and includes stock except where a distinction between stock and share is expressed or implied.

w) *Special Resolution*

“Special Resolution” shall have the meaning assigned thereto by section 114 of Companies Act, 2013.

x) *Year and Financial Year.*

“Year” means the calendar year and “financial year” shall have the meaning assigned thereto by section 2(41) of the Act.

***Public Company***

3. The company is a Public Company within the meaning of section 2(71) of the Companies Act, 2013 with a minimum paid up capital of Rupees Five Lakhs or such higher amount as may be prescribed from time to time.

***Share capital and variation of rights***

4. (i) The Authorised Share Capital of the Company shall be as laid down in Memorandum of Association of the Company.
- (ii) Subject to the provisions of the Companies Act 2013 and the applicable Rules made thereunder, the Company / Board shall have power to issue / allot shares, whether on preferential basis or otherwise, from time to time

and the shares shall be under the control of the Directors who may allot or otherwise dispose off the same to such persons, on such terms and conditions and at such times as the Directors think fit.

5. (i) Every person whose name is entered as a member in the register of members shall be entitled to receive within two months after incorporation, in case of subscribers to the memorandum or after allotment or within one month after the application for the registration of transfer or transmission or within such other period as the conditions of issue shall be provided:—
  - (a) one certificate for all his shares without payment of any charges; or
  - (b) several certificates, each for one or more of his shares, upon payment of twenty rupees for each certificate after the first.
- (ii) Every certificate shall be under the seal and shall specify the shares to which it relates and the amount paid-up thereon.
- (iii) In respect of any share or shares held jointly by several persons, the company shall not be bound to issue more than one certificate, and delivery of a certificate for a share to one of several joint holders shall be sufficient delivery to all such holders.
6. (i) If any share certificate be worn out, defaced, mutilated or torn or if there be no further space on the back for endorsement of transfer, then upon production and surrender thereof to the company, a new certificate may be issued in lieu thereof, and if any certificate is lost or destroyed then upon proof thereof to the satisfaction of the company and on execution of such indemnity as the company deem adequate, a new certificate in lieu thereof shall be given. Every certificate under this Article shall be issued on payment of twenty rupees for each certificate.
- (ii) The company may issue new share certificates pursuant to consolidation or sub-division of share certificate(s) upon written request received from shareholder together with production and surrender of respective original share certificate(s). Every certificate under this Article shall be issued on payment of twenty rupees for each certificate.
- (iii) The provisions of Articles (5) and (6) shall mutatis mutandis apply to debentures of the company.
7. Except as required by law, no person shall be recognized by the company as holding any share upon any trust, and the company shall not be bound by, or be compelled in any way to recognize (even when having notice thereof) any equitable, contingent, future or partial interest in any share, or any interest in any fractional part of a share, or (except only as by these regulations or by law otherwise provided) any other rights in respect of any share except an absolute right to the entirety thereof in the registered holder.
8. (i) The company may exercise the powers of paying commissions conferred by sub-section (6) of section 40, provided that the rate per cent. or the amount of the commission paid or agreed to be paid shall be disclosed in the manner required by that section and rules made thereunder.
- (ii) The rate or amount of the commission shall not exceed the rate or amount prescribed in rules made under sub-section (6) of section 40.
- (iii) The commission may be satisfied by the payment of cash or the allotment of fully or partly paid shares or partly in the one way and partly in the other.
9. (i) If at any time the share capital is divided into different classes of shares, the rights attached to any class (unless otherwise provided by the terms of issue of the shares of that class) may, subject to the provisions of section 48 and whether or not the company is being wound up, be varied with the consent in writing of the holders of three-fourths of the issued shares of that class, or with the sanction of a special resolution passed at a separate meeting of the holders of the shares of that class.
- (ii) To every such separate meeting, the provisions of these regulations relating to general meetings shall mutatis mutandis apply, but so that the necessary quorum shall be at least two persons holding at least one-third of the issued shares of the class in question.



10. The rights conferred upon the holders of the shares of any class issued with preferred or other rights shall not, unless otherwise expressly provided by the terms of issue of the shares of that class, be deemed to be varied by the creation or issue of further shares ranking pari passu therewith.
11. Subject to the provisions of section 55, any preference shares may, with the sanction of an ordinary resolution, be issued on the terms that they are to be redeemed on such terms and in such manner as the company before the issue of the shares may, by special resolution, determine.

#### *Lien*

12. (i) The company shall have a first and paramount lien—
  - (a) on every share (not being a fully paid share), for all monies (whether presently payable or not) called, or payable at a fixed time, in respect of that share; and
  - (b) on all shares (not being fully paid shares) standing registered in the name of a single person, for all monies presently payable by him or his estate to the company:

Provided that the Board of directors may at any time declare any share to be wholly or in part exempt from the provisions of this clause.

- (ii) The company's lien, if any, on a share shall extend to all dividends payable and bonuses declared from time to time in respect of such shares.
- (iii) The fully paid shares shall be free from all lien and that in the case of partly paid shares the Company's lien shall be restricted to monies called or payable at a fixed time in respect of such shares.

13. The company may sell, in such manner as the Board thinks fit, any shares on which the company has a lien:

Provided that no sale shall be made—

- (a) unless a sum in respect of which the lien exists is presently payable; or
  - (b) until the expiration of fourteen days after a notice in writing stating and demanding payment of such part of the amount in respect of which the lien exists as is presently payable, has been given to the registered holder for the time being of the share or the person entitled thereto by reason of his death or insolvency.
14. (i) To give effect to any such sale, the Board may authorise some person to transfer the shares sold to the purchaser thereof.
  - (ii) The purchaser shall be registered as the holder of the shares comprised in any such transfer.
  - (iii) The purchaser shall not be bound to see to the application of the purchase money, nor shall his title to the shares be affected by any irregularity or invalidity in the proceedings in reference to the sale.
15. (i) The proceeds of the sale shall be received by the company and applied in payment of such part of the amount in respect of which the lien exists as is presently payable.
  - (ii) The residue, if any, shall, subject to a like lien for sums not presently payable as existed upon the shares before the sale, be paid to the person entitled to the shares at the date of the sale.

#### *Calls on shares*

16. (i) The Board may, from time to time, make calls upon the members in respect of any monies unpaid on their shares (whether on account of the nominal value of the shares or by way of premium) and not by the conditions of allotment thereof made payable at fixed times:

Provided that no call shall exceed one-fourth of the nominal value of the share or be payable at less than one month from the date fixed for the payment of the last preceding call.

- (ii) Each member shall, subject to receiving at least fourteen days' notice specifying the time or times and place of payment, pay to the company, at the time or times and place so specified, the amount called on his shares.
  - (iii) A call may be revoked or postponed at the discretion of the Board.
  - (iv) The option or right to make call on shares shall not be given to any person except with the sanction of the Company in General Meetings. That is, it may delegate power to make calls on shares subject to approval of the shareholders in a general meeting of the company.
17. A call shall be deemed to have been made at the time when the resolution of the Board authorising the call was passed and may be required to be paid by instalments.
18. The joint holders of a share shall be jointly and severally liable to pay all calls in respect thereof.
19. (i) If a sum called in respect of a share is not paid before or on the day appointed for payment thereof, the person from whom the sum is due shall pay interest thereon from the day appointed for payment thereof to the time of actual payment at ten per cent. per annum or at such lower rate, if any, as the Board may determine.
- (ii) The Board shall be at liberty to waive payment of any such interest wholly or in part.
20. (i) Any sum which by the terms of issue of a share becomes payable on allotment or at any fixed date, whether on account of the nominal value of the share or by way of premium, shall, for the purposes of these regulations, be deemed to be a call duly made and payable on the date on which by the terms of issue such sum becomes payable.
- (ii) In case of non-payment of such sum, all the relevant provisions of these regulations as to payment of interest and expenses, forfeiture or otherwise shall apply as if such sum had become payable by virtue of a call duly made and notified.
21. The Board—
- (a) may, if it thinks fit, receive from any member willing to advance the same, all or any part of the monies uncalled and unpaid upon any shares held by him; and
  - (b) upon all or any of the monies so advanced, may (until the same would, but for such advance, become presently payable) pay interest at such rate not exceeding, unless the company in general meeting shall otherwise direct, twelve per cent. per annum, as may be agreed upon between the Board and the member paying the sum in advance but shall not confer a right to dividend or to participate in profits.

#### *Transfer of shares*

22. (i) The Company shall use a Common form of transfer. The instrument of transfer of any share in the company shall be executed by or on behalf of both the transferor and transferee.
- (ii) The transferor shall be deemed to remain a holder of the share until the name of the transferee is entered in the register of members in respect thereof.
23. The Board may, subject to the right of appeal conferred by section 58 decline to register—
- (a) the transfer of a share, not being a fully paid share, to a person of whom they do not approve; or
  - (b) any transfer of shares on which the company has a lien.
24. The Board may decline to recognise any instrument of transfer unless—
- (a) the instrument of transfer is in the form as prescribed in rules made under sub-section (1) of section 56;
  - (b) the instrument of transfer is accompanied by the certificate of the shares to which it relates, and such other evidence as the Board may reasonably require to show the right of the transferor to make the transfer; and

- (c) the instrument of transfer is in respect of only one class of shares.
25. On giving not less than seven days' previous notice in accordance with section 91 and rules made thereunder, the registration of transfers may be suspended at such times and for such periods as the Board may from time to time determine:

Provided that such registration shall not be suspended for more than thirty days at any one time or for more than forty-five days in the aggregate in any year.

26. Subject to the provisions of Section 59 of Companies Act, 2013, the Board may decline to register any transfer of Shares on such grounds as it think fit in the benefit of the company (notwithstanding that the proposed transferee be already a Member), but in such case it shall, within two (2) months from the date the instrument of transfer was lodged with the Company, send to the transferee and the transferor notice of the refusal to register such transfer giving reasons for such refusal. Provided that registration of a transfer shall not be refused on the ground of the transferor being either alone or jointly with any other person or persons indebted to the Company on any account whatsoever.

#### *Transmission Of Shares*

27. (i) On the death of a member, the survivor or survivors where the member was a joint holder, and his nominee or nominees or legal representatives where he was a sole holder, shall be the only persons recognised by the company as having any title to his interest in the shares.
- (ii) Nothing in clause (i) shall release the estate of a deceased joint holder from any liability in respect of any share which had been jointly held by him with other persons.
28. (i) Any person becoming entitled to a share in consequence of the death or insolvency of a member may, upon such evidence being produced as may from time to time properly be required by the Board and subject as hereinafter provided, elect, either—
- (a) to be registered himself as holder of the share; or
- (b) to make such transfer of the share as the deceased or insolvent member could have made.
- (ii) The Board shall, in either case, have the same right to decline or suspend registration as it would have had, if the deceased or insolvent member had transferred the share before his death or insolvency.
29. (i) If the person so becoming entitled shall elect to be registered as holder of the share himself, he shall deliver or send to the company a notice in writing signed by him stating that he so elects.
- (ii) If the person aforesaid shall elect to transfer the share, he shall testify his election by executing a transfer of the share.
- (iii) All the limitations, restrictions and provisions of these regulations relating to the right to transfer and the registration of transfers of shares shall be applicable to any such notice or transfer as aforesaid as if the death or insolvency of the member had not occurred and the notice or transfer were a transfer signed by that member.
30. A person becoming entitled to a share by reason of the death or insolvency of the holder shall be entitled to the same dividends and other advantages to which he would be entitled if he were the registered holder of the share, except that he shall not, before being registered as a member in respect of the share, be entitled in respect of it to exercise any right conferred by membership in relation to meetings of the company:

Provided that the Board may, at any time, give notice requiring any such person to elect either to be registered himself or to transfer the share, and if the notice is not complied with within ninety days, the Board may thereafter withhold payment of all dividends, bonuses or other monies payable in respect of the share, until the requirements of the notice have been complied with.

### *Forfeiture Of Shares*

31. If a member fails to pay any call, or installment of a call, on the day appointed for payment thereof, the Board may, at any time thereafter during such time as any part of the call or installment remains unpaid, serve a notice on him requiring payment of so much of the call or installment as is unpaid, together with any interest which may have accrued.
32. The notice aforesaid shall—
  - (a) name a further day (not being earlier than the expiry of fourteen days from the date of service of the notice) on or before which the payment required by the notice is to be made; and
  - (b) state that, in the event of non-payment on or before the day so named, the shares in respect of which the call was made shall be liable to be forfeited.
33. If the requirements of any such notice as aforesaid are not complied with, any share in respect of which the notice has been given may, at any time thereafter, before the payment required by the notice has been made, be forfeited by a resolution of the Board to that effect.
34. (i) A forfeited share may be sold or otherwise disposed of on such terms and in such manner as the Board thinks fit.  
  
(ii) At any time before a sale or disposal as aforesaid, the Board may cancel the forfeiture on such terms as it thinks fit.
35. (i) A person whose shares have been forfeited shall cease to be a member in respect of the forfeited shares, but shall, notwithstanding the forfeiture, remain liable to pay to the company all monies which, at the date of forfeiture, were presently payable by him to the company in respect of the shares.  
  
(ii) The liability of such person shall cease if and when the company shall have received payment in full of all such monies in respect of the shares.
36. (i) A duly verified declaration in writing that the declarant is a director, the manager or the secretary, of the company, and that a share in the company has been duly forfeited on a date stated in the declaration, shall be conclusive evidence of the facts therein stated as against all persons claiming to be entitled to the share.  
  
(ii) The company may receive the consideration, if any, given for the share on any sale or disposal thereof and may execute a transfer of the share in favour of the person to whom the share is sold or disposed of.  
  
(iii) The transferee shall thereupon be registered as the holder of the share  
  
(iv) The transferee shall not be bound to see to the application of the purchase money, if any, nor shall his title to the share be affected by any irregularity or invalidity in the proceedings in reference to the forfeiture, sale or disposal of the share.
37. The provisions of these regulations as to forfeiture shall apply in the case of nonpayment of any sum which, by the terms of issue of a share, becomes payable at a fixed time, whether on account of the nominal value of the share or by way of premium, as if the same had been payable by virtue of a call duly made and notified.

### *Alteration Of Capital*

38. The company may, from time to time, by ordinary resolution increase the share capital by such sum, to be divided into shares of such amount, as may be specified in the resolution. The Authorised Share Capital shall be as per the clause V (a) of Memorandum of Association of the company.
39. Subject to the provisions of section 61, the company may, by ordinary resolution,—
  - (a) increase its authorised share capital by such amount as it thinks expedient.

- (b) consolidate and divide all or any of its share capital into shares of larger amount than its existing shares;
- (c) convert all or any of its fully paid-up shares into stock, and reconvert that stock into fully paid-up shares of any denomination;
- (d) sub-divide its existing shares or any of them into shares of smaller amount than is fixed by the memorandum;
- (e) cancel any shares which, at the date of the passing of the resolution, have not been taken or agreed to be taken by any person.

40. Where shares are converted into stock,—

(a) the holders of stock may transfer the same or any part thereof in the same manner as, and subject to the same regulations under which, the shares from which the stock arose might before the conversion have been transferred, or as near thereto as circumstances admit:

Provided that the Board may, from time to time, fix the minimum amount of stock transferable, so, however, that such minimum shall not exceed the nominal amount of the shares from which the stock arose.

(b) the holders of stock shall, according to the amount of stock held by them, have the same rights, privileges and advantages as regards dividends, voting at meetings of the company, and other matters, as if they held the shares from which the stock arose; but no such privilege or advantage (except participation in the dividends and profits of the company and in the assets on winding up) shall be conferred by an amount of stock which would not, if existing in shares, have conferred that privilege or advantage.

(c) such of the regulations of the company as are applicable to paid-up shares shall apply to stock and the words “share” and “shareholder” in those regulations shall include “stock” and “stock-holder” respectively.

41. The company may, by special resolution, reduce in any manner and with, and subject to, any incident authorised and consent required by law,—
- (a) its share capital;
  - (b) any capital redemption reserve account; or
  - (c) any share premium account.

#### *Capitalisation of profits*

42. (i) The company in general meeting may, upon the recommendation of the Board resolve—

- (a) that it is desirable to capitalise any part of the amount for the time being standing to the credit of any of the company’s reserve accounts, or to the credit of the profit and loss account, or otherwise available for distribution; and
- (b) that such sum be accordingly set free for distribution in the manner specified in clause (ii) amongst the members who would have been entitled thereto, if distributed by way of dividend and in the same proportions.

(ii) The sum aforesaid shall not be paid in cash but shall be applied, subject to the provision contained in clause (iii), either in or towards—

- A. paying up any amounts for the time being unpaid on any shares held by such members respectively;
- B. paying up in full, unissued shares of the company to be allotted and distributed, credited as fully paid-up, to and amongst such members in the proportions aforesaid;
- C. partly in the way specified in sub-clause (A) and partly in that specified in sub-clause (B);

(iii) A securities premium account and a capital redemption reserve account may, for the purposes of this regulation, be applied in the paying up of unissued shares to be issued to members of the company as fully paid bonus shares;

(iv) The Board shall give effect to the resolution passed by the company in pursuance of this regulation.

43. (i) Whenever such a resolution as aforesaid shall have been passed, the Board shall—

- (a) make all appropriations and applications of the undivided profits resolved to be capitalised thereby, and all allotments and issues of fully paid shares if any; and
- (b) generally do all acts and things required to give effect thereto.

(ii) The Board shall have power—

- (a) to make such provisions, by the issue of fractional certificates or by payment in cash or otherwise as it thinks fit, for the case of shares becoming distributable in fractions; and
- (b) to authorise any person to enter, on behalf of all the members entitled thereto, into an agreement with the company providing for the allotment to them respectively, credited as fully paid-up, of any further shares to which they may be entitled upon such capitalisation, or as the case may require, for the payment by the company on their behalf, by the application thereto of their respective proportions of profits resolved to be capitalised, of the amount or any part of the amounts remaining unpaid on their existing shares;

(iii) Any agreement made under such authority shall be effective and binding on such members.

#### **Dematerialisation Of Securities**

44. (i) **For the purpose of this Article:-**

**"Beneficial Owner"**: Beneficial Owner shall have the meaning assigned thereto in section 2(1)(a) of the Depositories Act, 1996.

**"Depositories Act"**: Depositories Act shall mean the Depositories Act, 1996 and includes any statutory modification or re-enactment thereof for the time being in force.

**"Depository"**: Depository shall mean a Depository as defined in section 2(1)(e) of the Depositories Act, 1996.

**"Member"**: Member shall mean a duly registered holder from time to time of the security of the company and includes every person whose name is entered as beneficial owner in the records of the Depository.

**"Security"**: Security shall mean such security as may be specified by SEBI.

(ii) **"Dematerialisation of Securities"**: Notwithstanding anything on the contrary contained in this Article, the company shall be entitled to dematerialise its securities and to offer securities in a dematerialised form and further to rematerialise the securities held on depository pursuant to the Depositories Act, 1996 or any amendment thereof.

(iii) **"Option to hold securities in physical form or with depository"**: Every person holding securities of the company through allotment or otherwise shall have the option to receive and hold the same in the dematerialised form with a depository.

(iv) **"Beneficial Owner may opt out of a Depository"**: Every person holding securities of the company with a depository, being the beneficial owner thereof, may at any time opt out of the depository in the manner provided under the provisions of the Depositories Act and the Rules, if any, prescribed there under and on fulfilment of the conditions prescribed by the company from time to time, company shall issue the relevant security certificates to the beneficial owner thereof.

(v) **"Securities in Depositories to be in fungible form"**: All securities held by a depository shall be dematerialised and shall be in fungible form. Nothing contained in Sections 153, 153A, 153B,



187B, 187C and 372A of the Companies Act, shall apply to a depository in respect of the securities held by it on behalf of the beneficial owners.

- (vi) **"Rights of depository and beneficial owners"**: A depository shall be deemed to be the registered owner for the purposes of affecting the transfer of ownership of securities on behalf of the beneficial owners and shall not have any voting rights or any other rights in respect of the securities held by it.
- (vii) Every person holding securities of the Company and whose name is entered as the beneficial owner in the records of the depository shall be deemed to be a member of the Company. The beneficial owner of securities shall be entitled to all rights and benefits and be subject to all the liabilities in respect of his/her securities, which are held by a depository.
- (viii) **"Transfer of securities"**: Transfer of security held in a depository will be governed by the provisions of the Depository Act, 1996. Nothing contained in Section 56 of the Companies Act, 2013 or these Articles shall apply to a transfer of securities effected by a transferor and transferee both of whom are entered as beneficial owners in the records of a depository.
- (ix) **"Register and Index of beneficial owners"**: The Register and Index of beneficial owners maintained by a depository under the Depositories Act, 1996 shall be deemed to be the Register and Index of Members and Security holders for the purpose of these Articles.
- (x) **"Other matters"**: Notwithstanding anything contained in these Articles, the provision of Depositories Act, 1996 relating to dematerialisation of securities including any modification(s) or re-enactment thereof and Rules/Regulations made there under shall prevail accordingly.
- (xi) Notwithstanding anything contained in the Act or the Articles, where securities are held in a depository, the records of the beneficial ownership may be served by such depository on the company by means of electronic mode or by delivery of floppies or disks.

#### *Nomination*

45. Notwithstanding anything contained in Articles, every holder of shares(s) or debenture(s) of the Company may, at any time, nominate, in the prescribed manner, a person to whom these share(s) shall vest in the event of his death and the provisions of Section 109A and Section 109B of the Companies Act, 1956 shall apply in respect of such nomination.

The provisions of this Article shall apply mutatis mutandis to a depository of money with the Company as per the provisions of Section 58A of the Act.

#### *Buy-Back Of Shares*

46. Notwithstanding anything contained in these articles but subject to the provisions of sections 68 to 70 and any other applicable provision of the Act or any other law for the time being in force, the company may purchase its own shares or other specified securities.

#### *General Meetings*

47. All general meetings other than Annual General Meeting shall be called extraordinary general meeting.
48. (i) The Board may, whenever it thinks fit, call an extraordinary general meeting.
- (ii) If at any time directors capable of acting who are sufficient in number to form a quorum are not within India, any director or any two members of the company may call an extraordinary general meeting in the same manner, as nearly as possible, as that in which such a meeting may be called by the Board.

#### *Proceedings At General Meetings*

49. (i) No business shall be transacted at any general meeting unless a quorum of members is present at the time when the meeting proceeds to business.
- (ii) Save as otherwise provided herein, the quorum for the general meetings shall be as provided in section 103.

- (iii) The chairperson, if any, of the Board shall preside as Chairperson at every general meeting of the company.
- (iv) If there is no such Chairperson, or if he is not present within fifteen minutes after the time appointed for holding the meeting, or is unwilling to act as chairperson of the meeting, the directors present shall elect one of their members to be Chairperson of the meeting.
- (v) If at any meeting no director is willing to act as Chairperson or if no director is present within fifteen minutes after the time appointed for holding the meeting, the members present shall choose one of their members to be Chairperson of the meeting.

#### ***Adjournment Of Meeting***

50. (i) The Chairperson may, with the consent of any meeting at which a quorum is present, and shall, if so directed by the meeting, adjourn the meeting from time to time and from place to place.
- (ii) No business shall be transacted at any adjourned meeting other than the business left unfinished at the meeting from which the adjournment took place.
- (iii) When a meeting is adjourned for thirty days or more, notice of the adjourned meeting shall be given as in the case of an original meeting.
- (iv) Save as aforesaid, and as provided in section 103 of the Act, it shall not be necessary to give any notice of an adjournment or of the business to be transacted at an adjourned meeting.

#### ***Voting Rights***

51. Subject to any rights or restrictions for the time being attached to any class or classes of shares,—
- (a) on a show of hands, every member present in person shall have one vote; and
  - (b) on a poll, the voting rights of members shall be in proportion to his share in the paid-up equity share capital of the company.
52. A member may exercise his vote at a meeting by electronic means in accordance with section 108 and shall vote only once.
53. (i) In the case of joint holders, the vote of the senior who tenders a vote, whether in person or by proxy, shall be accepted to the exclusion of the votes of the other joint holders.
- (ii) For this purpose, seniority shall be determined by the order in which the names stand in the register of members.
54. A member of unsound mind, or in respect of whom an order has been made by any court having jurisdiction in lunacy, may vote, whether on a show of hands or on a poll, by his committee or other legal guardian, and any such committee or guardian may, on a poll, vote by proxy.
55. Any business other than that upon which a poll has been demanded may be proceeded with, pending the taking of the poll.
56. No member shall be entitled to vote at any general meeting unless all calls or other sums presently payable by him in respect of shares in the company have been paid.
57. (i) No objection shall be raised to the qualification of any voter except at the meeting or adjourned meeting at which the vote objected to is given or tendered, and every vote not disallowed at such meeting shall be valid for all purposes.
- (ii) Any such objection made in due time shall be referred to the Chairperson of the meeting, whose decision shall be final and conclusive.

#### ***Proxy***

58. The instrument appointing a proxy and the power-of-attorney or other authority, if any, under which it is signed or a notarised copy of that power or authority, shall be deposited at the registered office of the company not less than 48 hours before the time for holding the meeting or adjourned meeting at which the person

named in the instrument proposes to vote, or, in the case of a poll, not less than 24 hours before the time appointed for the taking of the poll; and in default the instrument of proxy shall not be treated as valid.

59. An instrument appointing a proxy shall be in the form as prescribed in the rules made under section 105.
60. A vote given in accordance with the terms of an instrument of proxy shall be valid, notwithstanding the previous death or insanity of the principal or the revocation of the proxy or of the authority under which the proxy was executed, or the transfer of the shares in respect of which the proxy is given:

Provided that no intimation in writing of such death, insanity, revocation or transfer shall have been received by the company at its office before the commencement of the meeting or adjourned meeting at which the proxy is used.

#### ***Board Of Directors***

61. Until otherwise determined by a General Meeting of the Company and subject to the provisions of Section 149 of the Act, 2013 the number of Directors (including Debenture and Alternate Directors) shall not be less than three and not more than fifteen. Provided that a company may appoint more than fifteen directors after passing a special resolution.

62. The First Directors of the Company are:

1. Umesh V. Katti
2. Babu A. Dhammangi
3. G.B. Patil

63. (i) Subject to the provisions of the Act, the Company may pay any remuneration, as determined by the Board of Directors / General Meeting to all or any of its Directors for the services rendered by them / him in day to day management of the affairs of the company or any other type of services, whether professional in nature or not, for any of the purposes of the company, either by a fixed sum on monthly or annual basis and / or perquisites and / or a percentage of the profits or otherwise as may be determined by the Board or the members in General Meeting.

The remuneration of the directors shall, in so far as it consists of a monthly payment, be deemed to accrue from day-to-day.

- (ii) In addition to the remuneration payable to them in pursuance of the Act, the directors may be paid all travelling, hotel and other expenses properly incurred by them—

(a) in attending and returning from meetings of the Board of Directors or any committee thereof or general meetings of the company; or

(b) in connection with the business of the company.

64. The Board may pay all expenses incurred in getting up and registering the company.
65. The company may exercise the powers conferred on it by section 88 with regard to the keeping of a foreign register; and the Board may (subject to the provisions of that section) make and vary such regulations as it may think fit respecting the keeping of any such register.
66. All cheques, promissory notes, drafts, hundis, bills of exchange and other negotiable instruments, and all receipts for monies paid to the company, shall be signed, drawn, accepted, endorsed, or otherwise executed, as the case may be, by such person and in such manner as the Board shall from time to time by resolution determine.
67. Every director present at any meeting of the Board or of a committee thereof shall sign his name in a book to be kept for that purpose.
68. (i) Subject to the provisions of section 149, the Board shall have power at any time, and from time to time, to appoint a person as an additional director, provided the number of the directors and additional directors together shall not at any time exceed the maximum strength fixed for the Board by the articles.

(ii) Such person shall hold office only up to the date of the next annual general meeting of the company but shall be eligible for appointment by the company as a director at that meeting subject to the provisions of the Act.

#### *Proceedings of the Board*

69. (i) The Board of Directors may meet for the conduct of business, adjourn and otherwise regulate its meetings, as it thinks fit.
- (ii) Subject to the Articles herein, a director may, and the manager or secretary on the requisition of a director shall, at any time, summon a meeting of the Board.
- (iii) Save as otherwise expressly provided in the Act, questions arising at any meeting of the Board shall be decided by a majority of votes.
- (iv) In case of an equality of votes, the Chairperson of the Board, if any, shall have a second or casting vote.
70. The continuing directors may act notwithstanding any vacancy in the Board; but, if and so long as their number is reduced below the quorum fixed by the Act for a meeting of the Board, the continuing directors or director may act for the purpose of increasing the number of directors to that fixed for the quorum, or of summoning a general meeting of the company, but for no other purpose.
71. (i) The Board may elect a Chairperson of its meetings and determine the period for which he is to hold office.
- (ii) If no such Chairperson is elected, or if at any meeting the Chairperson is not present within five minutes after the time appointed for holding the meeting, the directors present may choose one of their number to be Chairperson of the meeting.
72. (i) The Board may, subject to the provisions of the Act, delegate any of its powers to committees consisting of such member or members of its body as it thinks fit.
73. (ii) Any committee so formed shall, in the exercise of the powers so delegated, conform to any regulations that may be imposed on it by the Board.
74. A committee may elect a Chairperson of its meetings.
75. If no such Chairperson is elected, or if at any meeting the Chairperson is not present within five minutes after the time appointed for holding the meeting, the members present may choose one of their members to be Chairperson of the meeting.
76. (i) A committee may meet and adjourn as it thinks fit.
- (ii) Questions arising at any meeting of a committee shall be determined by a majority of votes of the members present, and in case of an equality of votes, the Chairperson shall have a second or casting vote.
77. All acts done in any meeting of the Board or of a committee thereof or by any person acting as a director, shall, notwithstanding that it may be afterwards discovered that there was some defect in the appointment of any one or more of such directors or of any person acting as aforesaid, or that they or any of them were disqualified, be as valid as if every such director or such person had been duly appointed and was qualified to be a director.
78. Save as otherwise expressly provided in the Act, a resolution in writing, signed by all the members of the Board or of a committee thereof, for the time being entitled to receive notice of a meeting of the Board or committee, shall be valid and effective as if it had been passed at a meeting of the Board or committee, duly convened and held.

---

***Chief Executive Officer, Manager, Company Secretary or Chief Financial Officer***

79. Subject to the provisions of the Act,—
- (i) A chief executive officer, manager, company secretary or chief financial officer may be appointed by the Board for such term, at such remuneration and upon such conditions as it may think fit; and any chief executive officer, manager, company secretary or chief financial officer so appointed may be removed by means of a resolution of the Board;
- (ii) A director may be appointed as chief executive officer, manager, company secretary or chief financial officer.
80. A provision of the Act or these regulations requiring or authorising a thing to be done by or to a director and chief executive officer, manager, company secretary or chief financial officer shall not be satisfied by its being done by or to the same person acting both as director and as, or in place of, chief executive officer, manager, company secretary or chief financial officer.

***Managing Director***

80. The business of the Company may be carried on by the Managing Director(s) who may be appointed by the Board of Directors / members in their General Meeting, from time to time who shall fix the terms, qualifications, remuneration, duties, authorities and powers. The Board may from time to time and subject to the provisions of the Act delegate to the Managing Director(s) such of their powers and duties and subject to such limitations and conditions as they may deem fit. The Board may from time to time, revoke, withdraw, alter or vary all or any of the powers conferred on him or dismiss him from office and appoint another in his place.
81. Subject to the provisions of section 179 and 180 of the Companies Act, 2013, the Managing Director of the Company, if any, shall be empowered to carry on the day to day business affairs of the Company. He shall have the general control, management and superintendence of the business of the Company with power to appoint and to dismiss employees and to enter into contracts on behalf of the Company in the ordinary course of business and to do and perform all other acts, deeds and things which in the ordinary course of business may be considered necessary/proper or in the interest of the Company.

***The Seal***

82. (i) The Board shall provide for the safe custody of the seal.
- (ii) The seal of the company shall not be affixed to any instrument except by the authority of a resolution of the Board or of a committee of the Board authorised by it in that behalf, and except in the presence of at least two directors and of the secretary or such other person as the Board may appoint for the purpose; and those two directors and the secretary or other person aforesaid shall sign every instrument to which the seal of the company is so affixed in their presence.

***Dividends And Reserve***

83. The company in general meeting may declare dividends, but no dividend shall exceed the amount recommended by the Board.
84. Subject to the provisions of section 123, the Board may from time to time pay to the members such interim dividends as appear to it to be justified by the profits of the company.
85. (i) The Board may, before recommending any dividend, set aside out of the profits of the company such sums as it thinks fit as a reserve or reserves which shall, at the discretion of the Board, be applicable for any purpose to which the profits of the company may be properly applied, including provision for meeting contingencies or for equalizing dividends; and pending such application, may, at the like discretion, either be employed in the business of the company or be invested in such investments (other than shares of the company) as the Board may, from time to time, think fit.
- (ii) The Board may also carry forward any profits which it may consider necessary not to divide, without setting them aside as a reserve.

(i) Subject to the rights of persons, if any, entitled to shares with special rights as to dividends, all dividends shall be declared and paid according to the amounts paid or credited as paid on the shares in respect whereof the dividend is paid, but if and so long as nothing is paid upon any of the shares in the company, dividends may be declared and paid according to the amounts of the shares.

(ii) No amount paid or credited as paid on a share in advance of calls shall be treated for the purposes of this regulation as paid on the share.

(iii) All dividends shall be apportioned and paid proportionately to the amounts paid or credited as paid on the shares during any portion or portions of the period in respect of which the dividend is paid; but if any share is issued on terms providing that it shall rank for dividend as from a particular date such share shall rank for dividend accordingly.

86. The Board may deduct from any dividend payable to any member all sums of money, if any, presently payable by him to the company on account of calls or otherwise in relation to the shares of the company.

87. (i) Any dividend, interest or other monies payable in cash in respect of shares may be paid by cheque or warrant sent through the post directed to the registered address of the holder or, in the case of joint holders, to the registered address of that one of the joint holders who is first named on the register of members, or to such person and to such address as the holder or joint holders may in writing direct.

(ii) Every such cheque or warrant shall be made payable to the order of the person to whom it is sent

88. Any one of two or more joint holders of a share may give effective receipts for any dividends, bonuses or other monies payable in respect of such share.

89. Notice of any dividend that may have been declared shall be given to the persons entitled to share therein in the manner mentioned in the Act.

90. No dividend shall bear interest against the company.

91. No unclaimed Dividend shall be forfeited before the claim becomes barred by law, and unclaimed Dividends shall be dealt with in accordance with the applicable provisions of the Act

#### *Accounts*

92. (i) The Board shall from time to time determine whether and to what extent and at what times and places and under what conditions or regulations, the accounts and books of the company, or any of them, shall be open to the inspection of members not being directors.

(ii) No member (not being a director) shall have any right of inspecting any account or book or document of the company except as conferred by law or authorised by the Board or by the company in general meeting.

#### *Winding Up*

93. If the company shall be wound up, the liquidator may, with the sanction of a special resolution of the company and any other sanction required by the Act, divide amongst the members, in specie or kind, the whole or any part of the assets of the company, whether they shall consist of property of the same kind or not.

94. For the purpose aforesaid, the liquidator may set such value as he deems fair upon any property to be divided as aforesaid and may determine how such division shall be carried out as between the members or different classes of members.

95. The liquidator may, with the like sanction, vest the whole or any part of such assets in trustees upon such trusts for the benefit of the contributories if he considers necessary, but so that no member shall be compelled to accept any shares or other securities whereon there is any liability.



---

**INDEMNITY**

96. Every officer of the company shall be indemnified out of the assets of the company against any liability incurred by him in defending any proceedings, whether civil or criminal, in which judgment is given in his favour or in which he is acquitted or in which relief is granted to him by the court or the Tribunal.

*The erstwhile Articles of Association, containing Article 1 – 229 was replaced by new set of Articles of Association containing Article 1 to 97 vide a resolution passed in the EGM held on 18<sup>th</sup> December, 2017.*

## SECTION XI – OTHER INFORMATION

### MATERIAL CONTRACTS AND DOCUMENTS FOR INSPECTION

The copies of the following contracts which have been entered or are to be entered into by our Company (not being contracts entered into in the ordinary course of business carried on by our Company or contracts entered into more than two years before the date of this Red Herring Prospectus) which are or may be deemed material will be attached to the copy of the Red Herring Prospectus which will be delivered to RoC for registration. Copies of these contracts and also the documents for inspection referred to hereunder, may be inspected at the Registered Office between 10.00 a.m. and 5.00 p.m. on all Working Days from the date of the Red Herring Prospectus until the Bid/Offer Closing Date.

#### **A. Material Contracts**

1. Memorandum of Understanding dated December 18, 2017 entered into between our Company, the Selling Shareholders and the Book Running Lead Manager.
2. Memorandum of Understanding dated November 27, 2017 entered into between our Company, the Selling Shareholders and the Registrar to the Offer.
3. Tripartite Agreement dated April 23, 2019 between CDSL, our Company and the Registrar to the Offer.
4. Tripartite Agreement dated December 28, 2017 between NSDL, our Company and the Registrar to the Offer.
5. Escrow Agreement dated September 11, 2019 between our Company, the Selling Shareholders, the Book Running Lead Manager, the Syndicate Members, the Escrow Collection Bank(s), Refund Bank(s) and the Registrar to the Offer.
6. Share Escrow Agreement dated August 26, 2019 between the Selling Shareholders, our Company, the Book Running Lead Manager and the Share Escrow Agent.
7. Syndicate Agreement dated August 26, 2019 between our Company, the Selling Shareholders, the Book Running Lead Manager, and the Syndicate Members and Registrar to the Offer.
8. Underwriting Agreement dated [●] between our Company, the Selling Shareholders, the BRLM and the Underwriters.

#### **B. Material Documents**

1. Certified true copies of the Memorandum and Articles of Association of our Company, as amended from time to time.
2. Certificates of Incorporation as amended from time to time and Certificate of Commencement of Business.
3. Resolution of the Board of Directors dated November 20, 2017 authorising the Offer.
4. Shareholders' Resolution passed at the Extra-ordinary General Meeting of the Company held on December 18, 2017, authorising the Offer
5. Consent Letters from the Selling Shareholders' authorising the Offer.
6. Report of our Statutory Auditor dated July 08, 2019 regarding the Restated Financial Statements of our Company for Fiscal Year ended 2015, 2016, 2017, 2018 and 2019 included in this Red Herring Prospectus.
7. Statement of Tax Benefits dated July 08, 2019 issued by our Statutory Auditor.
8. Consents of our Directors, Chief Financial Officer, Company Secretary and Compliance Officer, BRLM, Legal Counsel to the Offer, Statutory Auditors, Registrar to the Offer, Share Escrow Agent, Bankers to the Offer, Bankers to our Company, Underwriters<sup>(1)</sup> and Syndicate Members as referred to in their specific capacities.

*(1) The aforesaid will be appointed prior to filing of the Prospectus with RoC and their consents as above would be obtained prior to the filing of the Prospectus with RoC.*

9. Due diligence Certificate dated December 20, 2017 addressed to SEBI issued by the BRLM.
10. Resolution of the Board of Directors of our Company dated December 20, 2017, approving the Draft Red Herring Prospectus and Resolution of the Board of Directors of our Company dated September 16, 2019, approving this Red Herring Prospectus.
11. Certificates dated July 08, 2019 each issued by our Statutory Auditors i.e. M/s. Gojanur & Co., Chartered Accountants certifying the working capital requirements for the F. Y. 2019-20 and certifying the Internal Accruals as on March 31, 2019.
12. Copy of Memorandum of Understanding dated August 16, 2017 and September 26, 2017 between our Company and Venture Capital and Corporate Investments Private Limited for the purpose of acting as Exit Offer Registrars for the Exit Offer – 1 and Exit Offer – 2 respectively.
13. Copy of Agreement dated August 23, 2017 and September 25, 2017 between our Company and Yes Bank Limited for the purpose of acting as Exit Offer Escrow Bankers for the Exit Offer – 1 and Exit Offer – 2 respectively.
14. Copy of Appointment Letter dated August 07, 2017 confirming M/s. S. P. Ghali & Co., Company Secretaries to act as Independent Company Secretary for verification of the eligible shareholders for for the Exit Offers.
15. Copy of Appointment Letter dated August 08, 2017 confirming NSVR & Associates LLP, Chartered Accountants to act as Independent Chartered Accountant for confirmation of the process and outcome of the Exit Offers.
16. Copy of Certificates dated August 16, 2017 and September 29, 2017 issued by M/s. S. P. Ghali & Co., Company Secretaries certifying the eligible shareholders for the Exit Offer – 1 and Exit Offer – 2.
17. Copy of Certificates dated November 20, 2017 each issued by M/s. NSRV & Associates, Chartered Accountants certifying the compliance in the Exit Offer – 1 and Exit Offer – 2 pursuant to SEBI Circular CIR/CFD/DIL3/18/2015 dated December 31, 2015.
18. Copy of Trust Deed dated May 21, 2010 for the VSL Shareholders Welfare Trust
19. In – principle listing approvals dated January 12, 2018 and January 10, 2018 from BSE and NSE, respectively.
20. SEBI observation letter no. SRO/Issues/AT/ 0004467/01/2019 dated February 15, 2019.

Any of the contracts or documents mentioned in this Red Herring Prospectus may be amended or modified at any time if so required in the interest of our Company or if required by the other parties, without reference to the shareholders subject to compliance of the provisions contained in the Companies Act and other relevant statutes.

## DECLARATION

We hereby declare that all relevant provisions of the Companies Act, 1956, the Companies Act, 2013 and the guidelines/regulations issued by the Government of India or the guidelines/regulations issued by the Securities and Exchange Board of India, established under section 3 of the Securities and Exchange Board of India Act, 1992, as the case may be, have been complied with and no statement made in this Red Herring Prospectus is contrary to the provisions of the Companies Act, 1956, the Companies Act, 2013, the Securities Contract (Regulation) Act, 1956, the Securities and Exchange Board of India Act, 1992 or rules made or guidelines or regulations issued there under, as the case may be. We further certify that all statements in this Red Herring Prospectus are true and correct.

## Signed by the Directors of our Company

  
**Umesh Katti**  
 Chairman & Non-Executive Director

  
**Nishil Katti**  
 Managing Director

  
**Mukesh Kumar**  
 Whole-time Director (Additional Director)

  
**Lata Katti**  
 Whole-time Director

  
**Kush Katti**  
 Whole-time Director

  
**Surender Chot**  
 Non-Executive Independent Director

  
**Shivakund Tubachi**  
 Non-Executive Independent Director

  
**Basavaraj Hugaragi**  
 Non-Executive Independent Director

  
**Praibha Munnoli**  
 Non-Executive Independent Director

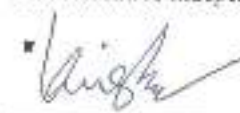
  
**R. V. Rudhkrishna**  
 Non-Executive Independent Director

## Signed by the Chief Financial Officer of our Company

  
**Sheshagiri Kulkarni**  
 (Chief Financial Officer)

## Signed by the Company Secretary and Compliance Officer of our Company

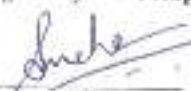
  
**Sneha Patil**  
 (Company Secretary and Compliance Officer)

Date: September 16, 2019  
 Place: Bellad Bagewadi

**DECLARATION BY SELLING SHAREHOLDERS**

Each Selling Shareholder, severally and not jointly, certifies that all statements and undertakings made in this Red Herring Prospectus by it or in relation to itself and the Equity Shares being offered by it by way of the Offer are true and correct. Each Selling Shareholder assumes no responsibility for any other statements in this Red Herring Prospectus.

**Signed on behalf of the Selling Shareholders by its duly constituted attorney holder**



**Mr. Nikhil Katti (as the duly constituted power of attorney holder for the Selling Shareholders)**

Date: September 16, 2019

Place: Bellad Bagewadi

**ANNEXURE A – LIST OF SELLING SHAREHOLDERS**

Sr. No.	Name of Shareholder	Pre-Offer		Offered Shares		Post- Offer	
		Number of equity shares	As a % of Pre-offer share capital	Number of equity shares Offered	As a % of Total number of shares offered	Number of equity shares	As a % of Post-offer share capital
<b>Promoters</b>							
1	Nikhil Katti	36,92,875	10.69%	2,00,000	2.86%	34,92,875	9.30%
2	Lava Katti	12,00,275	3.47%	1,00,000	1.43%	11,00,275	2.93%
3	Kush Katti	12,45,075	3.60%	1,00,000	1.43%	11,45,075	3.05%
<b>Promoter Group</b>							
4	Rammappa Khemalpure	537,000	1.55%	5,37,000	7.67%	0	0.00%
5	Ashok Utture	1,029,300	2.98%	10,29,300	14.70%	0	0.00%
6	Kashinath Utture	681,000	1.97%	6,81,000	9.73%	0	0.00%
7	Kadayya Pujar	643,550	1.86%	6,43,550	9.19%	0	0.00%
8	Basavaraj Pujar	639,600	1.85%	6,39,600	9.14%	0	0.00%
9	Ramesh Shiralakar	500,650	1.45%	4,98,350	7.11%	2,300	0.01%
10	Sudhir Katti	400,700	1.16%	4,00,700	5.72%	0	0.00%
11	Ramappa Bani	340,850	0.99%	3,40,850	4.87%	0	0.00%
12	Muragesh Katti	321,500	0.93%	3,21,500	4.59%	0	0.00%
13	Kallapa Bani	297,500	0.86%	2,97,500	4.25%	0	0.00%
14	Rajaram Shiralkar	263,400	0.76%	2,63,400	3.76%	0	0.00%
15	Gurappa Katti	165,850	0.48%	1,65,850	2.37%	0	0.00%
16	Vinod Katti	157,550	0.46%	1,57,550	2.25%	0	0.00%
17	Purnima Pangi	5,000	0.01%	5,000	0.07%	0	0.00%
18	Padmaja Katti	10,000	0.03%	5,000	0.07%	5,000	0.01%
19	Sanjay Khemalpure	4,900	0.01%	4,900	0.07%	0	0.00%
20	Sudharshan Khemalpure	1,500	0.00%	1,500	0.02%	0	0.00%
21	Pallavi Ghuli	1,000	0.00%	1,000	0.01%	0	0.00%
22	Tejasvini Chunamuri	1,000	0.00%	1,000	0.01%	0	0.00%
23	Yuvaraj Chunamuri	2,000	0.01%	1,000	0.01%	1,000	0.00%
24	Prachi Ghuli	1,000	0.00%	1,000	0.01%	0	0.00%
25	Satish Ghuli	2,000	0.01%	1,000	0.01%	1,000	0.00%
26	Suhas Ghuli	2,000	0.00%	1,000	0.01%	1,000	0.00%
27	Channavva Chunamuri	1,000	0.00%	1,000	0.01%	0	0.00%
28	Shanmukappa Chunamuri	1,000	0.00%	1,000	0.01%	0	0.00%
29	Drakashayani Katti	3,500	0.01%	3,500	0.05%	0	0.00%
30	Kalavati Savadakar	1,000	0.00%	1,000	0.01%	0	0.00%
31	Shailaja Uchale	1,000	0.00%	1,000	0.01%	0	0.00%
<b>Public</b>							
32	Riyaz Bargeer	789,100	2.28%	5,56,950	7.96%	232,150	0.62%
33	Shridevi Angadi	6,500	0.02%	6,500	0.09%	0	0.00%
34	Pallavi Hawanale	6,500	0.02%	6,500	0.09%	0	0.00%
35	Rekha Katti	6,000	0.02%	6,000	0.09%	0	0.00%
36	Sandeep Katti	6,000	0.02%	6,000	0.09%	0	0.00%
37	Nirmala Lingadalli	3,500	0.01%	3,500	0.05%	0	0.00%
38	Mahadevi Bellad	3,500	0.01%	3,500	0.05%	0	0.00%
39	Lalita Khemalpure	3,000	0.01%	3,000	0.04%	0	0.00%
40	Mohan Munnoli	2,000	0.01%	2,000	0.03%	0	0.00%
	<b>TOTAL</b>	<b>1,29,80,675</b>	<b>37.56%</b>	<b>70,00,000</b>	<b>100.00%</b>	<b>59,80,675</b>	<b>15.92%</b>